



Document Title	M121GNX2 R1 Product Information			Page No.	1/31
Document No.		Issue date	2013/11/25	Revision	03

Product Information

To:

Product Name: M121GNX2 R1

Document Issue Date: 2013/11/25

Customer	InfoVision Optoelectronics
<u>SIGNATURE</u>	<u>SIGNATURE</u>
_____	REVIEWED BY QA
_____	_____
_____	PREPARED BY FAE
_____	_____
Please return 1 copy for your confirmation with your signature and comments.	

- Note: 1. Please contact InfoVision Company before designing your product based on this product.
2. The information contained herein is presented merely to indicate the characteristics and performance of our products. No responsibility is assumed by IVO for any intellectual property claims or other problems that may result from application based on the module described herein.

FQ-7-30-0-009-03C



Document Title	M121GNX2 R1 Product Information			Page No.	2/31
Document No.		Issue date	2013/11/25	Revision	03

Revision	Date	Page	Old Description	New Description	Remark
00	2013/09/18	all	--	First issue.	
01	2013/09/24	19	No Interface Timings min	Add Interface Timings min	
02	2013/11/25	17	Only 8 bit data mapping	Add 6 bit data mapping	
03	2014/05/15	4	Only 8 bit support color	Add 6bit support color	
		8	Only RT Total, no Tr、Tf	Define Tr、Tf	
		12	No FPWM	Add FPWM	

IVO Confidential document



Document Title	M121GNX2 R1 Product Information			Page No.	3/31
Document No.		Issue date	2013/11/25	Revision	03

Contents

1.0	General Descriptions	4
2.0	Absolute Maximum Ratings	6
3.0	Pixel Format Image.....	7
4.0	Optical Characteristics	8
5.0	Backlight Characteristics.....	12
6.0	Electrical Characteristics.....	14
7.0	Interface Timings	20
8.0	Power Consumption.....	22
9.0	Power ON/OFF Sequence	23
10.0	Mechanical Characteristics	24
11.0	Package Specification.....	27
12.0	Reliability Conditions.....	28
13.0	Lot Mark.....	29
14.0	General Precaution.....	30

Document Title	M121GNX2 R1 Product Information			Page No.	4/31
Document No.		Issue date	2013/11/25	Revision	03

1.0 General Descriptions

1.1 Introduction

The M121GNX2 R1 is a color active matrix thin film transistor (TFT) liquid crystal display (LCD) that uses amorphous silicon TFT as a switching device. It is composed of a TFT LCD panel, a backlight system, column driver and row driver circuit. This TFT LCD has a 12.1-inch diagonally measured active display area with XGA resolution (1024 horizontal by 768 vertical) pixels arrays.

1.2 Features

- 12.1" TFT LCD Panel
- LED Backlight System
- Supported XGA 1024x768 pixels resolution
- Compatible with RoHS standard

1.3 Product Summary

Items	Specifications	Unit
Screen Diagonal	12.1	Inch
Active Area	245.76 (H) x184.32 (V)	mm
Pixels H x V	1024(RGB) x768	-
Pixel Pitch	0.24(H)x0.24 (V)	mm
Pixel Arrangement	R.G.B. Vertical Stripe	-
Display Mode	Normally White	-
White Luminance	350 (TYP)	cd /m ²
Contrast Ratio	800 (TYP)	-
Response Time	16 (TYP)	msec
Input Voltage	3.3	V
Power Consumption	6.925 (Max)	W
Weight	545 (Max)	g
Outline Dimension	279.0(H) ×209.0(V) ×9.0(D)	mm
Electrical Interface (Logic)	LVDS	-
Support Color	262K/16.7M	-
Optimum Viewing Direction	6 o'clock	-
Surface Treatment	Anti-glare & hardness 3H	-

Document Title	M121GNX2 R1 Product Information			Page No.	5/31
Document No.		Issue date	2013/11/25	Revision	03

1.4 Functional Block Diagram

Figure 1 shows the functional block diagram of the LCD module.

Figure 1 Block Diagram

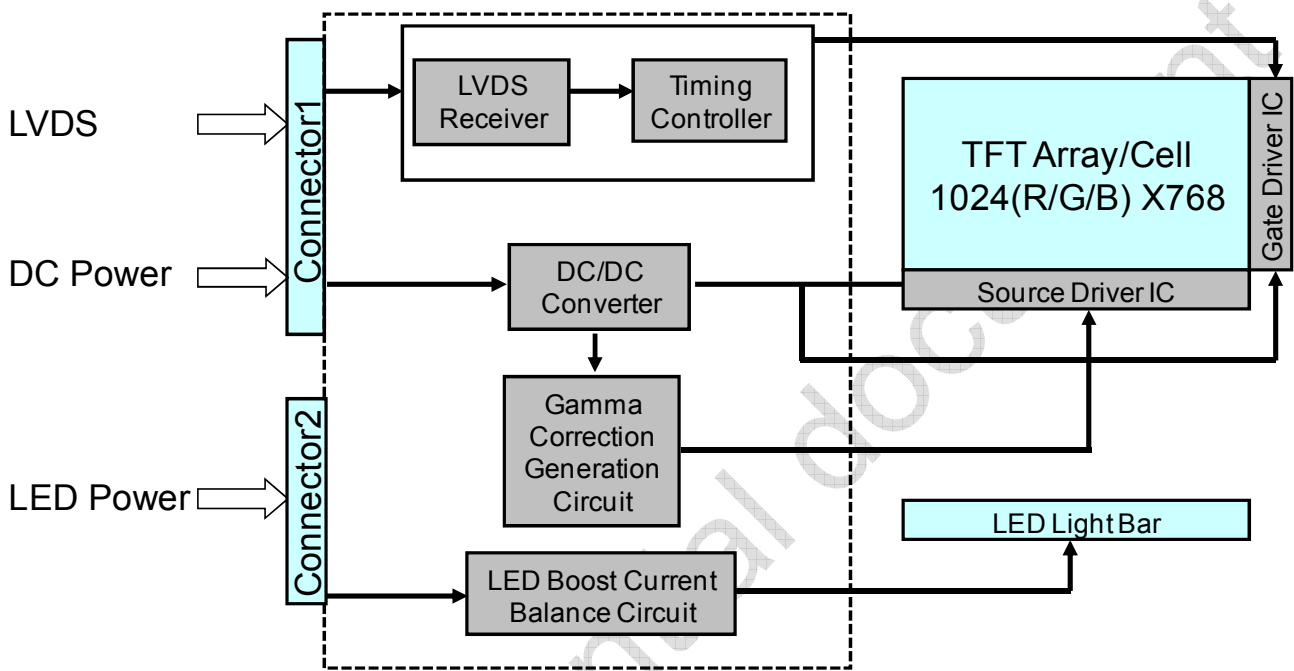

Document Title	M121GNX2 R1 Product Information			Page No.	6/31
Document No.		Issue date	2013/11/25	Revision	03

2.0 Absolute Maximum Ratings

Table 1 Absolute Ratings of Environment

Item	Symbol	Min.	Max.	Unit	Conditions
Supply Voltage	V _{DD}	-0.5	5	V	(1)
Operating Temperature	T _{OP}	-20	70	°C	(1) (2) (3) (4)
Operating Humidity	H _{OP}	10	85	%RH	-
Storage Temperature	T _{ST}	-30	80	°C	-
Storage Humidity	H _{ST}	10	95	%RH	-

Note (1): Humidity: 85%RH Max. (T<=40°C) Note static electricity.

Maximum wet bulb temperature at 39°C or less. (T>40°C) No condensation.

Note (2): There is a possibility of causing deterioration in the irregularity and others of the screen and the display fineness though the liquid crystal module doesn't arrive at destruction when using it at 80~85°C or -20°C.

Note (3): There is a possibility of causing the fineness deterioration by the prolonged use in the (high temperature) humidity environment (60% or more).

Note (4): In the operating temperature item, the low temperature side is the ambient temperature regulations. The high temperature side is the panel surface temperature regulations.

Note (5): Storage Range&Operating Range Picture:

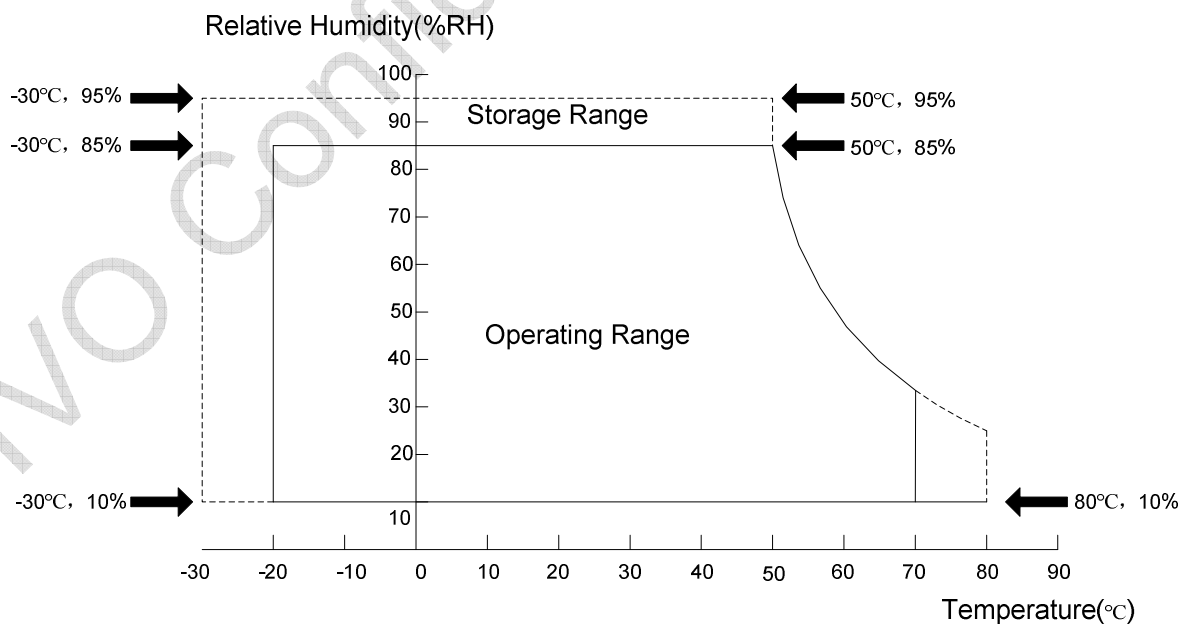

Document Title	M121GNX2 R1 Product Information			Page No.	7/31
Document No.		Issue date	2013/11/25	Revision	03

3.0 Pixel Format Image

Figure 1 shows the relationship of the input signals and LCD pixel format image.

Figure 2 Pixel Format

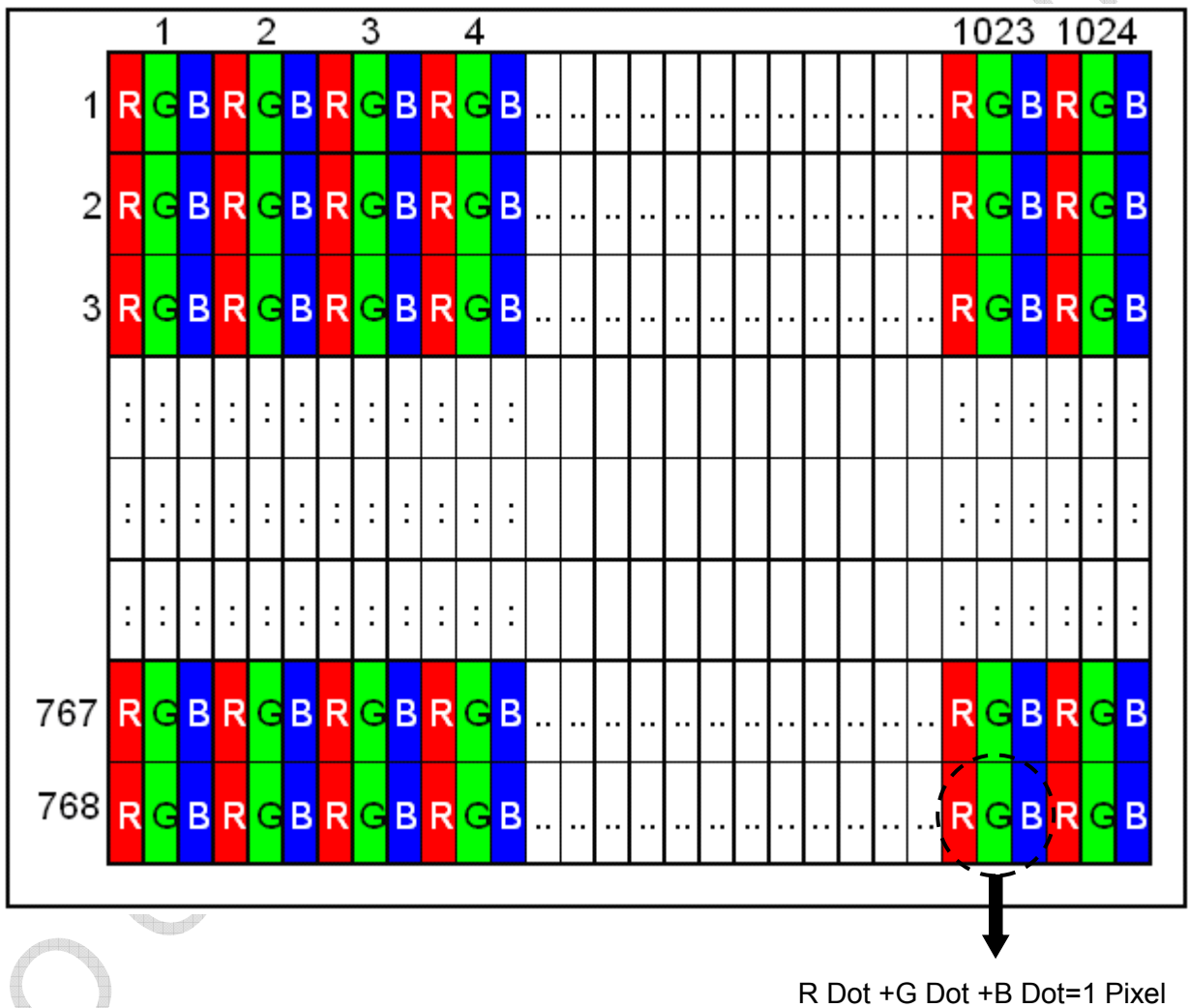

Document Title	M121GNX2 R1 Product Information			Page No.	8/31
Document No.		Issue date	2013/11/25	Revision	03

4.0 Optical Characteristics

The optical characteristics are measured under stable conditions as following notes

Table 2 Optical Characteristics

Item	Conditions	Min.	Typ.	Max.	Unit	Note
Viewing Angle (CR>10)	Horizontal	θ_{x+}	70	80	-	degree (1),(2),(3)
		θ_{x-}	70	80	-	
	Vertical	θ_{y+}	70	80	-	
		θ_{y-}	70	80	-	
Contrast Ratio	Center	720	800	-	-	(1),(2),(4)
Response Time	Rising (90%→10%)	-	4	5.2	ms	(1),(2),(5)
	Falling (10%→90%)	-	12	15.6		
	Rising + Falling	-	16	20.8		
Color Chromaticity (CIE1931)	White x	0.255	0.305	0.355	-	(1),(2)
	White y	0.275	0.325	0.375	-	
	Red x	0.614	0.644	0.674	-	
	Red y	0.314	0.344	0.374	-	
	Green x	0.280	0.310	0.340	-	
	Green y	0.604	0.634	0.664	-	
	Blue x	0.122	0.152	0.182	-	
	Blue y	0.051	0.081	0.111	-	
NTSC		-	72	-	-	
White Luminance	5 Points Average	315	350	-	cd/m ²	(1),(2),(6)
Luminance Uniformity	9 Points	75	80	-	%	(1),(2),(7)

Document Title	M121GNX2 R1 Product Information			Page No.	9/31
Document No.		Issue date	2013/11/25	Revision	03

Note (1) Measurement Setup:

The LCD module should be stabilized at given temperature(25°C) for 15 minutes to Avoid abrupt temperature change during measuring. In order to stabilize the luminance, the measurement should be executed after lighting backlight for 15 minutes in a windless room.

Figure 3 Measurement Setup

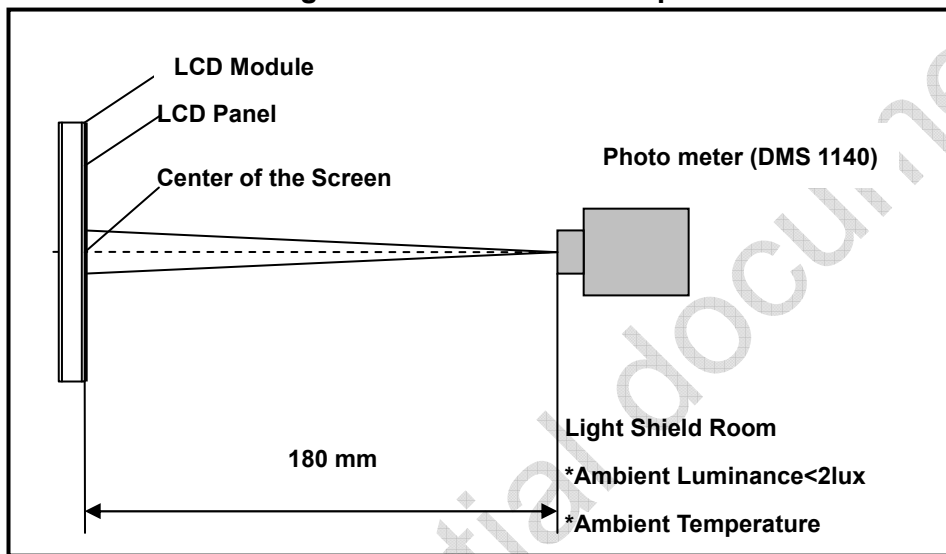

Note (2) The LED input parameter setting as: I_LED: 240mA

V_LED: 12V

PWM_LED: Duty 100%

Note (3) Definition of Viewing Angle

Figure 5 Definition of Viewing Angle

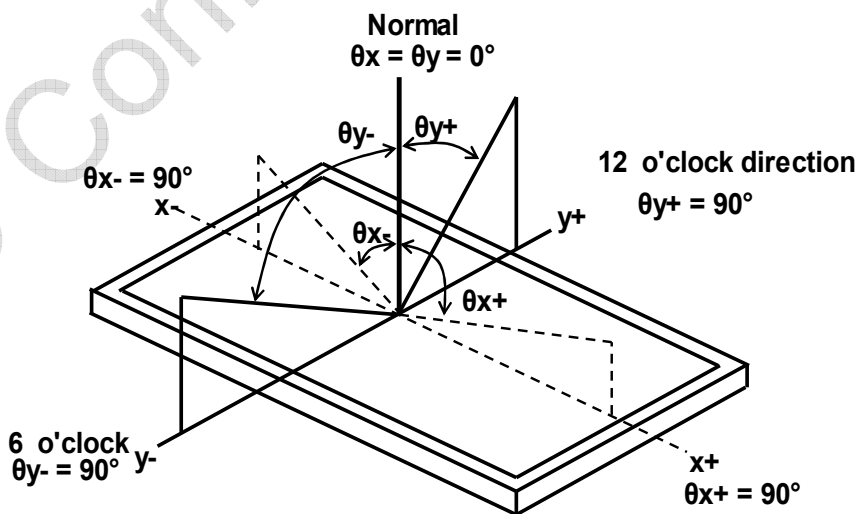

Document Title	M121GNX2 R1 Product Information			Page No.	10/31
Document No.		Issue date	2013/11/25	Revision	03

Note (4) Definition Of Contrast Ratio (CR)

The contrast ratio can be calculated by the following expression

$$\text{Contrast Ratio (CR)} = L_{255} / L_0$$

L255: Luminance of gray level L255, L0: Luminance of gray level 0

Note (5) Definition Of Response Time (T_R , T_F)

Figure 4 Definition of Response Time

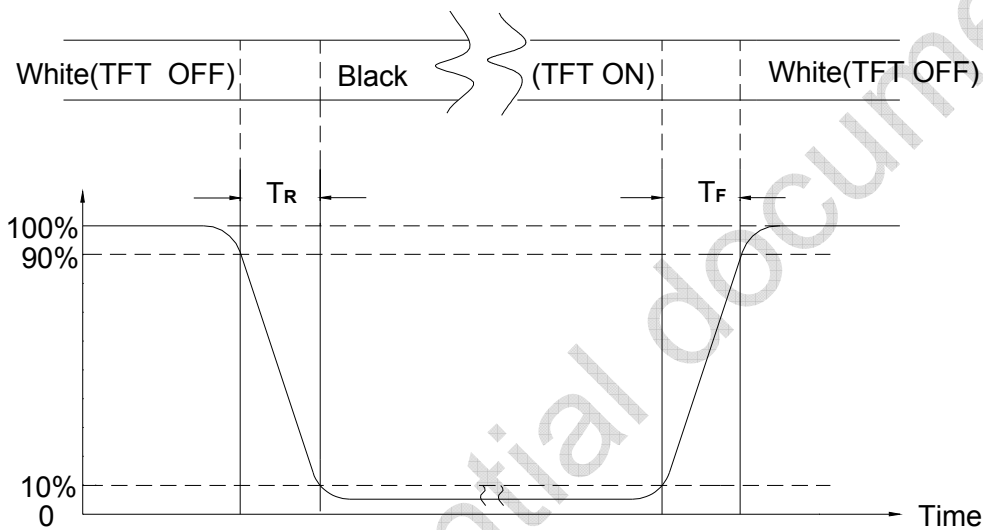

Note (6) Definition Of Luminance White

Measure the luminance of gray level L255 at center point (Ref.: Active Area)

$$\text{Display Luminance} = (L_1 + L_2 + L_3 + L_4 + L_5) / 5$$

H—Active area length, V—Active area width, L—Luminance

Figure 5 Measurement Locations Of 5 Points

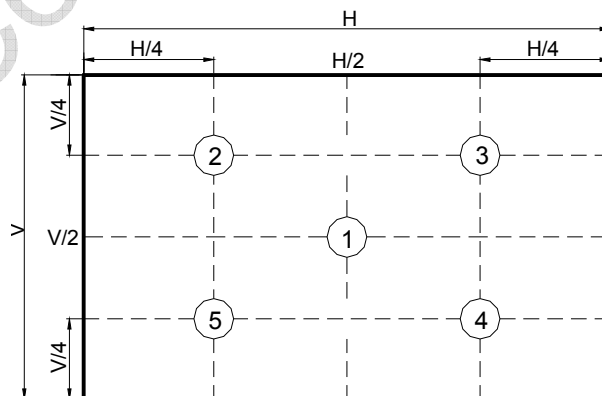

Document Title	M121GNX2 R1 Product Information			Page No.	11/31
Document No.		Issue date	2013/11/25	Revision	03

Note (7) Definition Of Luminance Uniformity (Ref.: Active Area)

Measure the luminance of gray level 255 at 9 points.

$$UNF(9pts) = \frac{\text{Min}(L1, L2, \dots L9)}{\text{Max}(L1, L2, \dots L9)}$$

Figure 6 Measurement Locations of 9 Points

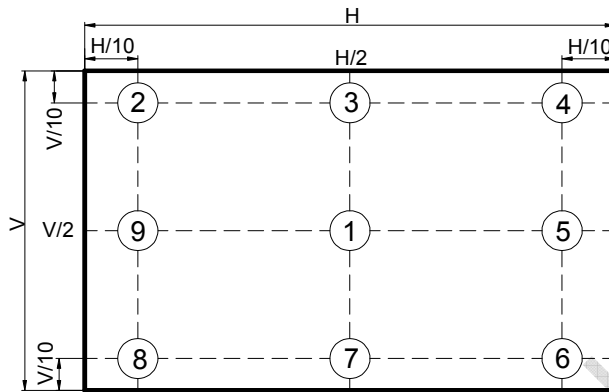

Document Title	M121GNX2 R1 Product Information			Page No.	12/31
Document No.		Issue date	2013/11/25	Revision	03

5.0 Backlight Characteristics

5.1 Parameter Guideline Of LED Backlight

Table 3 Parameter Guideline for LED Backlight

Item	Symbol	Min.	Typ.	Max.	Units	Note	
LED Input Voltage	V _{LED}	10.8	12	12.6	V	(2)	
LED Power Consumption	P _{LED}	-	-	6.1	W	(2)	
LED Forward Voltage	V _F	2.8	3.3	3.6	V	(2)	
LED Forward Current	I _F	-	60	-	mA		
PWM Signal Voltage	V _{PWM_EN}	High	4.5	5	5.5		V
		Low	0	-	0.5		
LED Enable Voltage	V _{LED_EN}	High	2.0	5	5.5		V
		Low	-	0	0.5		
Input PWM Frequency	FPWM	200	-	20,000	Hz		
LED Life Time	LT	30,000	-	-	Hours	(1)(2)	
Duty Ratio	PWM	5	-	100	%	(2)	

Note (1) The LED life time define as the estimated time to 50% degradation of initial luminous.

Note (2) Operating temperature 25°C, humidity 55%RH.



Document Title	M121GNX2 R1 Product Information			Page No.	13/31
Document No.		Issue date	2013/11/25	Revision	03

Table 4 Connector Name / Designation

Item	Description
Input LED	PCB Jack Connector model: MSB24038P5A Manufactured by STM
	PIN IDE Connector model: P24038P5

Table 5 Input LED Signal Pin Assignment

Pin #	Function
1	VCC(12V input)
2	GND
3	On/Off(5V-ON,0V-OFF)
4	Dimming(PWM)
5	NC

Document Title	M121GNX2 R1 Product Information			Page No.	14/31
Document No.		Issue date	2013/11/25	Revision	03

6.0 Electrical Characteristics

6.1 Interface Connector

Table 7 Connector Name / Designation

Item	Description
FPC Down Connector (20pin pitch=1.25mm)	PCB Jack Connector recommended model: MSB240420HE Manufactured by STM
	PIN IDE Connector model: P240420H

Table 8 Signal Pin Assignment

Pin #	Symbol	Description
1	VDD	Power Supply, 3.3V (typical)
2	VDD	Power Supply, 3.3V (typical)
3	VSS	Ground
4	REV	Reverse Scan selection {High:2.5(min), 3.3(typ),3.6(max); Low: 0.5(max)}
5	Rin1-	-LVDS differential data input (R0-R5,G0)
6	Rin1+	+LVDS differential data input (R0-R5,G0)
7	VSS	Ground
8	Rin2-	-LVDS differential data input (G1-G5,B0-B1)
9	Rin2+	+LVDS differential data input (G1-G5,B0-B1)
10	VSS	Ground
11	Rin3-	-LVDS differential data input (B2-B5,HS,VS,DE)
12	Rin3+	+LVDS differential data input (B2-B5,HS,VS,DE)
13	VSS	Ground
14	ClkIN-	-LVDS differential clock input
15	ClkIN+	+LVDS differential clock input
16	GND	Ground
17	Rin4-	-LVDS differential data input (R6-R7,G6-G7,B6-B7)
18	Rin4+	+VDS differential data input (R6-R7,G6-G7,B6-B7)
19	SEL68	6/8 bits LVDS data input selection(H:8bit L/NC:6bit)
20	Bist	Internal use

Note(1) : All input signals shall be low or Hi-resistance state when VDD is off.

Note (2) REV = LOW/NC

Document Title	M121GNX2 R1 Product Information			Page No.	15/31
Document No.		Issue date	2013/11/25	Revision	03

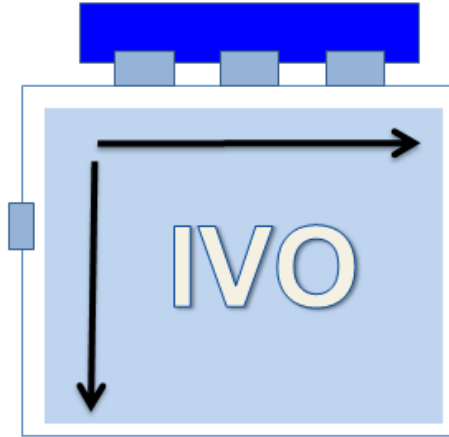

Note (3) REV = High

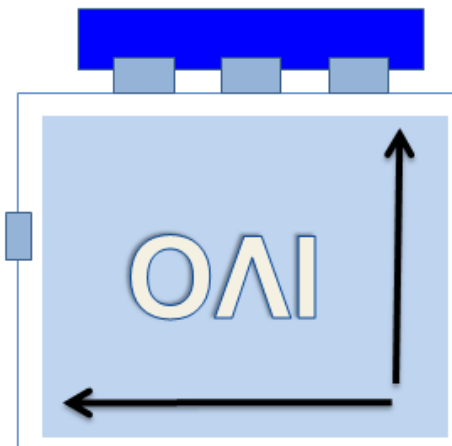

Document Title	M121GNX2 R1 Product Information			Page No.	16/31
Document No.		Issue date	2013/11/25	Revision	03

6.2 LVDS Receiver

6.2.1 Signal Electrical Characteristics For LVDS Receiver

The built-in LVDS receiver is compatible with (ANSI/TIA/TIA-644) standard.

Table 6 LVDS Receiver Electrical Characteristics

Parameter	Symbol	Min.	Typ.	Max.	Unit	Conditions
Differential Input High Threshold	V _{th}	-	-	+100	mV	V _{CM} =+1.2V
Differential Input Low Threshold	V _{tl}	-100	-	-	mV	V _{CM} =+1.2V
Magnitude Differential Input Voltage	V _{ID}	100	-	600	mV	-
Common Mode Voltage	V _{CM}	VID /2+0.6	1.2	1.8- VID /2	V	-
Common Mode Voltage Offset	ΔV _{CM}	-	-	50	mV	V _{CM} =+1.2V

Note: (1) Input signals shall be low or Hi- resistance state when VDD is off.

(2) All electrical characteristics for LVDS signal are defined and shall be measured at the interface connector of LCD.

Figure 9 Voltage Definitions

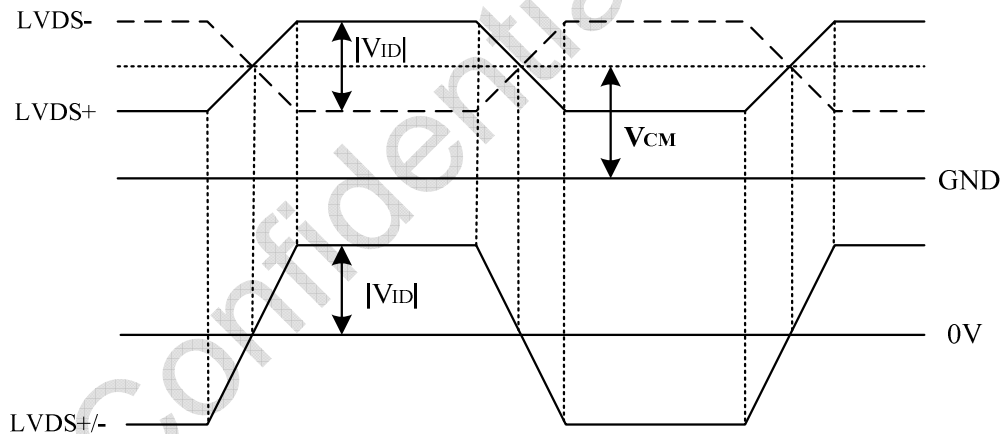

Document Title	M121GNX2 R1 Product Information			Page No.	17/31
Document No.		Issue date	2013/11/25	Revision	03

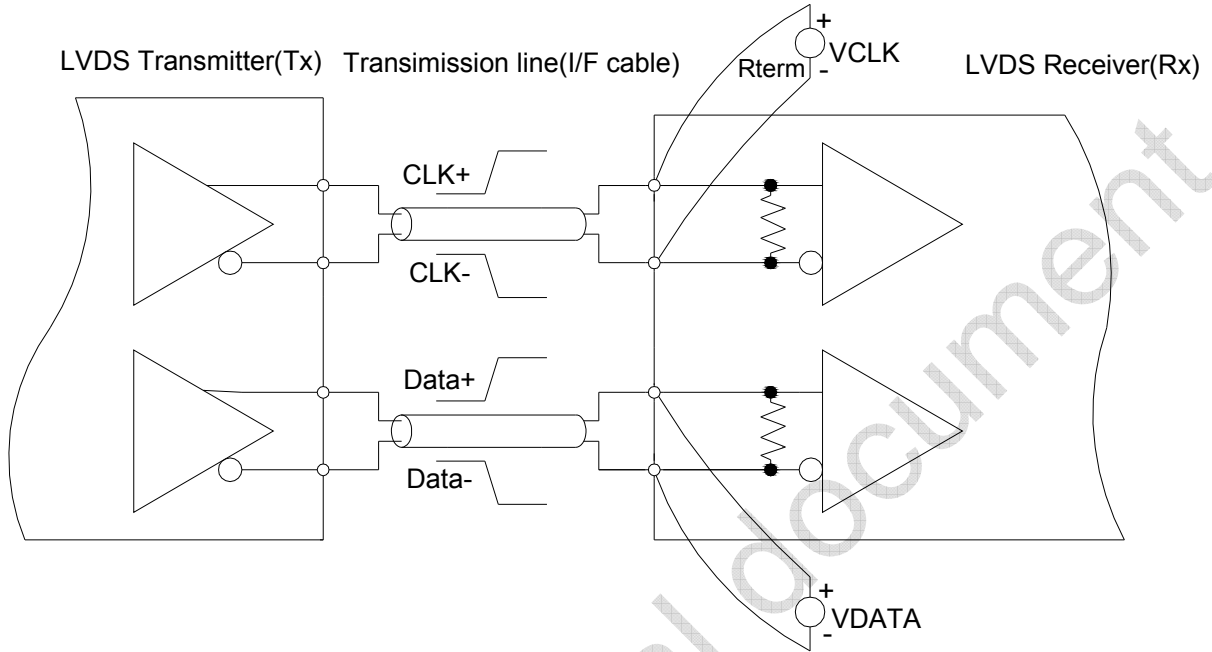
Figure 10 Measurement System

Document Title	M121GNX2 R1 Product Information			Page No.	18/31
Document No.		Issue date	2013/11/25	Revision	03

Figure 11 Date Mapping(8 Bit)

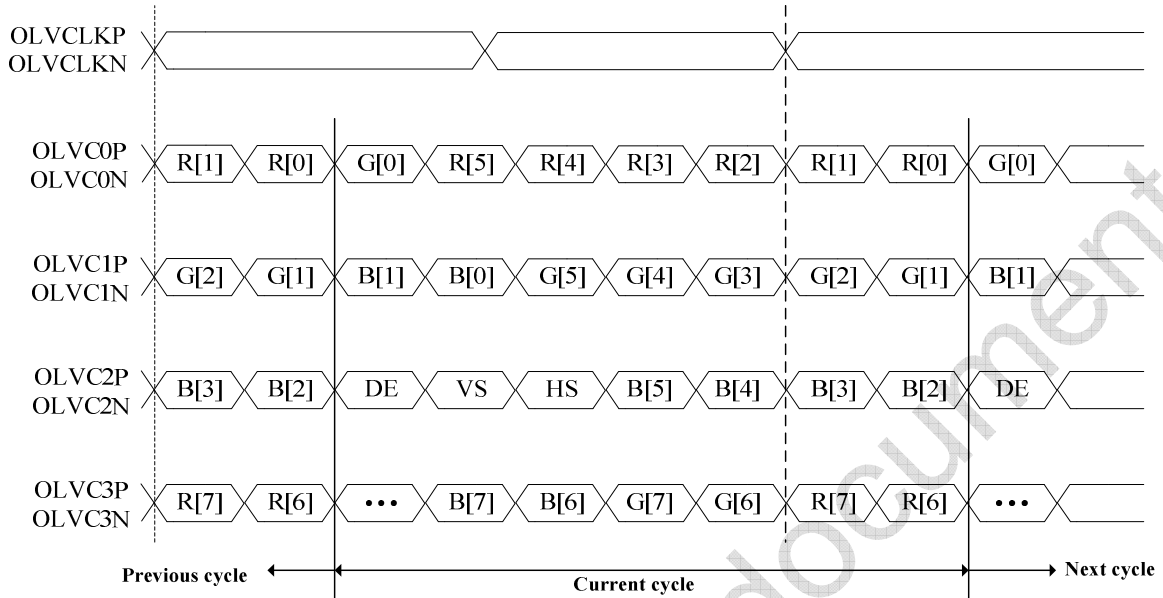
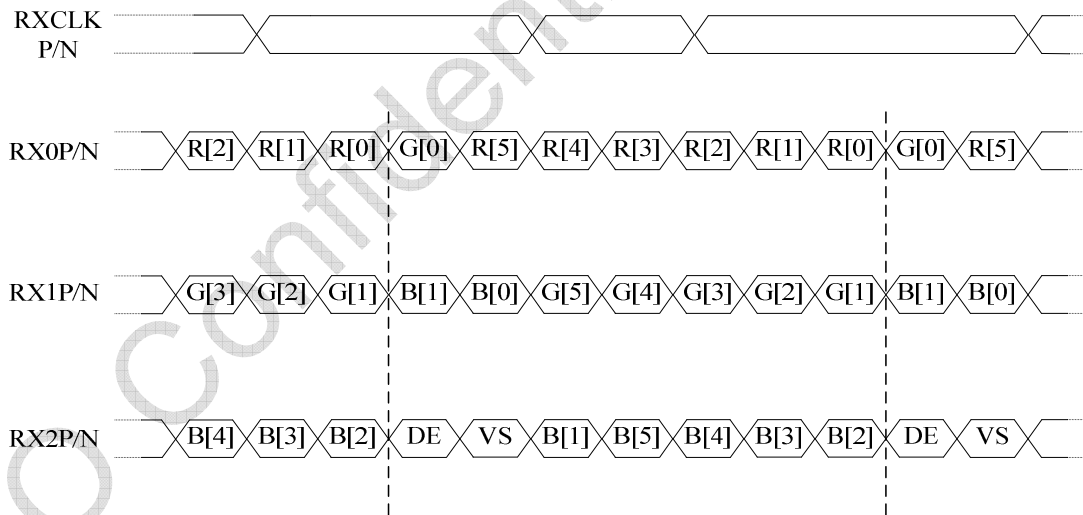

Figure 12 Data Mapping(6 Bit)



Document Title	M121GNX2 R1 Product Information			Page No.	19/31
Document No.		Issue date	2013/11/25	Revision	03

6.2.2 LVDS Receiver Internal Circuit

Figure 13 LVDS Receiver Internal **Circuit** shows the internal block diagram of the LVDS receiver. This LCD module equips termination resistors for LVDS link.

Figure 13 LVDS Receiver Internal Circuit

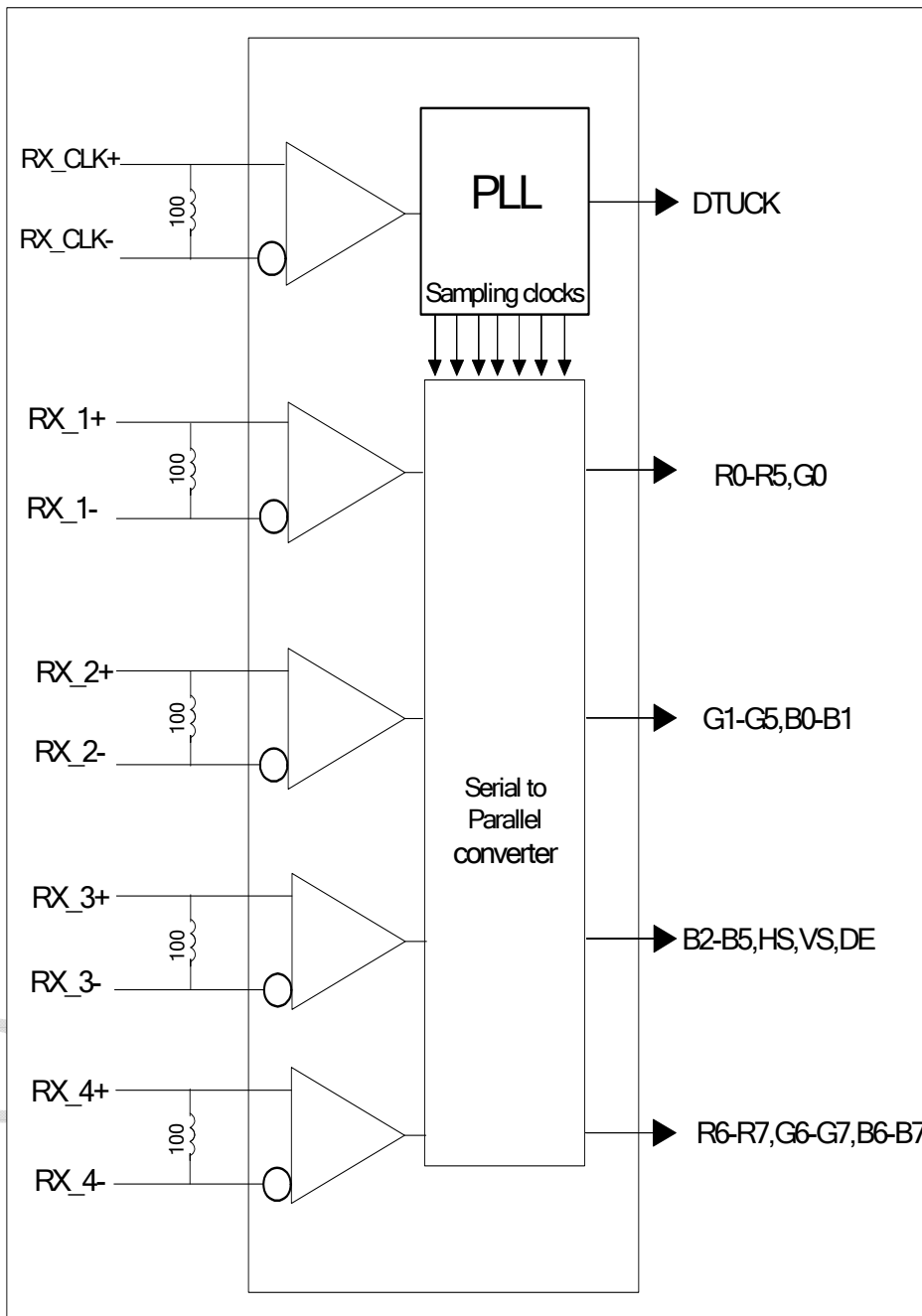

Document Title	M121GNX2 R1 Product Information			Page No.	20/31
Document No.		Issue date	2013/11/25	Revision	03

7.0 Interface Timings

Table 7 Interface Timings

Parameter	Symbol	Unit	Min.	Typ.	Max.
LVDS Clock Frequency	Fclk	MHz	50	65	80
H Total Time	HT	Clocks	1100	1344	2047
H Active Time	HA	Clocks	1024	1024	1024
H Blanking Time	HBL	Clocks	76	320	1023
V Total Time	VT	Lines	776	806	1023
V Active Time	VA	Lines	768	768	768
V Blanking Time	VBL	Lines	8	38	255
Frame Rate	Vsync	Hz	55	60	65

Note: H Blanking Time and V Blanking Time can not be changed at every frame.

Document Title	M121GNX2 R1 Product Information			Page No.	21/31
Document No.		Issue date	2013/11/25	Revision	03

Figure 14 Timing Characteristics

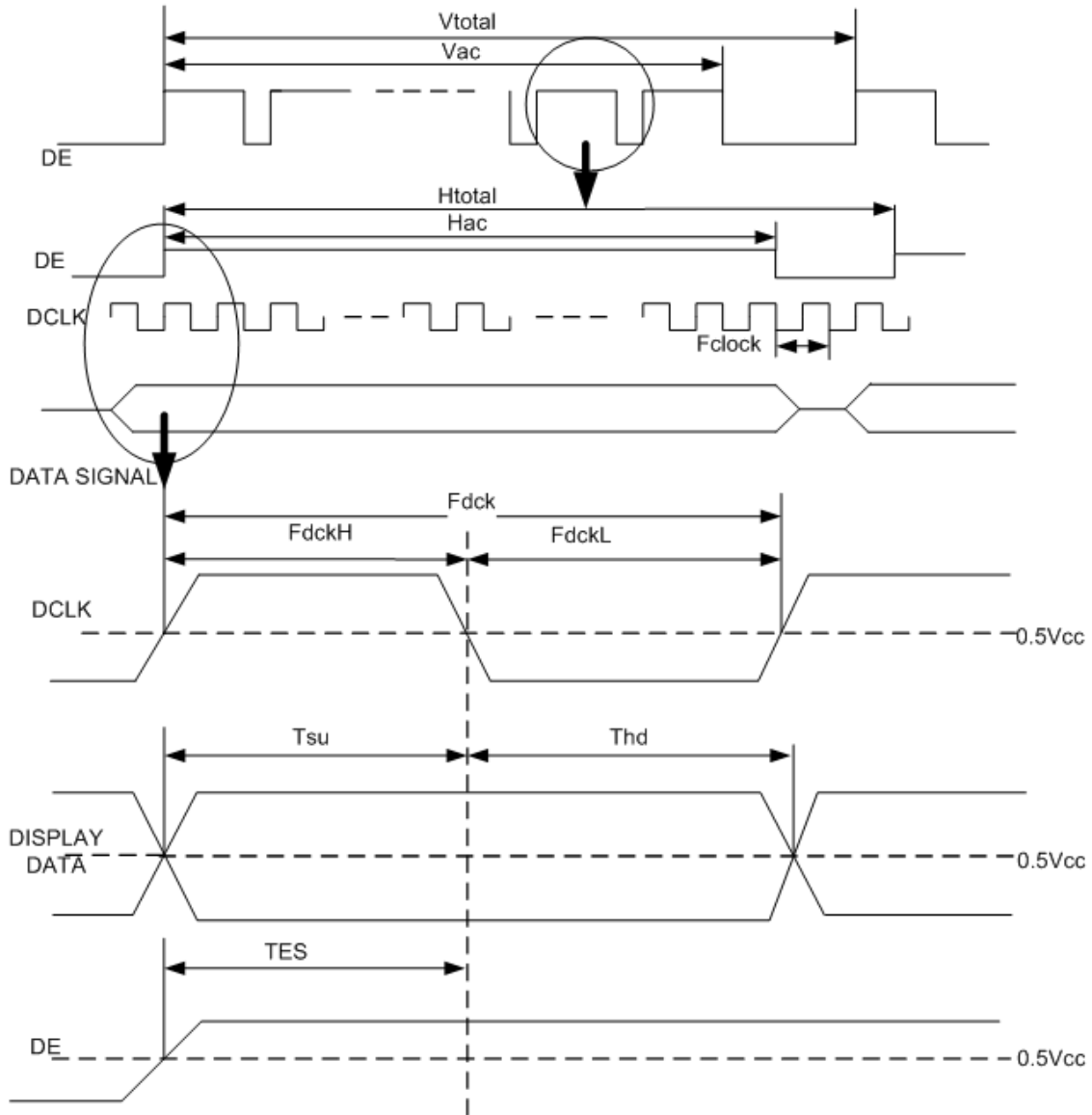

Document Title	M121GNX2 R1 Product Information			Page No.	22/31
Document No.		Issue date	2013/11/25	Revision	03

8.0 Power Consumption

Input power voltage specifications are as follows.

Table 8 Power Voltage

Item	Symbol	Min.	Typ.	Max.	Units	Note	
LCD Drive Voltage (Logic)	VDD	3.0	3.3	3.6	V	(2), (4)	
VDD Current	Black Pattern	IDD	-	-	250	mA	(3),(4),(6)
VDD Power Consumption	Black Pattern	PDD	-	-	0.825	W	
Rush Current	Irush	-	-	3	A	(1),(4),(5)	
Allowable Logic/LCD Drive Ripple Voltage	VDDrp	-	-	200	mV	(4)	

Note (1) Measure Condition

Figure 15 VDD Rising Time

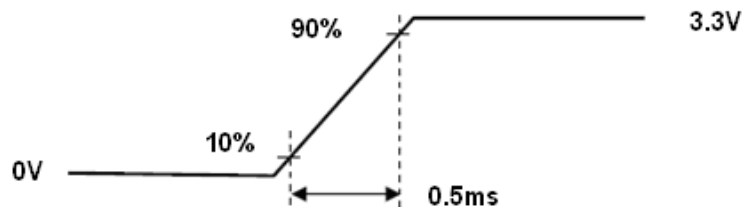

Note (2) VDD Power Dip Condition

If $V_{TH} < V_{DD} \leq V_{min}$, then $t_d \leq 10ms$; When the voltage returns to normal our panel must revive automatically.

Figure 16 VDD Power Dip

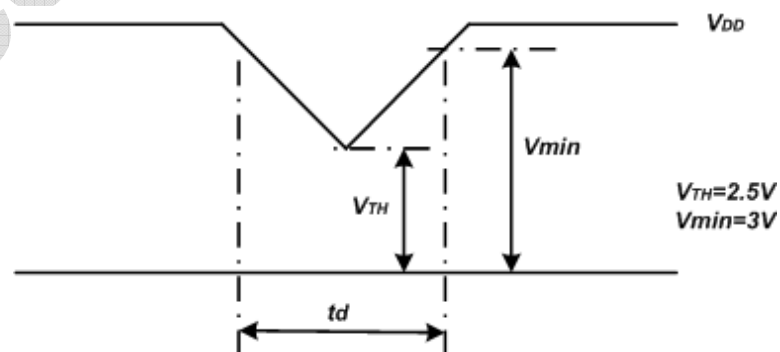

Note (3) Frame Rate=60Hz, VDD=3.3V,DC Current.

Note (4) Operating temperature 25°C, humidity 55%RH.

Document Title	M121GNX2 R1 Product Information			Page No.	23/31
Document No.		Issue date	2013/11/25	Revision	03

9.0 Power ON/OFF Sequence

Power on/off sequence is as follows. Interface signals are also shown in the chart. Signals from any system shall be Hi-resistance state or low level when VDD is off.

Figure 17 Power Sequence

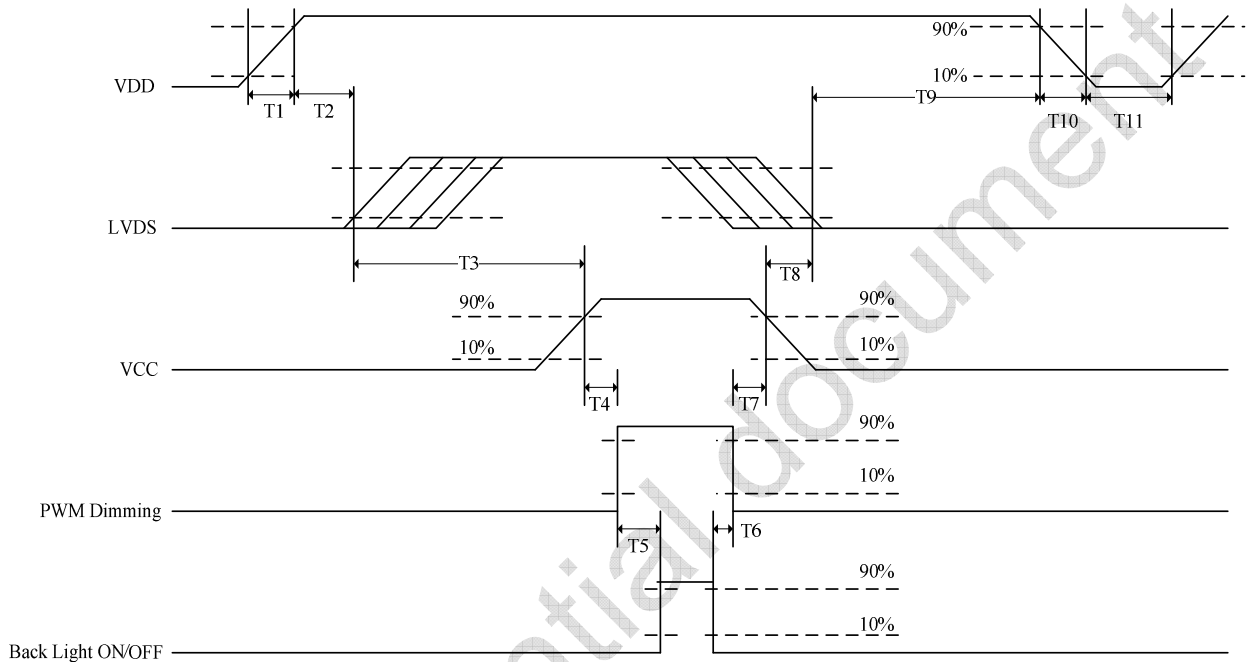

Table 9 Power Sequencing Requirements

Parameter	Unit	min	typ	max
T1	ms	0.5	-	10
T2	ms	30	40	50
T3	ms	200	-	-
T4	ms	10	-	-
T5	ms	10	-	-
T6	ms	0	-	-
T7	ms	10	-	-
T8	ms	100	-	-
T9	ms	0	16	50
T10	ms	-	-	10
T11	ms	1000	-	-

Note (1) Power On Sequence: VCC-> AVDD -> VGL -> VGH -> Data -> B/L

(2) Power Off Sequence: B/L-> Data -> VGH -> VGL -> AVDD -> VCC

Document Title	M121GNX2 R1 Product Information			Page No.	24/31
Document No.		Issue date	2013/11/25	Revision	03

10.0 Mechanical Characteristics

10.1 Outline Drawing

Figure 18 Outline Drawing (Front Side)

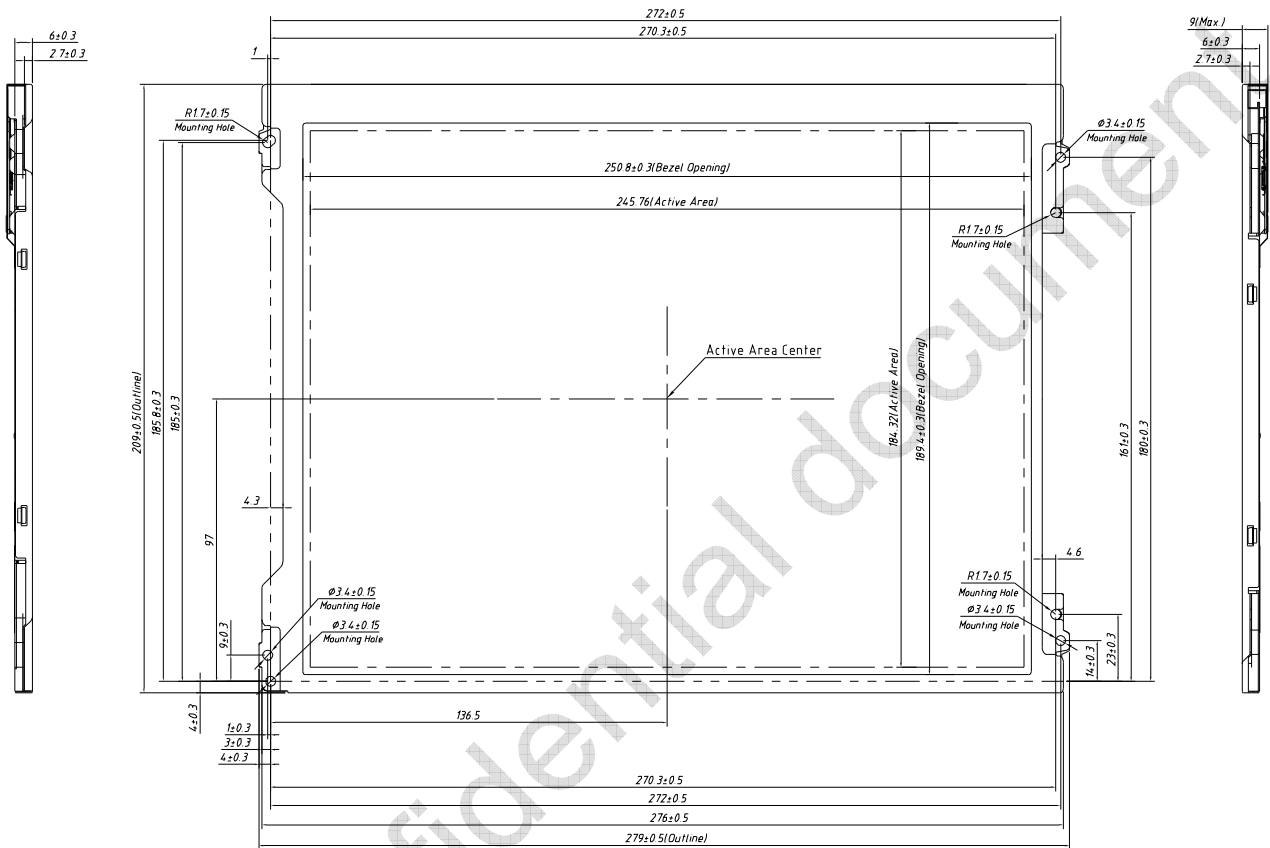



Document Title	M121GNX2 R1 Product Information			Page No.	25/31
Document No.		Issue date	2013/11/25	Revision	03

Figure 19 Outline Drawing (Back Side)

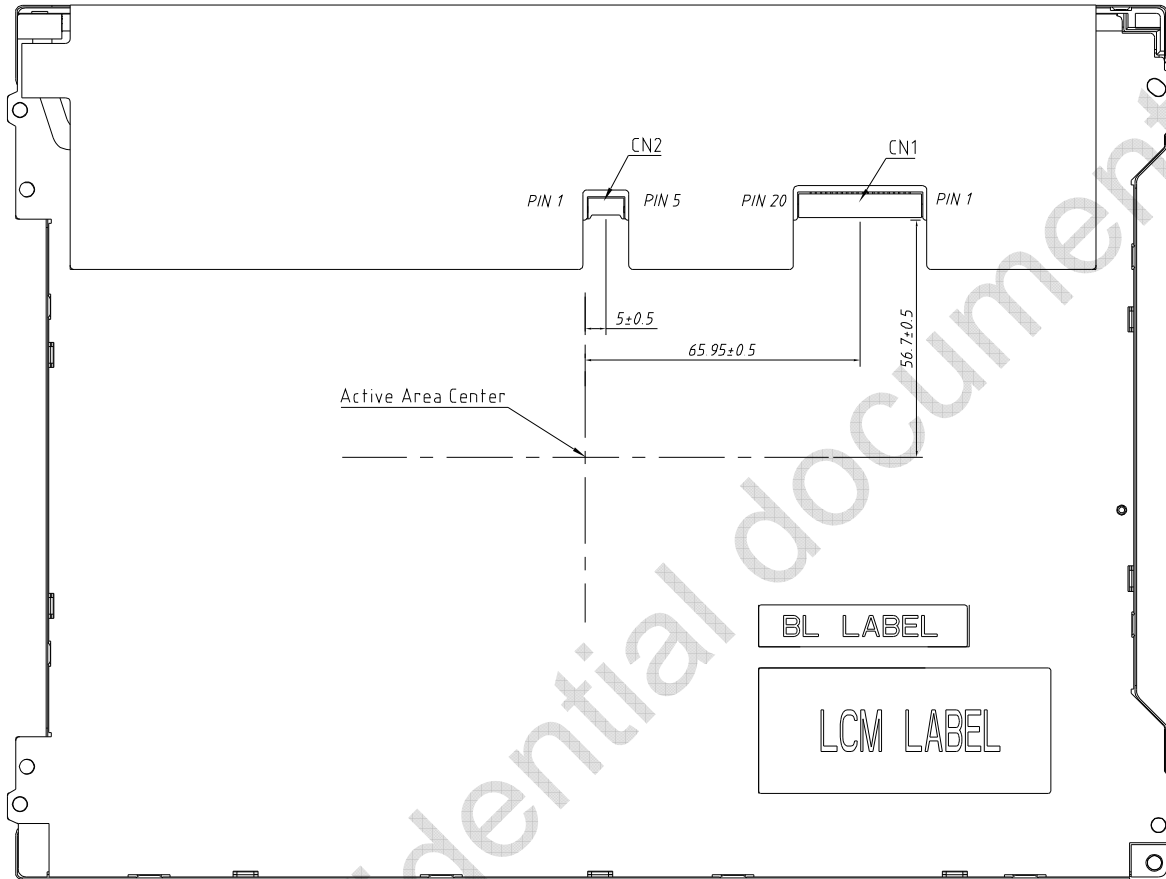

Document Title	M121GNX2 R1 Product Information			Page No.	26/31
Document No.		Issue date	2013/11/25	Revision	03

10.2 Dimension Specifications

Table 10 Module Dimension Specifications

Item	Min.	Typ.	Max.	Units
Width	278.5	279.0	279.5	mm
Height	208.5	209.0	209.5	mm
Thickness	5.7(without PCBA)	6(without PCBA)	6.3(without PCBA)	mm
Weight	-	518.7	545	g
BM : a-b & c-d	≤1.0			mm

Figure 20 BM Area

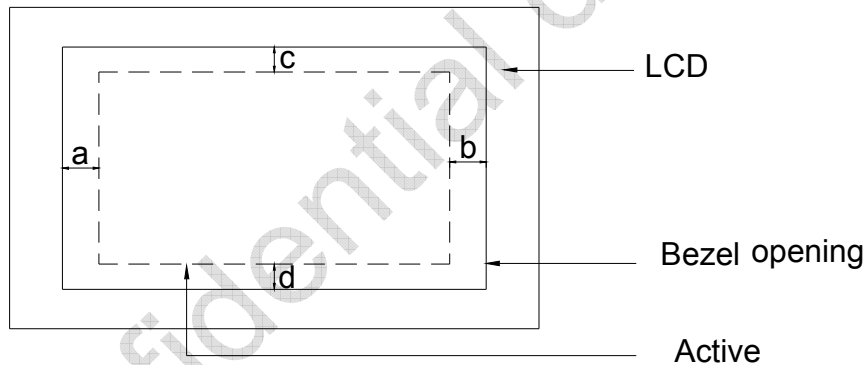

Document Title	M121GNX2 R1 Product Information			Page No.	27/31
Document No.		Issue date	2013/11/25	Revision	03

11.0 Package Specification

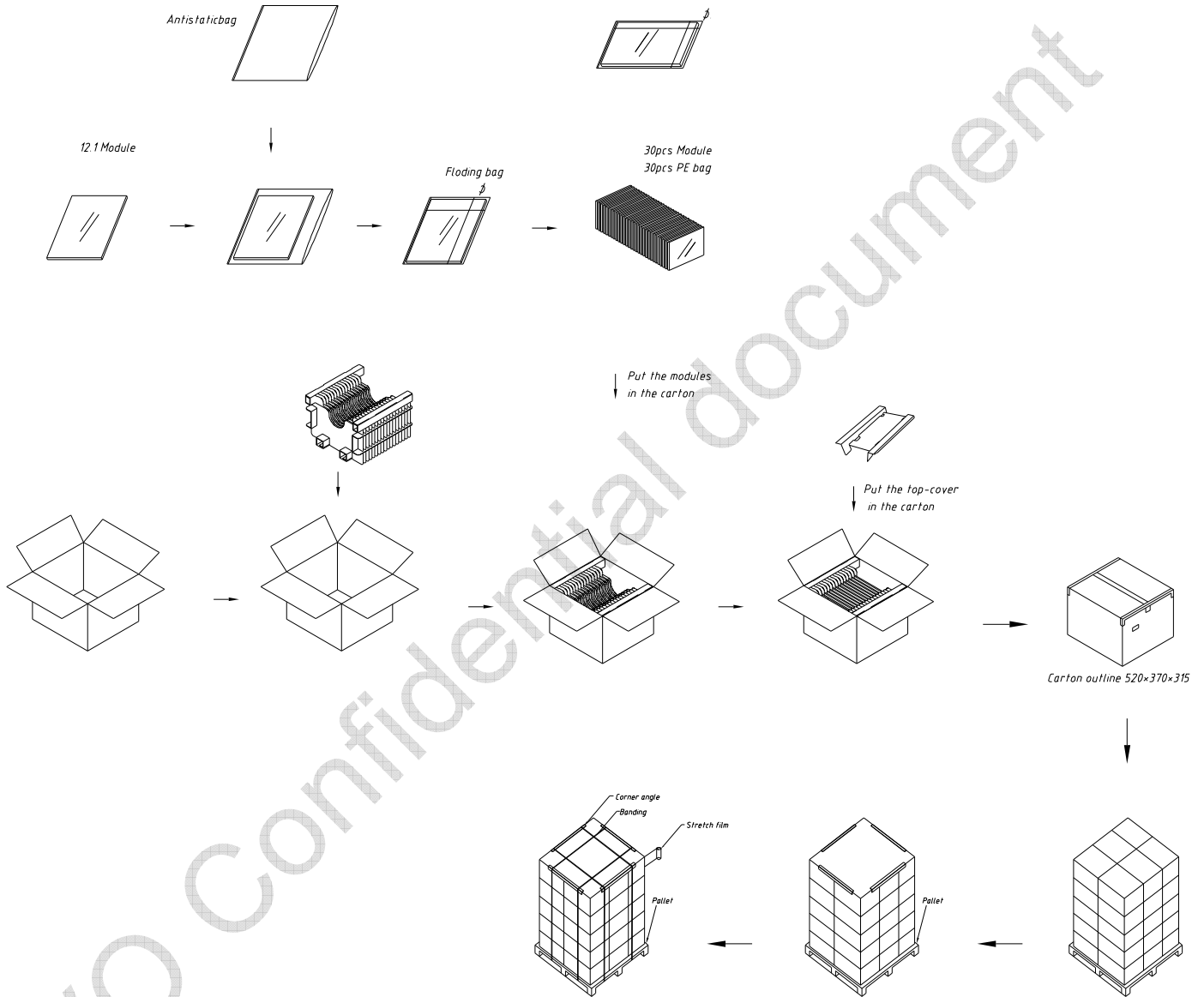

Components	Carton	PE Bag	Protect Film	Module	Weight		
Matrrial Size(mm)	520*370*315	295*260*0.06	254*194*0.08	279*209*9	545g/pcs Module(max)	19kg/carton	590kg/ Pallet
Amount	1pcs/carton	30pcs/carton	30pcs/carton	30pcs/carton		30pcs Module (Include Packing)	900pcs Module (Include Pacing)

Document Title	M121GNX2 R1 Product Information			Page No.	28/31
Document No.		Issue date	2013/11/25	Revision	03

12.0 Reliability Conditions

Item	Package	Test Conditions	Note
High Temperature Operation Test	Module	70°C, 300hrs	1,2,3,4,5,6
Low Temperature Operating Test	Module	-20°C, 300hrs	1,2,3,4,5,6
High Temperature Storage Test	Module	80°C, 300hrs	1,3,4,5,6
Low Temperature Storage Test	Module	-30°C, 300hrs	1,3,4,5,6
High Temp High Humidity Operating Test	Module	50°C, 85%, 300hrs	1,2,3,4,5,6

Note:

1. There is no function defect and occurrence of any new defective shall not be allowed.
2. In Operating test, the B/L voltage and current must be in spec.
3. All the judgments are under normal temperature and the sample need to be static more than 2 hours in the normal temperature before judge.
4. During measurement, the condensation water or remains shall not be allowed.
5. The minimum sample quantity of test is 3pcs.
6. There is no display function fail issue occurred, all the cosmetic specification is judged before the reliability stress.

Document Title	M121GNX2 R1 Product Information			Page No.	29/31
Document No.		Issue date	2013/11/25	Revision	03

13.1 Lot Mark

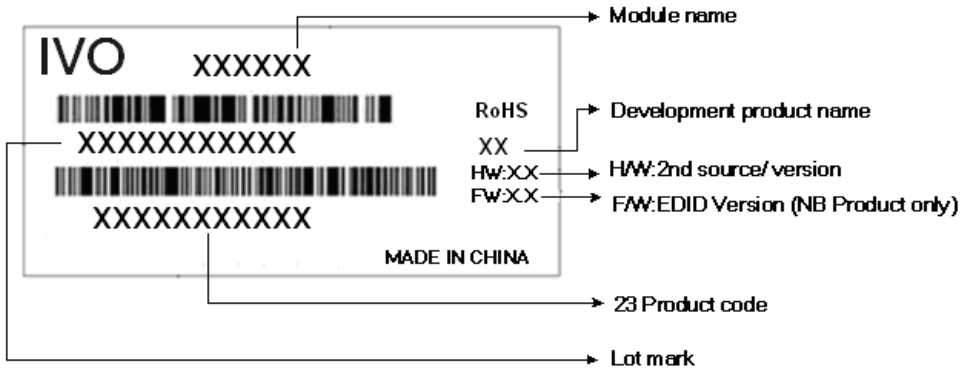

13.2 Lot Mark

1	2	3	4	5	6	7	8	9	10	11	12	13	14	15	16	17	18	19	20
---	---	---	---	---	---	---	---	---	----	----	----	----	----	----	----	----	----	----	----

code 1,2,4,5,6,7,8,9,10,11,16: IVO internal flow control code.
 code 3: Production location.
 code 12: Production year.
 code 13: Production month.
 code 14,15: Production date.
 code 17,18,19,20: Serial number.

Note (1) Production Year

Year	2,006	2,007	2,008	2,009	2,010	2,011	2,012	2,013	2,014	2,015
Mark	6	7	8	9	A	B	C	D	E	F

Note (2) Production Month

Month	Jan.	Feb.	Mar.	Apr.	May.	Jun.	Jul.	Aug.	Sep.	Oct	Nov.	Dec.
Mark	1	2	3	4	5	6	7	8	9	A	B	C

13.3 23 Product Barcode

1	2	3	4	5	6	7	8	9	10	11	12	13	14	15	16	17	18	19	20	21	22	23
---	---	---	---	---	---	---	---	---	----	----	----	----	----	----	----	----	----	----	----	----	----	----

code 1,2: Manufacture District.
 code 3,4,5,6,7: IVO internal module name.
 code 8,9,10,13,16: IVO internal flow control code.
 code 11,12: Cell location Suzhou defined as "SZ".
 code 14,15: Module line kunshan defined as "KS".
 code 17,18,19 : Year, Month, Day Refer to Note(1) and Note(2) of Lot Mark.
 code 20~23 : Serial Number.

Document Title	M121GNX2 R1 Product Information			Page No.	30/31
Document No.		Issue date	2013/11/25	Revision	03

14.0 General Precaution

14.1 Use Restriction

This product is not authorized for use in life supporting systems, aircraft navigation control systems, military systems and any other application where performance failure could be life-threatening or otherwise catastrophic.

14.2 Handling Precaution

- (1) Please mount LCD module by using mounting holes arranged in four corners tightly.
- (2) Do not disassemble or modify the module. It may damage sensitive parts inside LCD module, and may cause scratches or dust on the display. IVO does not warrant the module, if customers disassemble or modify the module.
- (3) If LCD panel is broken and liquid crystal spills out, do not ingest or inhale liquid Crystal, and do not contact liquid crystal with skin. If liquid crystal contacts mouth or eyes, rinse out with water immediately. If liquid crystal contacts skin or cloths, wash it off immediately with alcohol and Rinse thoroughly with water.
- (4) Disconnect power supply before handling LCD module
- (5) Refrain from strong mechanical shock and /or any force to the module.
- (6) Do not exceed the absolute maximum rating values, such as the supply voltage variation, input voltage variation, variation in parts' parameters, environmental temperature; etc otherwise LCD module may be damaged. It's recommended employing protection circuit for power supply.
- (7) Do not touch, push or rub the polarizer with anything harder than HB pencil lead. Use fingerstalls of soft gloves in order to keep clean display quality, when Persons handle the LCD module for incoming inspection or assembly.
- (8) When the surface is dusty, please wipe gently with absorbent cotton or other soft Material. When cleaning the adhesives, please use absorbent cotton wetted with a little Petroleum benzene or other adequate solvent.
- (9) Wipe off saliva or water drops as soon as possible. If saliva or water drops Contact with polarizer for a long time, they may causes deformation or color Fading.
- (10) Protection film must remove very slowly from the surface of LCD module to Prevent from electrostatic occurrence.
- (11) Because LCD module uses CMOS-IC on circuit board and TFT-LCD panel, it is Very weak to electrostatic discharge, Please be careful with electrostatic Discharge .Persons who handle the module should be grounded through adequate methods.
- (12) Do not adjust the variable resistor located on the module.

14.3 Storage Precaution

- (1) Please do not leave LCD module in the environment of high humidity and high temperature for a long time.
- (2) The module shall not be exposed under strong light such as direct sunlight.Otherwise, Display characteristics may be changed.
- (3) The module should be stored in a dark place. It is prohibited to apply sunlight or fluorescent light in storage.

14.4 Operation Precaution

- (1) Do not connect or disconnect the module in the "Power On" condition.
- (2) Power supply should always be turned on/off by "Power on/off sequence"
- (3) Module has high frequency circuits. Sufficient suppression to the electromagnetic



Document Title	M121GNX2 R1 Product Information			Page No.	31/31
Document No.		Issue date	2013/11/25	Revision	03

interference should be done by system manufacturers. Grounding and shielding methods may be important to minimize the interference.

- (4) After installation of the TFT Module into an enclosure, do not twist nor bend the TFT Module even momentary. At designing the enclosure, it should be taken into consideration that no bending/twisting forces are applied to the TFT Module from outside. Otherwise the TFT Module may be damaged.

14.5 Others

- (1) Ultra-violet ray filter is necessary for outdoor operation.
- (2) Avoid condensation of water which may result in improper operation or disconnection of electrode.
- (3) If the module keeps displaying the same pattern for a long period of time, the image may be "sticked" to the screen.
- (4) This module has its circuitry PCB's on the rear side and should be handled carefully in order not to be stressed.

14.6 Disposal

When disposing LCD module, obey the local environmental regulations.