

Document Title	M101GWN9 R0 Product Specification			Page No.	1/24
Document No.		Issue date	2014-11-26	Revision	00

Product Specification

To:

Product Name: M101GWN9 R0

Document Issue Date: 2014-11-26

Customer	InfoVision Optoelectronics
<p style="text-align: center;"><u>SIGNATURE</u></p> <p>_____</p> <p>_____</p> <p>_____</p> <p>Please return 1 copy for your confirmation with your signature and comments.</p>	<p style="text-align: center;"><u>SIGNATURE</u></p> <p style="text-align: center;">REVIEWED BY Q</p> <p>_____</p> <p>_____</p> <p style="text-align: center;">PREPARED BY FAE</p> <p>_____</p> <p>_____</p>

- Note:
1. Please contact InfoVision Company before designing your product based on this product.
 2. The information contained herein is presented merely to indicate the characteristics and performance of our products. No responsibility is assumed by IVO for any intellectual property claims or other problems that may result from application based on the module described herein.

FQ-7-30-0-009-02C

昆山龙腾光电有限公司

IVO InfoVision Optoelectronics (Kunshan)Co., Ltd.

Document Title	M101GWN9 R0 Product Specification			Page No.	2/24
Document No.		Issue date	2014-11-26	Revision	00

Revision	Date	Page	Old Description	New Description	Remark
00	2014-11-26	all	--	First issue.	

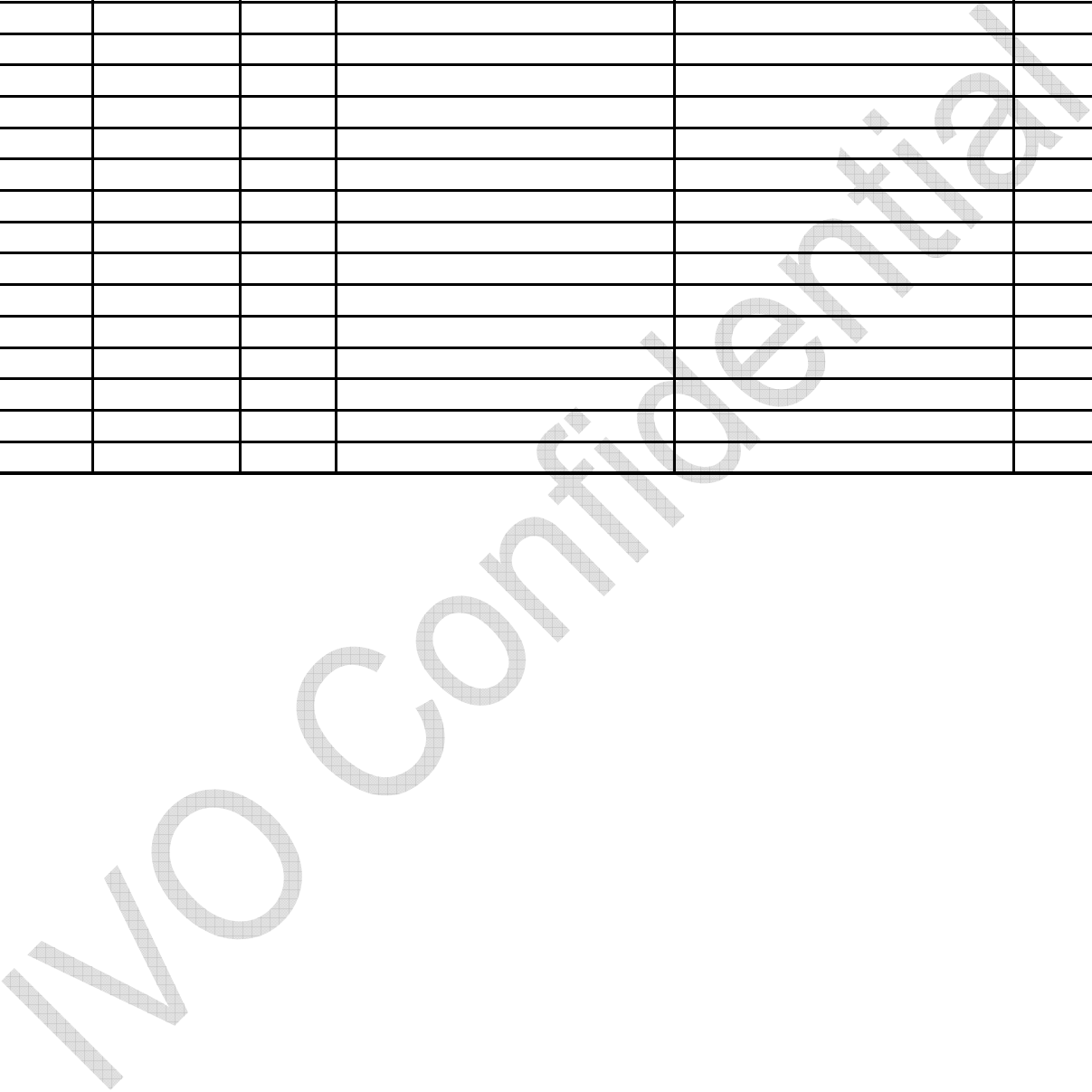

Document Title	M101GWN9 R0 Product Specification			Page No.	3/24
Document No.		Issue date	2014-11-26	Revision	00

Contents

1.0 GENERAL DESCRIPTIONS INTRODUCTION	4
2.0 ABSOLUTE MAXIMUM RATINGS	5
3.0 PIXEL FORMAT IMAGE	7
4.0 OPTICAL CHARACTERISTICS	8
5.0 BACKLIGHT CHARACTERISTICS	11
6.0 ELECTRICAL CHARACTERISTICS	11
7.0 INTERFACE TIMINGS	15
8.0 POWER CONSUMPTION	17
9.0 POWER ON/OFF SEQUENCE	17
10.0 RELIABILITY TEST CRITERIA	19
11.0 MECHANICAL CHARACTERISTICS	20
12.0 PACKAGE SPECIFICATION	21
13.0 LOT MARK	22
14.0 GENERAL PRECAUTION	23

IVO Confidential

Document Title	M101GWN9 R0 Product Specification			Page No.	4/24
Document No.		Issue date	2014-11-26	Revision	00

1.0 General Descriptions Introduction

1.1 Introduction

The M101GWN9 is a color active matrix thin film transistor (TFT) liquid crystal display (LCD) that uses amorphous silicon TFT as a switching device. It is composed of a TFT LCD panel, a backlight system, column driver and row driver circuit. This TFT LCD has a 10.1-inch diagonally measured active display area with WSVGA resolution (1024 horizontal by 600 vertical pixels array).

1.2 Features

- 10.1" TFT LCD Panel
- LED Backlight System
- Supported 1024x600 pixels resolution
- Compatible with RoHS standard

1.3 Product Summary

Items	Specifications	Unit
Screen Diagonal	10.1	Inch
Active Area	222.72(H) x 125.28(V)	mm
Pixels H x V	1024(RGB) x600	-
Pixel Pitch	0.2175(H) x 0.2088(V)	mm
Pixel Arrangement	RGB Vertical Stripe	-
Display Mode	Normally White	-
White Luminance	500 (Typ.)	cd /m ²
Contrast Ratio	500 (Typ.)	-
Response Time	16 (Typ.)	ms
Input Voltage	3.3 (Typ.)	V
Weight	440 (Max)	g
Outline Dimension (H x V x D)	244.0(Typ.)x 143.0(Typ.)x12.4(Typ.)	mm
Electrical Interface (Logic)	LVDS	-
Support Color	262K/16.7M	-
Surface Treatment	Anti-glare, Hard-Coating (3H)	-

Document Title	M101GWN9 R0 Product Specification			Page No.	5/24
Document No.		Issue date	2014-11-26	Revision	00

1.4 Functional Block Diagram

Figure 1 shows the functional block diagram of the LCD module.

Figure 2 Block Diagram

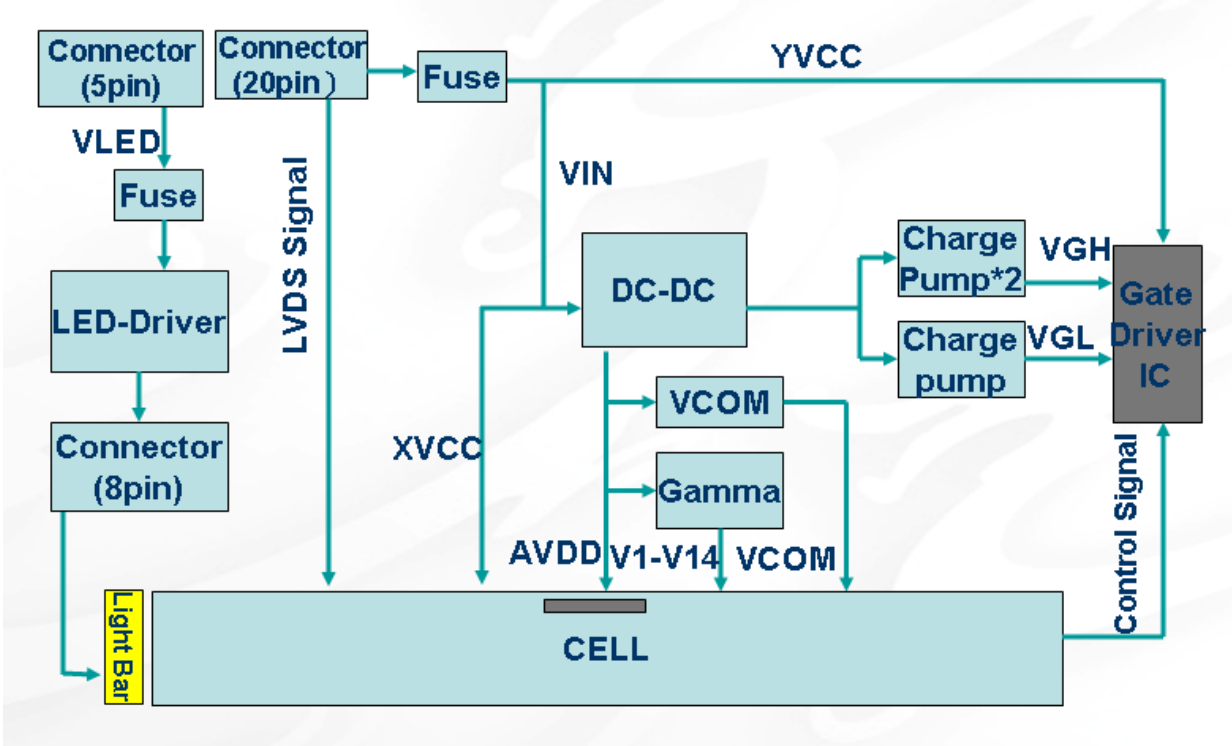

2.0 Absolute Maximum Ratings

Table 1 Electrical Absolute Rating

ITEM	SYMBOL	MIN.	MAX.	UNIT	REMARK
Supply Voltage	V_{IN}	-0.3	3.6	V	Logic power supply voltage
		-0.3	24	V	LED Driver Vin
Power Supply Fuse Current Setting	I_{FUSE}	-	1.5	A	Vin from 10% ~ 90% , rise time 500us
Input Signal	V_S	-	3.6	V	LVDS signals
PWM Voltage	V_{PWM}	0.8	5.0	V	PWM Dimming Voltage

Document Title	M101GWN9 R0 Product Specification			Page No.	6/24
Document No.		Issue date	2014-11-26	Revision	00

Table 2 Absolute Ratings of Environment

Item	Symbol	Min.	Max.	Unit	Conditions
Operating Temperature	TOP	-30	85	°C	(1),(2),(3),(4)
Operating Humidity	HOP	10	85	%RH	
Storage Temperature	TST	-30	85	°C	
Storage Humidity	HST	10	95	%RH	

Note (1): Humidity: 85%RH Max. (T<=40°C) Note static electricity. Maximum wet bulb temperature at 39°C or less. (T>40°C) No condensation.

Note (2): There is a possibility of causing deterioration in the irregularity and others of the screen and the display fineness though the liquid crystal module doesn't arrive at destruction when using it at 80~85°C or -30~0°C.

Note (3): There is a possibility of causing the fineness deterioration by the prolonged use in the (high temperature) humidity environment (60% or more).

Note (4): In the operating temperature item, the low temperature side is the ambient temperature regulations. The high temperature side is the panel surface temperature regulations.

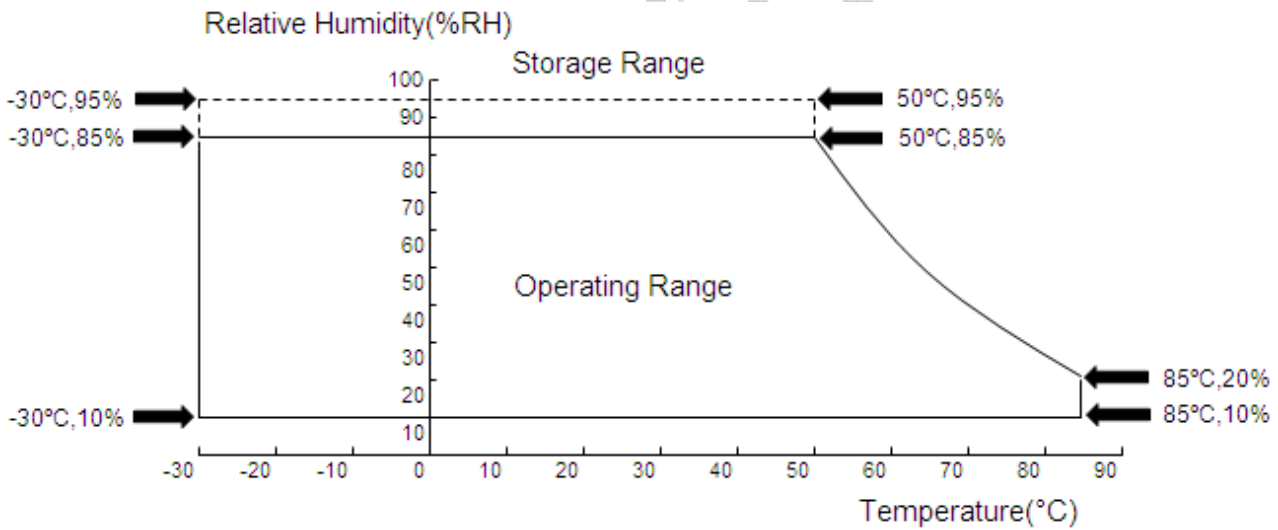

Document Title	M101GWN9 R0 Product Specification			Page No.	7/24
Document No.		Issue date	2014-11-26	Revision	00

3.0 Pixel Format Image

Figure 2 shows the relationship of the input signals and LCD pixel format image.

Figure 2 Pixel Format

REV=H

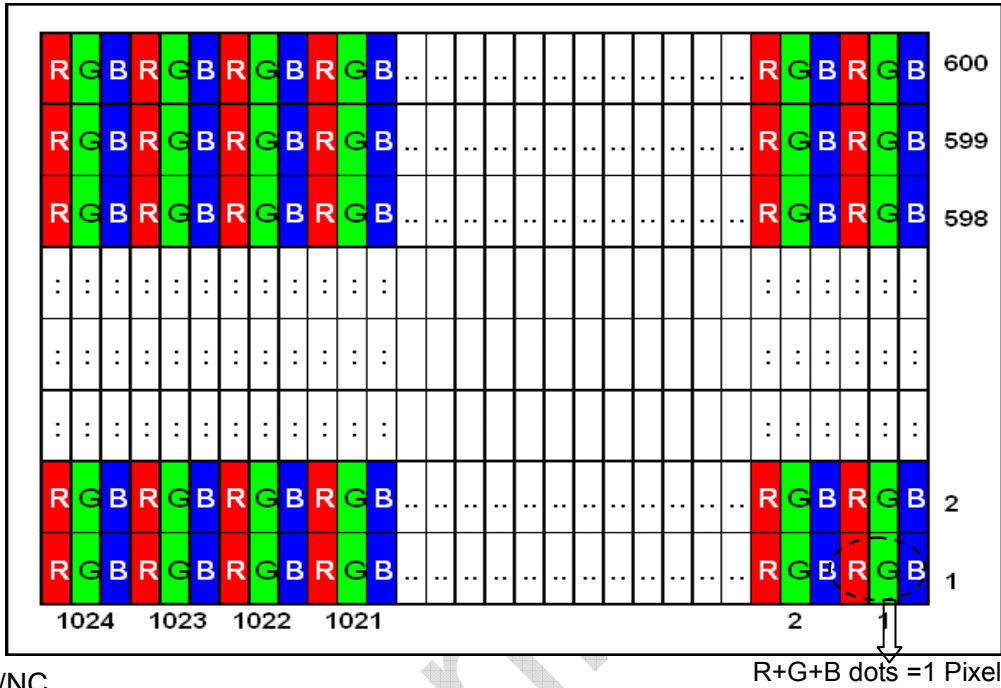

REV=L/NC

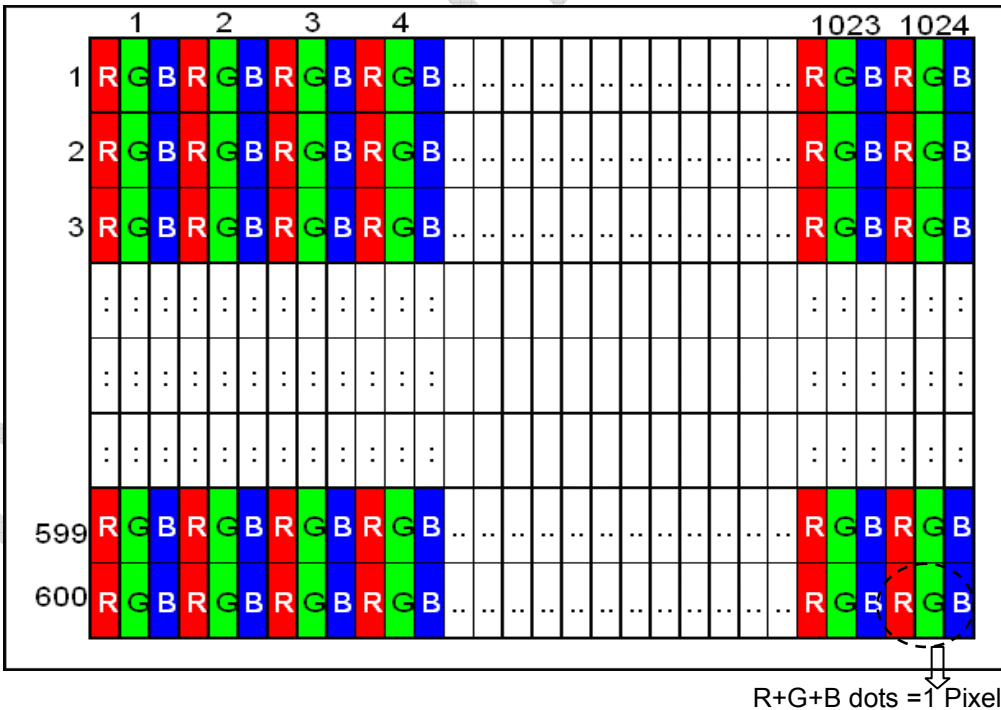

Document Title	M101GWN9 R0 Product Specification			Page No.	8/24
Document No.		Issue date	2014-11-26	Revision	00

4.0 Optical Characteristics

The optical characteristics are measured under stable conditions as following notes

Table 3 Optical Characteristics

Item	Conditions		Min.	Typ.	Max.	Unit	Note
Viewing Angle (CR>10)	Horizontal	θ_L	70	80	-	degree	(1),(2),(3)
		θ_R	70	80	-		
	Vertical	θ_T	70	80	-		
		θ_B	70	80	-		
Contrast Ratio	Center		400	500	-	-	(1),(2),(4)
Response Time	Rising		-	11	-	ms	(1),(2),(5)
	Falling		-	5	-	ms	
	Rising + Falling		-	16	20	ms	
Color Chromaticity (CIE1931)	NTSC		-	45	-	%	(1),(2)
	Red	x	Typ. -0.03	0.579	Typ. +0.03	-	(1),(2)
	Red	y		0.344		-	
	Green	x		0.326		-	
	Green	y		0.591		-	
	Blue	x		0.159		-	
	Blue	y		0.131		-	
	White	x		0.255		0.305	
	White	y	0.275	0.325	0.375	-	
White Luminance	Center		400	500	-	cd/m ²	(1),(2),(6)
Luminance Uniformity	9Points		75	80	-	%	(1),(2),(6)

Note (1) Measurement Setup:

The LCD module should be stabilized at given temperature(25°C) for 15 minutes to Avoid abrupt temperature change during measuring. In order to stabilize the luminance, the measurement should be executed after lighting backlight for 15 minutes in a windless room.

Document Title	M101GWN9 R0 Product Specification			Page No.	9/24
Document No.		Issue date	2014-11-26	Revision	00

Figure 3 Measurement Setup

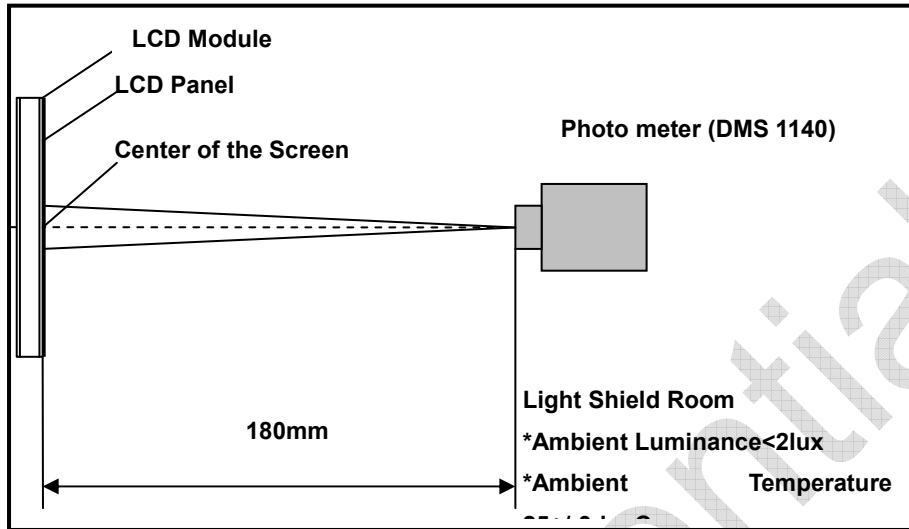

Note (2) The LED input parameter setting as:

VLED: 12V;

PWM_LED: Duty 100 %

Note (3) Definition of Viewing Angle

Figure 4 Definition of Viewing Angle

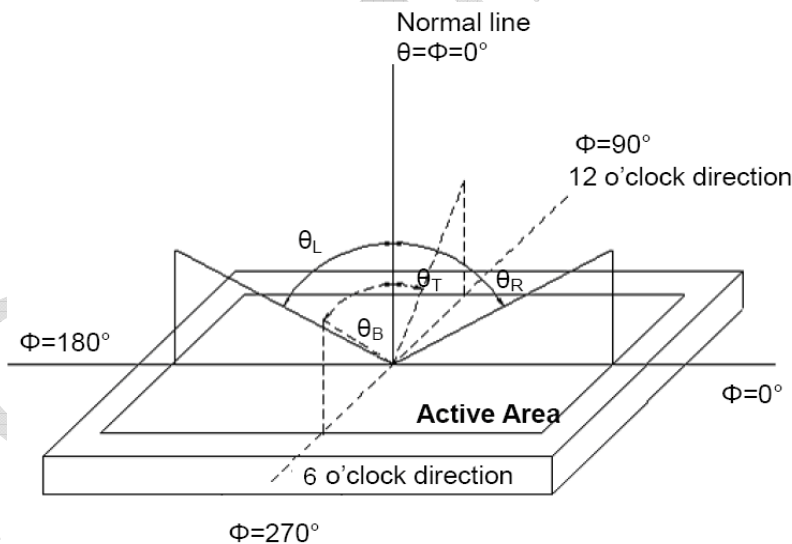

Note (4) Definition Of Contrast Ratio (CR)

The contrast ratio can be calculated by the following expression

$$\text{Contrast Ratio (CR)} = L_{63} (L_{255}) / L_0$$

L63 (L255): Luminance of gray level 63(6bit) or level 255(8bit),

L0: Luminance of gray level 0

Note (5) Definition Of Response Time (T_R , T_F)

Document Title	M101GWN9 R0 Product Specification			Page No.	10/24
Document No.		Issue date	2014-11-26	Revision	00

Figure 5 Definition of Response Time

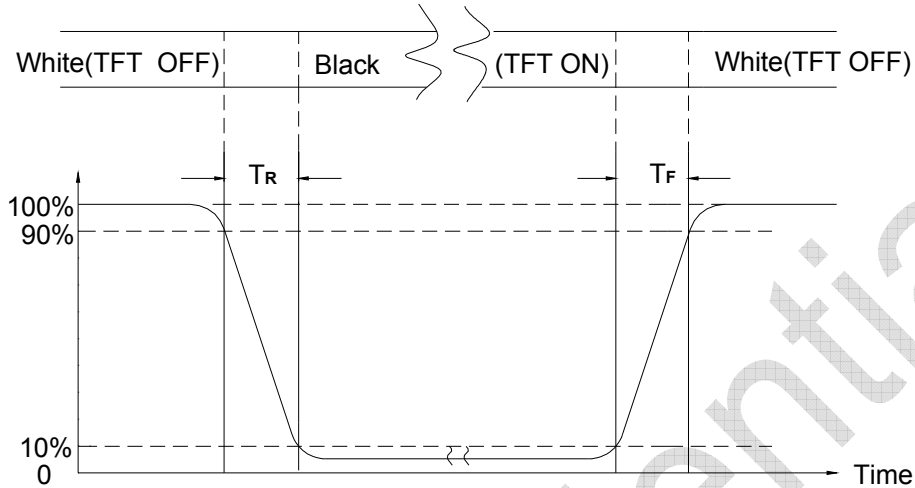

Note (6) Definition Of Brightness Luminance

$$\text{Luminance Uniformity} = \frac{(\text{Min Luminance of 9 points})}{(\text{Max Luminance of 9 points})} \times 100\%$$

Figure 6 Measurement Locations

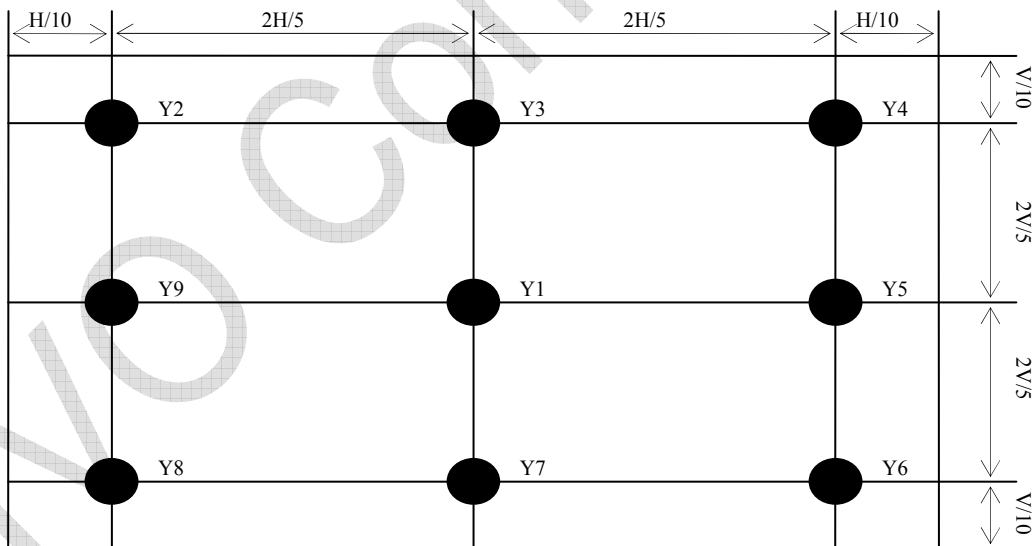

Document Title	M101GWN9 R0 Product Specification			Page No.	11/24
Document No.		Issue date	2014-11-26	Revision	00

5.0 Backlight Characteristics

Table 4 LED driver Input and Output Specifications

ITEM	UNIT	MIN	TYP	MAX	CONDITION
VIN_LED	V	8	12	16	DUTY=100%
I _{VIN_LED}	mA	-	-	543	
F _{DIM}	HZ	100	-	1K	
DUTY	%	5		100	
CTRL	VIH	V	3.3	5	
	VIL	V	-	0.8	
V _{out}	V	-	(22.4)	-	
I _{OUT}	mA	-	(160)		
效率	%	(80)			
L _T	Hours	50,000	-	-	LED Life Time

Note : The LED life time define as the estimated time to 50% degradation of initial luminous.

6.0 Electrical Characteristics

Table 5 Connector Name / Designation

Item	Description
Signal Connector	STM MSB240420HD
LED Connector	STM MSB24038P5A

Document Title	M101GWN9 R0 Product Specification			Page No.	12/24
Document No.		Issue date	2014-11-26	Revision	00

Table 6 Signal Pin Assignment

Pin #	Signal Name	Description	Remarks
1	VDD	Power Supply, 3.3V (typical)	
2	VDD	Power Supply, 3.3V (typical)	
3	VSS	Ground	
4	REV	Reverse Scan selection	
5	Rin1-	-LVDS differential data input	
6	Rin1+	+LVDS differential data input	
7	VSS	Ground	
8	Rin2-	-LVDS differential data input	
9	Rin2+	+LVDS differential data input	
10	VSS	Ground	
11	Rin3-	-LVDS differential data input	
12	Rin3+	+LVDS differential data input	
13	VSS	Ground	
14	CIKIN-	-LVDS differential clock input	
15	CIKIN+	+LVDS differential clock input	
16	GND	Ground	
17	Rin4-	-LVDS differential data input	
18	Rin4+	+LVDS differential data input	
19	SEL68	6/8 bits LVDS data input selection(H:8bit ;L/Floating:6bit)	Table 7
20	NC	Not connection	High Active

Table 7 SEL68 Power Voltage Specifications

Signal Name	SYMBOL	MIN.	TYP.	MAX.	UNIT
SEL68	VH	2.0	3.3	5.0	V
	VL	-	-	0.8	V

Document Title	M101GWN9 R0 Product Specification			Page No.	13/24
Document No.		Issue date	2014-11-26	Revision	00

Table 8 B/L Pin Assignment

Pin #	Signal Name	Description	Remarks
1	VCC	Power Supply, 12V (typical)	
2	GND	Ground	
3	EN	3.3V (typical)	
4	PWM	3.3V (typical)	
5	NC	Not Connection	

IVO Confidential

Document Title	M101GWN9 R0 Product Specification			Page No.	14/24
Document No.		Issue date	2014-11-26	Revision	00

Table 9 Electrical Characteristics

ITEM	SYMBOL	MIN.	TYP.	MAX.	UNIT	CONDITIONS
System Power Supply						
Input Power Supply Voltage	V_{IN}	3.0	3.3	3.6	V	
Input Power Supply Current	I_{VIN}	-	-	191	mA	Black pattern 60Hz
Input Inrush Current	I_{RUSH}	-	-	1.5	A	0.5ms rise time (10%~90%)
Input Power Voltage Ripple	V_{RPL}	-	-	200	mV	Vp-p
REV	VH	2.0	3.3	5.0	V	
	VL	-	-	0.8	V	
LED Power Supply						
Input Power Supply Voltage	V_{LED-IN}	8	12	16	V	
Input Power Supply Current	I_{IN}	-	-	543	mA	
EN/PWM	VH	2.0	3.3	5.0	V	
	VL	-	-	0.8	V	
LVDS Signals						
Differential Input High Threshold	V_{th}	-	-	+100	mV	$V_{cm}=+1.2V$
Differential Input Low Threshold	V_{tl}	-100	-	-	mV	$V_{cm}=+1.2V$
Magnitude Differential Input Voltage	$ V_{id} $	200	-	600	mV	
Common Mode Voltage	V_{cm}	1.0	1.2	1.4	V	$V_{th} - V_{tl} = 200mV$
Common Mode Voltage Offset	ΔV_{cm}	-50	-	+50	mV	$V_{th} - V_{tl} = 200mV$

Note: A. Input signals shall be low or Hi-Z state when VIN is off.

B. All electrical characteristics for LVDS signal are defined and shall be measured at the interface connector of LCD.

C. White Pattern at 3.3V driving voltage.

Document Title	M101GWN9 R0 Product Specification			Page No.	15/24
Document No.		Issue date	2014-11-26	Revision	00

7.0 Interface Timings

7.1 Timing Characteristics

Table 10 Interface Timings

Synchronization Method : DE only

Parameter	Symbol	Unit	Min.	Typ.	Max.
LVDS Clock Frequency <single>	f_{dck}	MHz	45	51.2	57
H Total Time	T_{hp}	clocks	1,324	1,344	1,364
H Active Time	HA	clocks	1,024	1,024	1,024
H Blanking Time	T_{HBLANK}	clocks	300	320	340
V Total Time	T_{vp}	lines	625	635	645
V Active Time	VA	lines	600	600	600
V Blanking Time	T_{VBLANK}	lines	25	35	45
V Frequency	f_v	Hz	55	60	65

Figure 7 DE-only timing mode

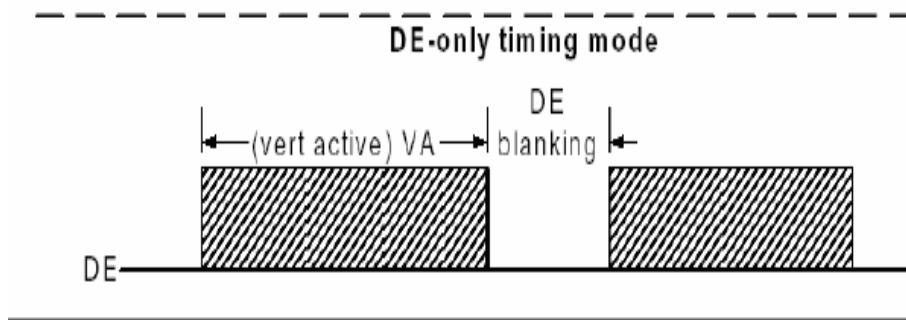

Document Title	M101GWN9 R0 Product Specification			Page No.	16/24
Document No.		Issue date	2014-11-26	Revision	00

7.2 Timing Diagram of Interface Signal

Figure 8 LVDS Data Mapping

6 bit LVDS input

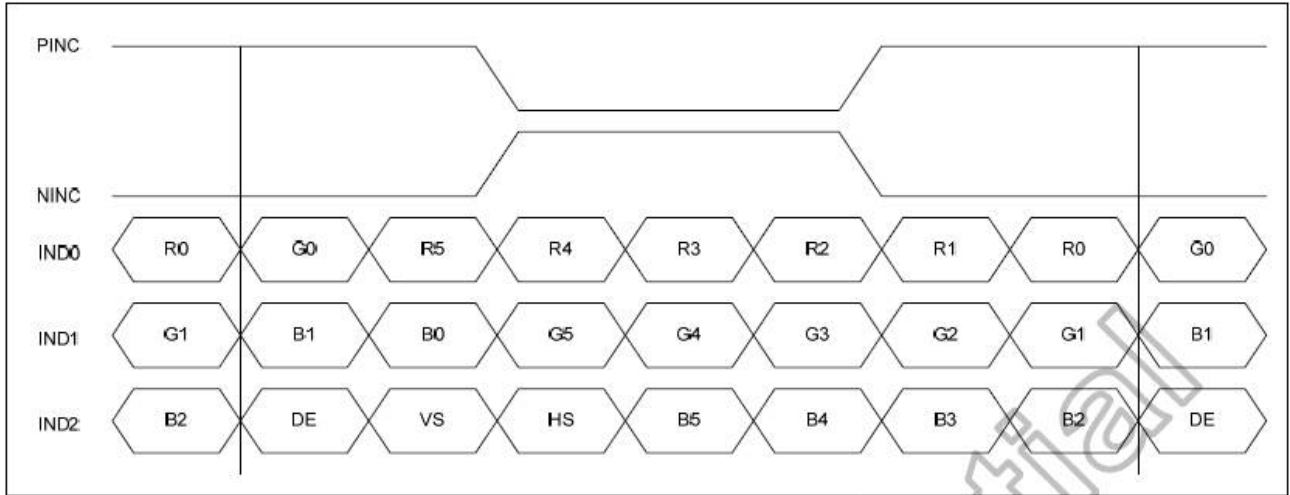

8 bit LVDS input

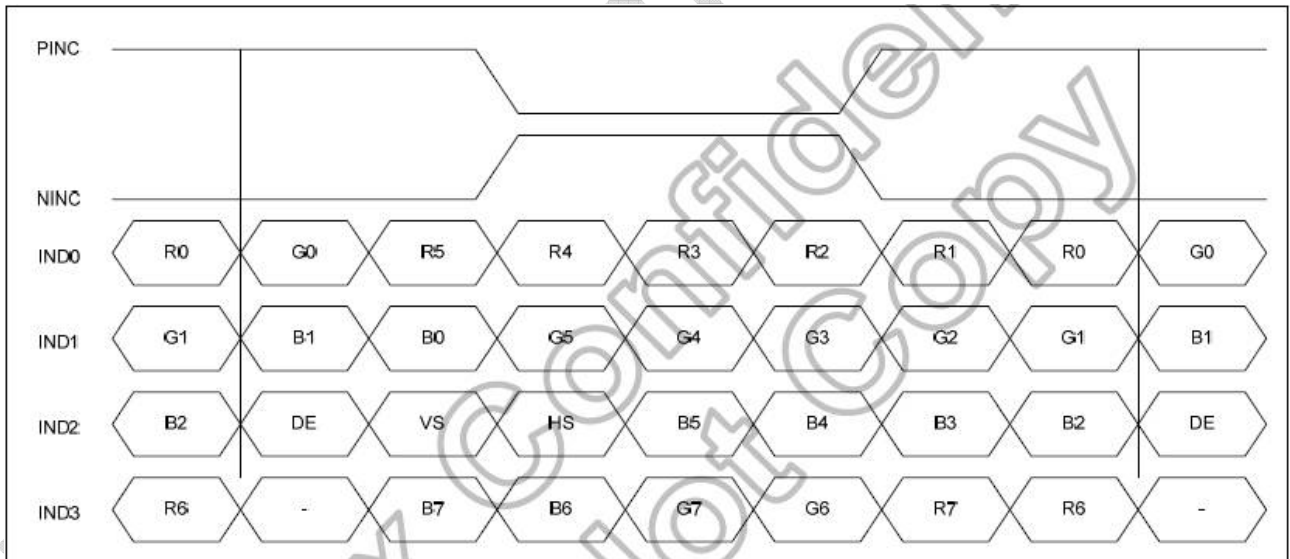

Document Title	M101GWN9 R0 Product Specification			Page No.	17/24
Document No.		Issue date	2014-11-26	Revision	00

8.0 Power Consumption

Input power specifications are as follows.

Table 11 Power Consumption

Item	Symbol	Min.	Typ.	Max.	Units	Note
Input Power Supply Voltage	V_{IN}	3.0	3.3	3.6	V	
Input Power Supply Current	I_{VIN}	-	-	191	mA	Black pattern, 60Hz
Input Inrush Current	I_{RUSH}	-	-	1.5	A	0.5ms rise time (10%~90%)
Input Power Voltage Ripple	V_{RPL}	-	-	200	mV	Vp-p

9.0 Power ON/OFF Sequence

Figure 9 Power Sequence

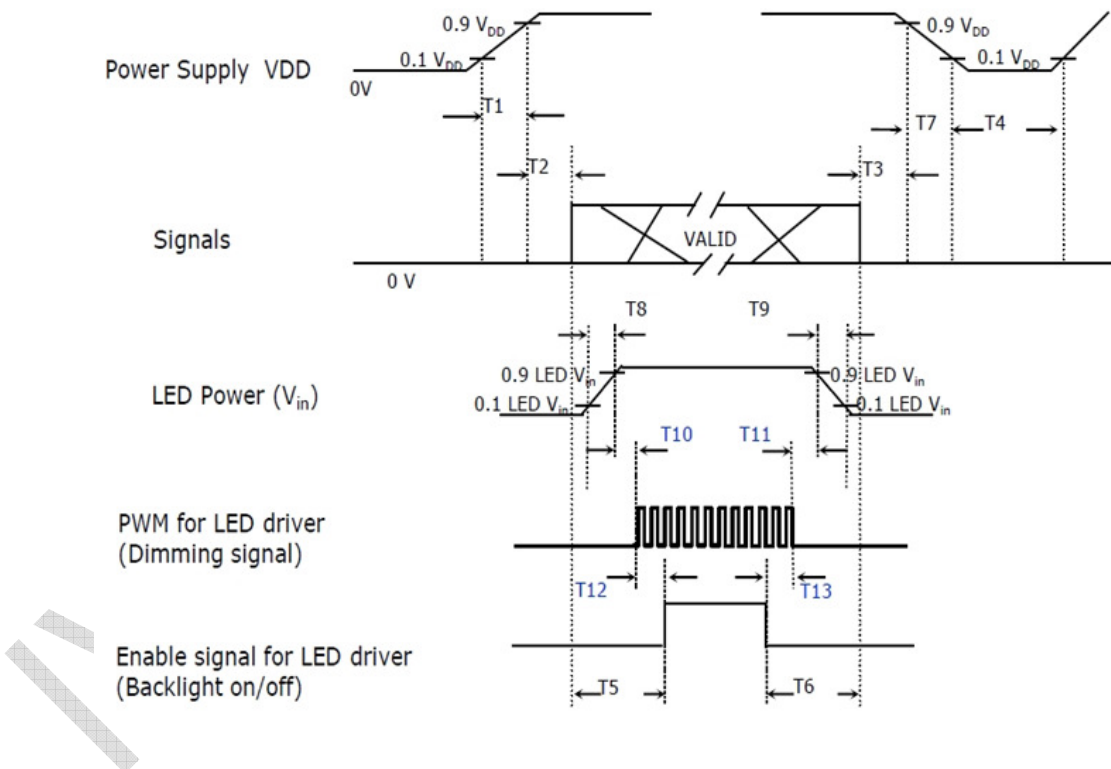

Document Title	M101GWN9 R0 Product Specification			Page No.	18/24
Document No.		Issue date	2014-11-26	Revision	00

Table 12 Power Sequencing Requirements

Parameter	Symbol	Unit	min	typ	max
VDD rising Time from 10% to 90%	T1	ms	0.5	--	10
Delay from VDD to valid data at power ON	T2	ms	0	--	50
Delay from valid data OFF to VDD OFF at power OFF	T3	ms	0	--	50
VDD OFF time for Windows restart	T4	ms	500	--	--
Delay from valid data to B/L enable at power ON	T5	ms	200	--	--
Delay from valid data off to B/L disable at power OFF	T6	ms	200	--	--
VDD falling time from 90% to 10%	T7	ms	0	--	10
LED Vin rising time from 10% to 90%	T8	ms	0.5	--	10
LED Vin falling time from 90% to 10%	T9	ms	0.5	--	10
Delay from LED driver Vin rising time 90% to PWM ON	T10	ms	0	--	10
Delay from PWM Off to LED Driver Vin falling time 10%,Must Keep rule	T11	ms	0	--	--
Delay from PWM ON to B/L Enable ON, Must Keep rule	T12	ms	0	--	--
Delay from B/L Enable Off to PWM Off	T13	ms	0	--	--

IVO Confidential

Document Title	M101GWN9 R0 Product Specification			Page No.	19/24
Document No.		Issue date	2014-11-26	Revision	00

10.0 Reliability Test Criteria

Table 13 Reliability Test Criteria

Items	Required Condition	Note
Temperature Humidity Bias	50°C, 85%, 300hrs	
High Temperature Operation	85°C, 300hrs	
Low Temperature Operation	-30°C, 300hrs	
High Temperature Storage	85°C, 300hrs	
Low Temperature Storage	-30°C, 300hrs	
Thermal Shock Test	-20°C~60°C, 1h/each cycle, 100cycles	
Shock Test (Non-Operating)	50G, 20ms, Half Sine Wave, (±X, ±Y, ±Z)	
Vibration Test (Non-Operating)	1.5G, 10~200 Hz, x、y、z each axis/30min	
ESD test	Contact Discharge: ±8KV, 150pF(330 Ω) ; Air Discharge: ±15KV, 150pF(330 Ω)	Note 1

Note1: ESD class C: Performance could be recovered by reset if temporary failure happened.

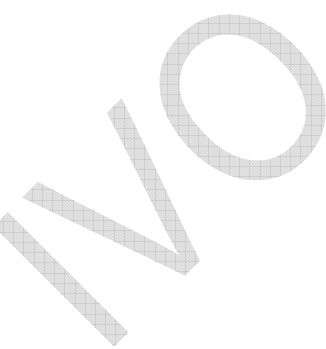

Document Title	M101GWN9 R0 Product Specification			Page No.	20/24
Document No.		Issue date	2014-11-26	Revision	00

11.0 Mechanical Characteristics

11.1 Outline Drawing

Figure 10 Reference Outline Drawing (Front Side)

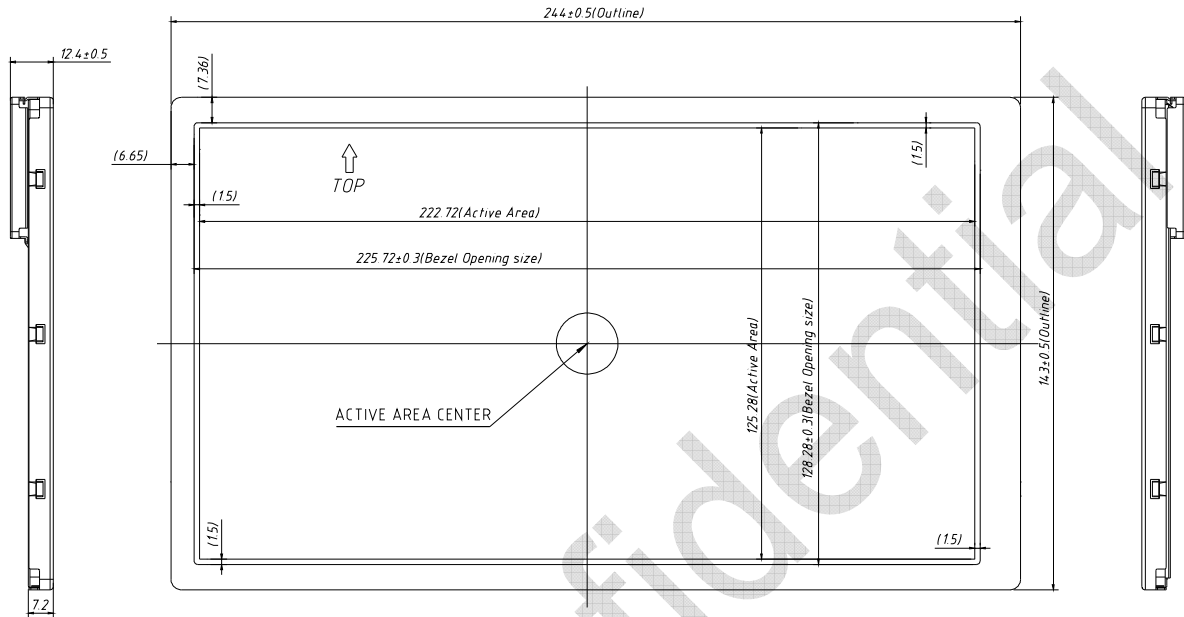
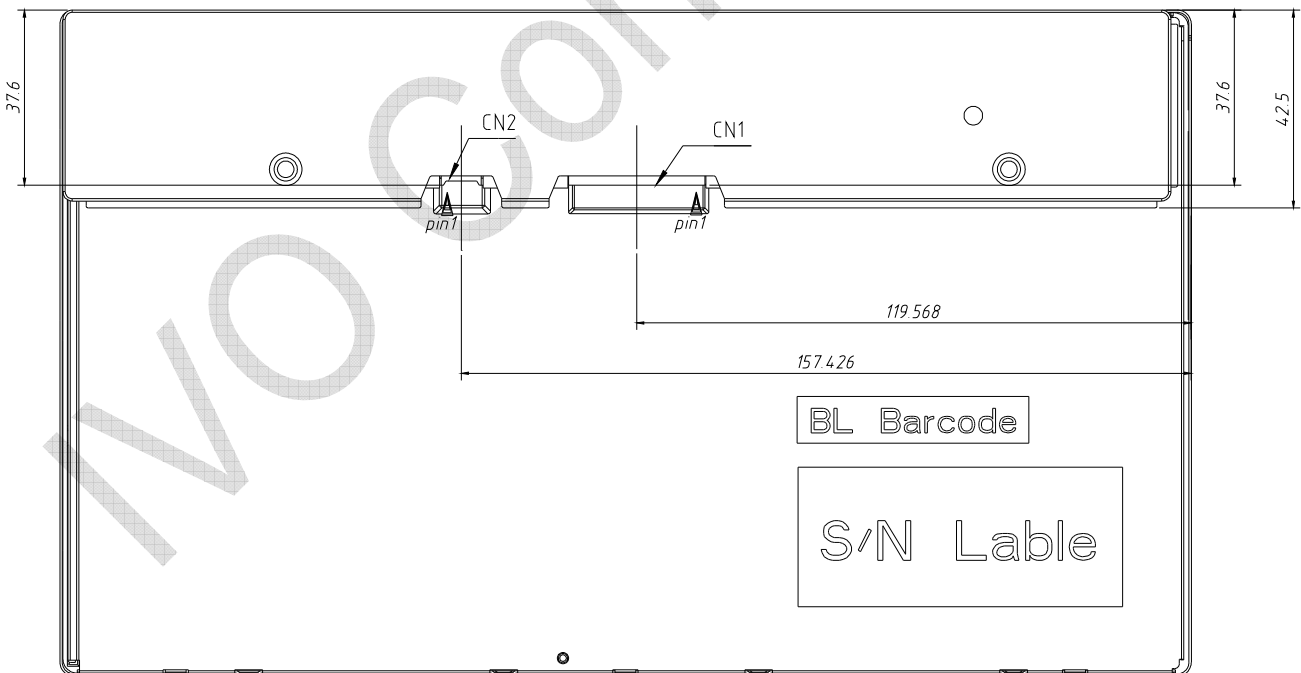

Figure 11 Reference Outline Drawing (Back Side)



Document Title	M101GWN9 R0 Product Specification			Page No.	21/24
Document No.		Issue date	2014-11-26	Revision	00

11.2 Dimension Specifications

Table 14 Module Dimension Specifications

Item	Min.	Typ.	Max.	Units
Width	243.5	244	244.5	mm
Height	142.5	143	143.5	mm
Thickness	-	12.4	12.9	mm
Weight	-	400	440	g

12.0 Package Specification

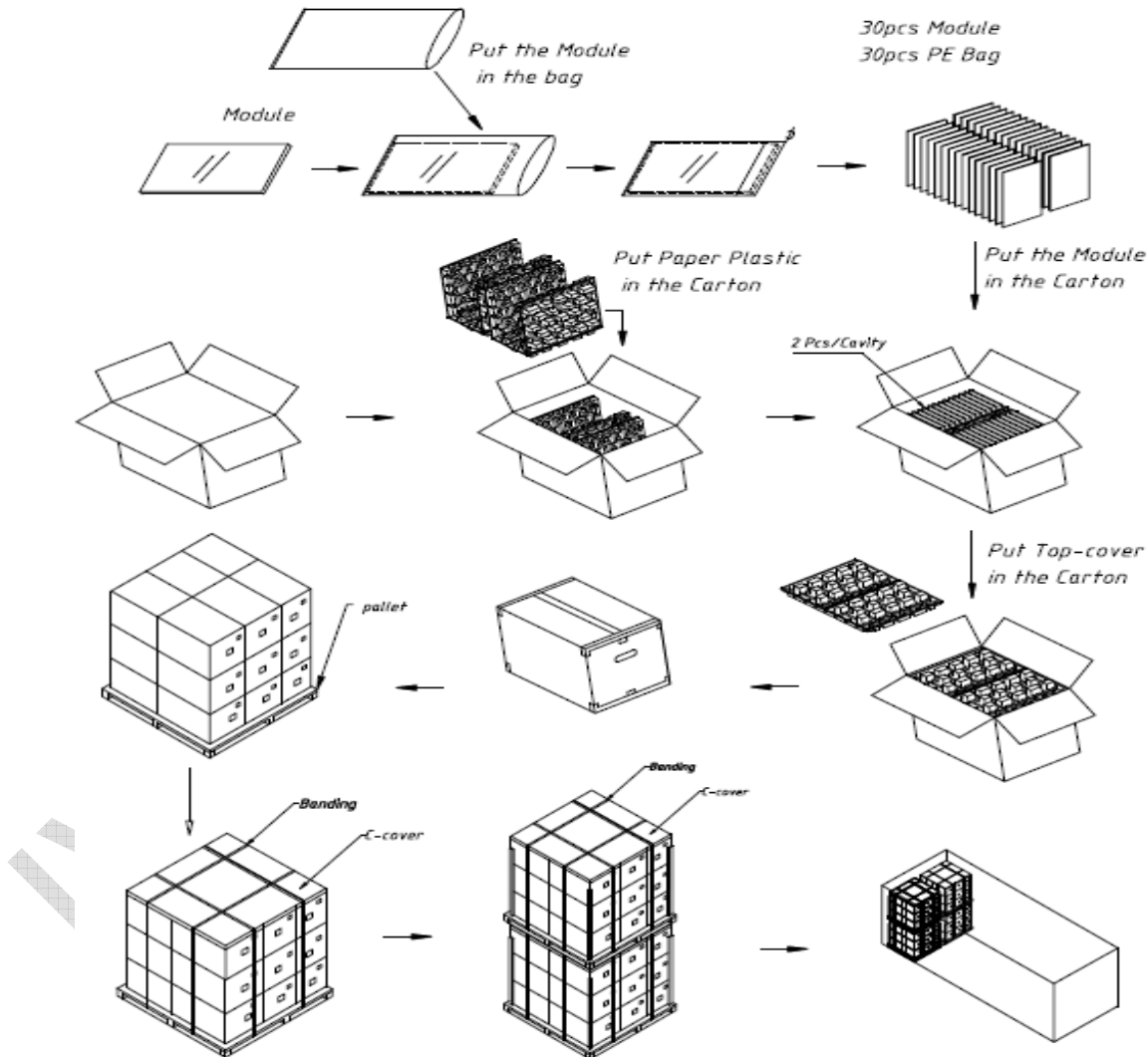

Document Title	M101GWN9 R0 Product Specification			Page No.	22/24
Document No.		Issue date	2014-11-26	Revision	00

13.0 Lot Mark

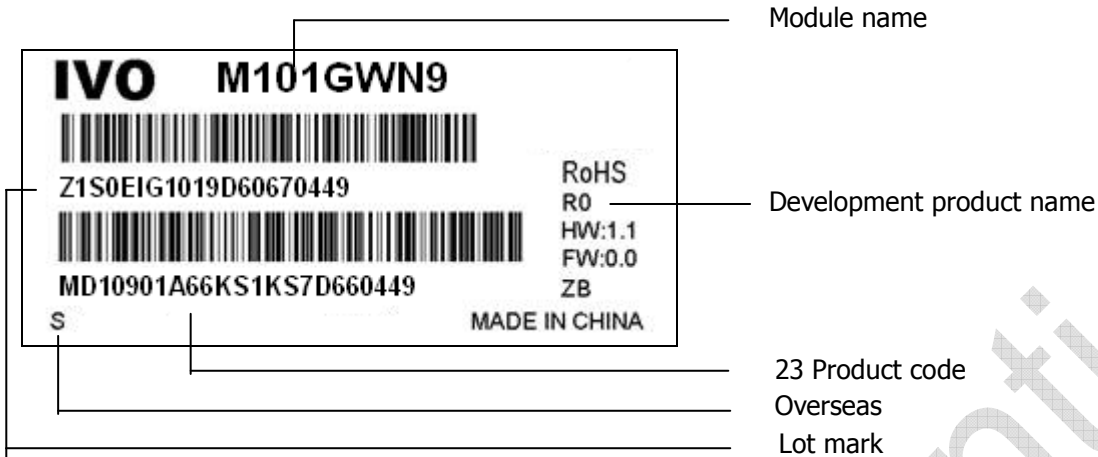

Note: This picture is only a sample.

13.1 Lot Mark

1	2	3	4	5	6	7	8	9	10	11	12	13	14	15	16	17	18	19	20
---	---	---	---	---	---	---	---	---	----	----	----	----	----	----	----	----	----	----	----

Code1,2,4,5,6,7,8,9,10,11,16: IVO internal flow control code.
 Code3: Production location.
 Code12: Production year.
 Code13: Production month.
 Code14, 15: Production date.
 Code17, 18, 19, 20: Serial number.

Note (1) Production Year

Year	2006	2007	2008	2009	2010	2011	2012	2013	2014	2015
Mark	6	7	8	9	A	B	C	D	E	F

Note (2) Production Month

Month	Jan.	Feb.	Mar.	Apr.	May.	Jun.	Jul.	Aug.	Sep.	Oct	Nov.	Dec.
Mark	1	2	3	4	5	6	7	8	9	A	B	C

13.2 23 Product Barcode

1	2	3	4	5	6	7	8	9	10	11	12	13	14	15	16	17	18	19	20	21	22	23
---	---	---	---	---	---	---	---	---	----	----	----	----	----	----	----	----	----	----	----	----	----	----

Code1, 2: Manufacture District.
 Code3, 4, 5, 6, 7: IVO internal module name.
 Code8, 9, 10, 13, 16: IVO internal flow control code.
 Code11, 12: Cell location Suzhou defined as "SZ".
 Code14, 15: Module line Kunshan defined as "KS".
 Code17, 18, 19: Year, Month, Day Refer to Note (1) and Note (2) of Lot Mark.
 Code20~23: Serial Number.

Document Title	M101GWN9 R0 Product Specification			Page No.	23/24
Document No.		Issue date	2014-11-26	Revision	00

14.0 General Precaution

14.1 Use Restriction

This product is not authorized for use in life supporting systems, aircraft navigation control systems, military systems and any other application where performance failure could be life-threatening or otherwise catastrophic.

14.2 Handling Precaution

- (1) Please mount LCD module by using mounting holes arranged in four corners tightly.
- (2) Do not disassemble or modify the module. It may damage sensitive parts inside LCD module, and may cause scratches or dust on the display. IVO does not warrant the module, if customers disassemble or modify the module.
- (3) If LCD panel is broken and liquid crystal spills out, do not ingest or inhale liquid Crystal, and do not contact liquid crystal with skin. If liquid crystal contacts mouth or eyes, rinse out with water immediately. If liquid crystal contacts skin or cloths, wash it off immediately with alcohol and Rinse thoroughly with water.
- (4) Disconnect power supply before handling LCD module
- (5) Refrain from strong mechanical shock and /or any force to the module.
- (6) Do not exceed the absolute maximum rating values, such as the supply voltage variation, input voltage variation, variation in parts' parameters, environmental temperature; etc otherwise LCD module may be damaged. It's recommended employing protection circuit for power supply.
- (7) Do not touch, push or rub the polarizer with anything harder than HB pencil lead. Use fingerstalls of soft gloves in order to keep clean display quality, when Persons handle the LCD module for incoming inspection or assembly.
- (8) When the surface is dusty, please wipe gently with absorbent cotton or other soft Material. When cleaning the adhesives, please use absorbent cotton wetted with a little Petroleum benzene or other adequate solvent.
- (9) Wipe off saliva or water drops as soon as possible. If saliva or water drops Contact with polarizer for a long time, they may causes deformation or color Fading.
- (10) Protection film must remove very slowly from the surface of LCD module to Prevent from electrostatic occurrence.
- (11) Because LCD module uses CMOS-IC on circuit board and TFT-LCD panel, it is Very weak to electrostatic discharge, Please be careful with electrostatic Discharge .Persons who handle the module should be grounded through adequate methods.
- (12) Do not adjust the variable resistor located on the module.

14.3 Storage Precaution

- (1) Please do not leave LCD module in the environment of high humidity and high temperature for a long time.
- (2) The module shall not be exposed under strong light such as direct sunlight. Otherwise, Display characteristics may be changed.
- (3) The module should be stored in a dark place. It is prohibited to apply sunlight or fluorescent light in storage.

14.4 Operation Precaution

- (1) Do not connect or disconnect the module in the "Power On" condition.
- (2) Power supply should always be turned on/off by 9.0 "Power on/off sequence"
- (3) Module has high frequency circuits. Sufficient suppression to the electromagnetic interference should be done by system manufacturers. Grounding and shielding

Document Title	M101GWN9 R0 Product Specification			Page No.	24/24
Document No.		Issue date	2014-11-26	Revision	00

methods may be important to minimize the interference.

- (4) After installation of the TFT Module into an enclosure, do not twist nor bend the TFT Module even momentary. At designing the enclosure, it should be taken into consideration that no bending/twisting forces are applied to the TFT Module from outside. Otherwise the TFT Module may be damaged.

14.5 Others

- (1) Ultra-violet ray filter is necessary for outdoor operation.
- (2) Avoid condensation of water which may result in improper operation or disconnection of electrode.
- (3) If the module keeps displaying the same pattern for a long period of time, the image may be "sticked" to the screen.
- (4) This module has its circuitry PCB's on the rear side and should be handled carefully in order not to be stressed.

14.6 Disposal

When disposing LCD module, obey the local environmental regulations.

IVO Confidential