



Document Title	M125NWR3 R0 Product Specification			Page No.	1/31
Document No.		Issue date	2015/06/19	Revision	01

Product specification

Product Name: M125NWR3 R0

Document Issue Date: 2015/06/19

- Note: 1. Please contact InfoVision Company. before designing your product based on this product.
2. The information contained herein is presented merely to indicate the characteristics and performance of our products. No responsibility is assumed by IVO for any intellectual property claims or other problems that may result from application based on the module described herein.

FQ-7-30-0-009-03C



InfoVision Optoelectronics (Kunshan)Co., Ltd.

Document Title	M125NWR3 R0 Product Specification			Page No.	2/31
Document No.		Issue date	2015/06/19	Revision	01

Revised Record				
Ver.	Date	Revised Content/Summary	Page	Revised By
00	2015/06/17	Tentative	All	
01	2015/06/19	Formal release	All	



Document Title	M125NWR3 R0 Product Specification			Page No.	3/31
Document No.		Issue date	2015/06/19	Revision	01

CONTENTS

1.0	GENERAL DESCRIPTIONS.....	3
2.0	ABSOLUTE MAXIMUM RATINGS.....	5
3.0	OPTICAL CHARACTERISTICS	6
4.0	ELECTRICAL CHARACTERISTICS.....	11
5.0	MECHANICAL CHARACTERISTICS.....	17
6.0	RELIABILITY CONDITIONS	19
7.0	PACKAGE SPECIFICATION	21
8.0	LOT MARK.....	19
9.0	GENERAL PRECAUTION.....	22
10.0	EDID TABLE FORMAT	22



Document Title	M125NWR3 R0 Product Specification			Page No.	4/31
Document No.		Issue date	2015/06/19	Revision	01

1.0 General Descriptions

1.1 Introduction

The M125NWR3 R0 is a color active matrix thin film transistor (TFT) liquid crystal display (LCD) that uses amorphous silicon TFT as a switching device. This model is composed of a TFT LCD panel, a driver circuit and a backlight system. This TFT LCD has a 12.5 inch diagonally measured active display area with HD resolution (1,366 horizontal by 768 vertical pixels array).

1.2 Features

- Supported HD Resolution
- eDP Interface
- Wide View Angle
- Compatible with RoHS Standard

1.3 Product Summary

Items	Specifications	Unit
Screen Diagonal	12.5	inch
Active Area (H x V)	275.59 x 154.94	mm
Number of Pixels (H x V)	1,366 x 768	-
Pixel Pitch (H x V)	0.2018 x 0.2018	mm
Pixel Arrangement	R.G.B. Vertical Stripe	-
Display Mode	Normally Black	-
White Luminance	300 (Typ.)	cd /m ²
Contrast Ratio	800 (Typ.)	-
Response Time	25 (Typ.)	ms
Input Voltage	3.3 (Typ.)	V
Power Consumption	3.2 (Max.)	W
Weight	230 (Max.)	g
Outline Dimension (H x V x D)	290.50 (Typ.) x 180.90(Typ.) x 2.85 (Max.)	mm
Electrical Interface (Logic)	eDP 1.2	-
Support Color	16.7M	-
NTSC	50 (Typ.)	%
Viewing Direction	All	-
Surface Treatment	AG-3H	-

Document Title	M125NWR3 R0 Product Specification			Page No.	5/31
Document No.		Issue date	2015/06/19	Revision	01

1.4 Functional Block Diagram

Figure 1 shows the functional block diagram of the LCD module.

Figure 1 Block Diagram

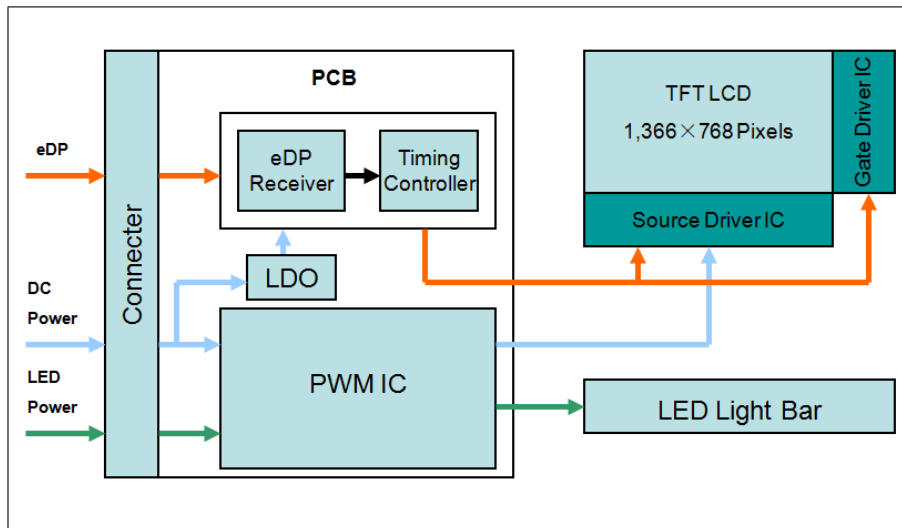

1.5 Pixel Mapping

Figure2 Pixel Mapping

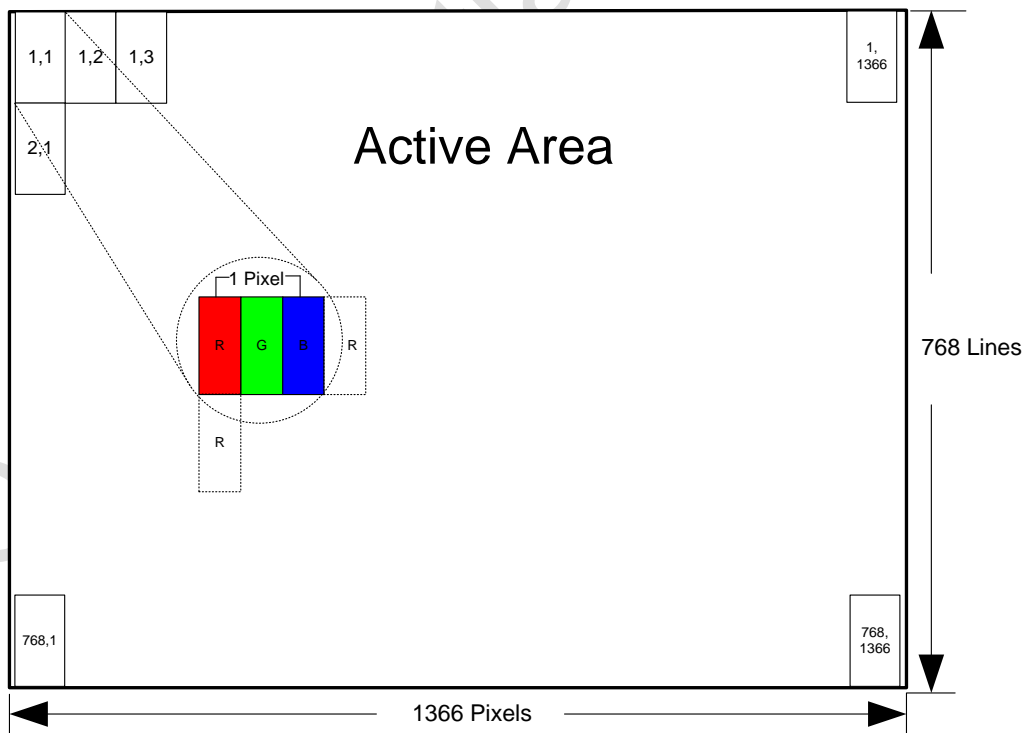



Document Title	M125NWR3 R0 Product Specification			Page No.	6/31
Document No.		Issue date	2015/06/19	Revision	01

2.0 Absolute Maximum Ratings

Table 1 Electrical & Environment Absolute Rating

Item	Symbol	Min.	Max.	Unit	Note
Logic Supply Voltage	V _{DD}	-0.3	4.0	V	(1),(2)
Logic Input Signal Voltage	V _{Signal}	0	2.7	V	
Operating Temperature	T _{OP}	0	60	°C	(3),(4),(5),(6)
Storage Temperature	T _{ST}	-30	70	°C	
Vibration(Non-operating)	VB	-	1.5	G	(7)
Shock(Non-operating)	Shock	-	210	G	(8)

Note (1) Permanent damage may occur to the LCD module if beyond this specification. Functional operation should be restricted to the conditions described under normal operating conditions.

Note (2) Operating temperature 25°C, humidity 55%RH.

Note (3) (T≤40°C) Note static electricity. Maximum wet bulb temperature at 39°C or less. (T>40°C) No condensation.

Note (4) There is a possibility of causing deterioration in the irregularity and others of the screen and the display fineness though the liquid crystal module doesn't arrive at destruction when using it at 60~70°C or -30~0°C.

Note (5) There is a possibility of causing the fineness deterioration by the prolonged use in the (high temperature) humidity environment (60%RH or more).

Note (6) In the operating temperature item, the low temperature side is the ambient temperature regulations. The high temperature side is the panel surface temperature regulations.

Note (7) 10-200Hz, random vibration, 30min for X, Y, Z axis.

Note (8) 210G,3ms, half sine wave, one time for X, Y, Z axis. 50G,18ms,Trapezoidal wave, one time for X, Y, Z axis.



Document Title	M125NWR3 R0 Product Specification			Page No.	7/31
Document No.		Issue date	2015/06/19	Revision	01

3.0 Optical Characteristics

The optical characteristics are measured under stable conditions as following notes.

Table 2 Optical Characteristics

Item	Conditions	Min.	Typ.	Max.	Unit	Note
Viewing Angle (CR>10)	Horizontal	θ_{x+}	80	85	-	degree (1),(2),(3)
		θ_{x-}	80	85	-	
	Vertical	θ_{y+}	80	85	-	
		θ_{y-}	80	85	-	
Contrast Ratio	Center	640	800	-	-	(1),(2),(4) $\theta_x=\theta_y=0^\circ$
Response Time	Rising + Falling	-	25	35	ms	(1),(2),(5) $\theta_x=\theta_y=0^\circ$
Color Chromaticity (CIE1931)	Red x	Typ. -0.03	0.590	Typ. +0.03	-	(1),(2),(3) $\theta_x=\theta_y=0^\circ$
	Red y		0.342		-	
	Green x		0.310		-	
	Green y		0.571		-	
	Blue x		0.173		-	
	Blue y		0.101		-	
	White x		0.313		-	
	White y		0.329		-	
NTSC	-	-	50	-	%	(1),(2),(3) $\theta_x=\theta_y=0^\circ$
White Luminance	5 Points Average	255	300	-	cd/m ²	(1),(2),(6) $\theta_x=\theta_y=0^\circ$
Luminance Uniformity	13 Points	60	-	-	%	(1),(2),(7) $\theta_x=\theta_y=0^\circ$

Note (1) Measurement Setup:

The LCD module should be stabilized at given temperature(25°C) for 15 minutes to avoid abrupt temperature change during measuring. In order to stabilize the luminance, the measurement should be executed after lighting backlight for 15 minutes in a windless room.

Document Title	M125NWR3 R0 Product Specification			Page No.	8/31
Document No.		Issue date	2015/06/19	Revision	01

Figure 3 Measurement Setup

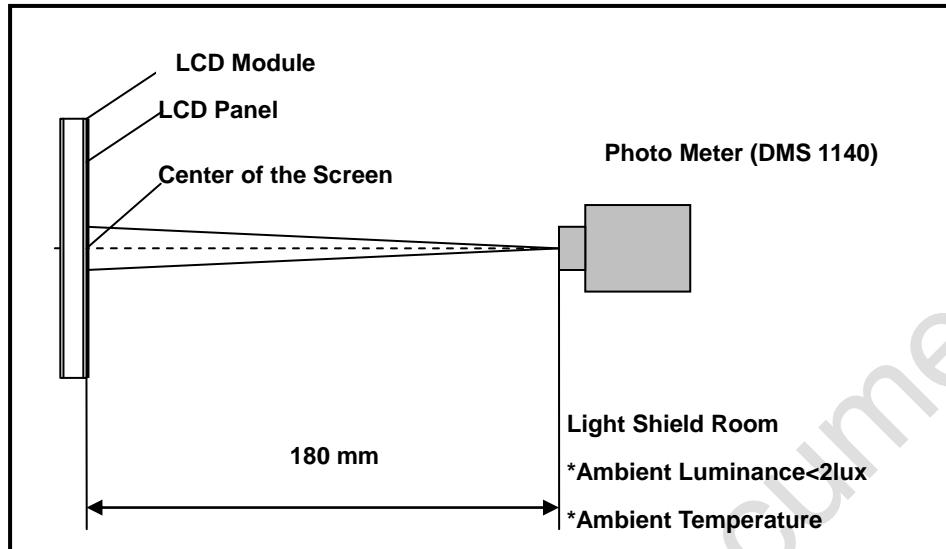

Note (2) The LED input parameter setting as:

I_LED: 80mA

PWM_LED: Duty 100 %

Note (3) Definition of Viewing Angle

Figure 4 Definition of Viewing Angle

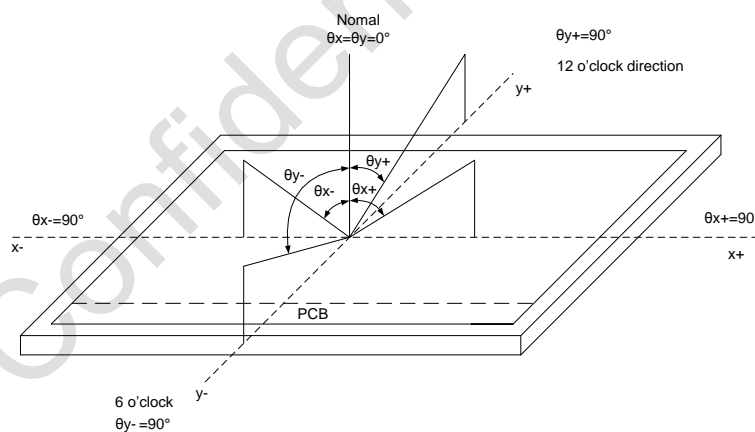

Note (4) Definition Of Contrast Ratio (CR)

The contrast ratio can be calculated by the following expression:

Document Title	M125NWR3 R0 Product Specification			Page No.	9/31
Document No.		Issue date	2015/06/19	Revision	01

Contrast Ratio (CR) = L63 / L0

L63: Luminance of gray level 63, L0: Luminance of gray level 0

Note (5) Definition Of Response Time (T_R , T_F)

Figure 5 Definition of Response Time

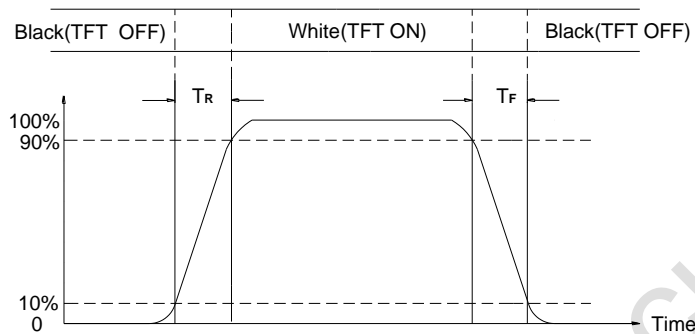

Note (6) Definition Of Luminance White

Measure the luminance of gray level 63 (Ref.: Active Area)

Display Luminance = $(L1 + L2 + L3 + L4 + L5) / 5$

Measure the luminance of gray level 63 (Ref.: Active Area)

Display Luminance = $(L1 + L2 + L3 + \dots + L9) / 9$

H—Active Area Width, V—Active Area Height, L—Luminance

Figure 6 Measurement Locations Of 5 Points

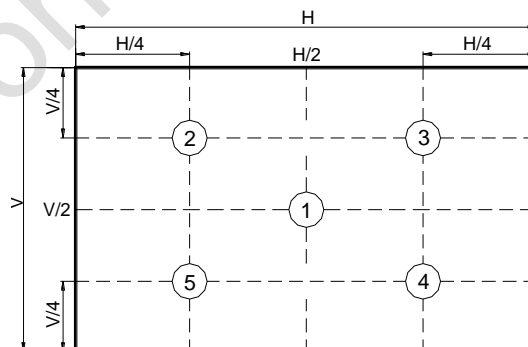

Note (7) Definition Of Luminance Uniformity (Ref.: Active Area)

Measure the luminance of gray level 63 at 13 points.

Luminance Uniformity = $\text{Min.}(L1, L2, \dots, L13) / \text{Max.}(L1, L2, \dots, L13)$

Document Title	M125NWR3 R0 Product Specification			Page No.	10/31
Document No.		Issue date	2015/06/19	Revision	01

H—Active Area Width, V—Active Area Height, L—Luminance

Figure 7 Measurement Locations Of 13 Points

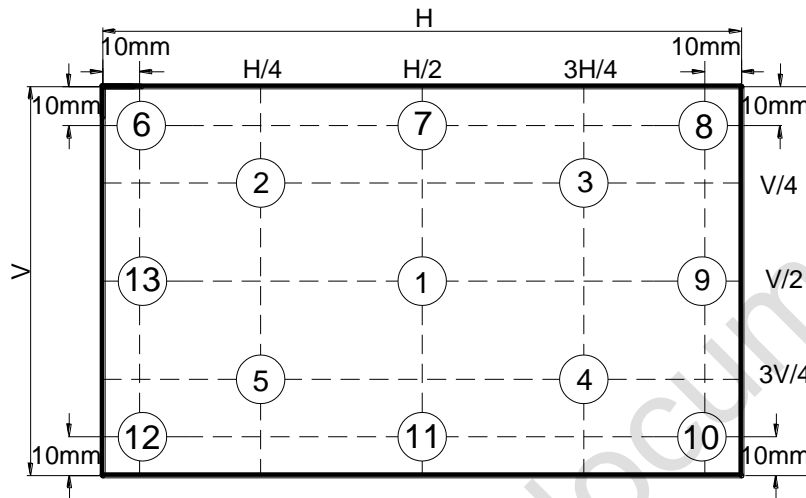



Document Title	M125NWR3 R0 Product Specification			Page No.	11/31
Document No.		Issue date	2015/06/19	Revision	01

4.0 Electrical Characteristics

4.1 Interface Connector

Table 3 Signal Connector Type

Item	Description
Manufacturer / Type	JAE HD2S030HA1

Table 4 Signal Connector Pin Assignment

Pin No.	Symbol	Description	Remarks
1	NC	No Connection	-
2	H_GND	High Speed Ground	-
3	NC	No Connection	-
4	NC	No Connection	-
5	H_GND	High Speed Ground	-
6	Lane0_N	Complement Signal Link Lane 0	-
7	Lane0_P	True Signal Link Lane 0	-
8	H_GND	High Speed Ground	-
9	AUX_CH_P	True Signal Auxiliary Channel	-
10	AUX_CH_N	Complement Signal Auxiliary Channel	-
11	H_GND	High Speed Ground	-
12	LCD_VCC	LCD logic and driver power	-
13	LCD_VCC	LCD logic and driver power	-
14	BIST	LCD Panel Self Test Enable	-
15	LCD_GND	LCD logic and driver ground	-
16	LCD_GND	LCD logic and driver ground	-
17	HPD	HPD signal pin	-
18	BL_GND	Backlight ground	-
19	BL_GND	Backlight ground	-
20	BL_GND	Backlight ground	-
21	BL_GND	Backlight ground	-
22	BL_ENABLE	Backlight On/Off	-
23	BL_PWM	System PWM signal input	-
24	HSS	Hsync similar signal	-
25	NC	No Connection	-
26	BL_PWR	Backlight power	-
27	BL_PWR	Backlight power	-
28	BL_PWR	Backlight power	-



InfoVision Optoelectronics (Kunshan)Co., Ltd.

Document Title	M125NWR3 R0 Product Specification			Page No.	12/31
Document No.		Issue date	2015/06/19	Revision	01

29	BL_PWR	Backlight power	-
30	NC	No Connection	-

IVO Confidential document

Document Title	M125NWR3 R0 Product Specification			Page No.	13/31
Document No.		Issue date	2015/06/19	Revision	01

4.2 Signal Electrical Characteristics

Table 5 Display Port Main Link

Parameter	Description	Min.	Typ.	Max.	Unit
V_{CM}	Differential Common Mode Voltage	0	-	2.0	V
$V_{Diff\ P-P}$ Level 1	Differential Peak to Peak Voltage Level 1	0.34	0.40	0.46	V
$V_{Diff\ P-P}$ Level 2	Differential Peak to Peak Voltage Level 2	0.51	0.60	0.68	V
$V_{Diff\ P-P}$ Level 3	Differential Peak to Peak Voltage Level 3	0.69	0.80	0.92	V
$V_{Diff\ P-P}$ Level 4	Differential Peak to Peak Voltage Level 4	1.02	1.20	1.38	V

Note: (1) Input signals shall be low or Hi- resistance state when VDD is off.

(2) It is recommended to refer the specifications of VESA Display Port Standard V1.2 in detail.

(3) Follow as VESA display port standard V1.2 at both 1.62 and 2.7Gbps link rates.

Figure 8 Display Port Main Link Signal

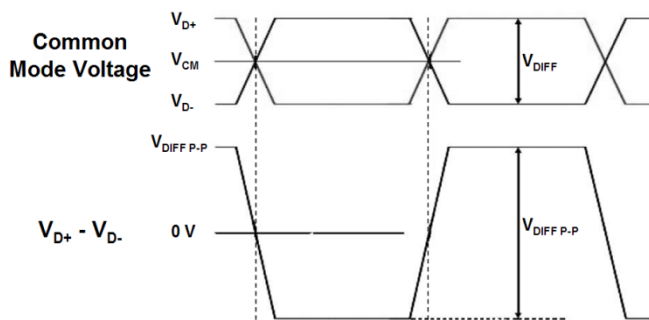

Figure 9 Display Port AUX_CH Signal

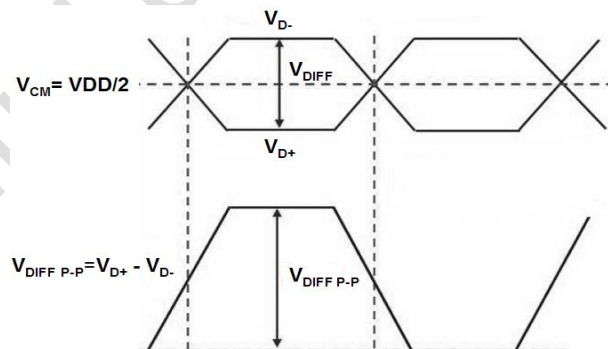

Table 6 Display Port AUX_CH

Parameter	Description	Min.	Typ.	Max.	Unit
V_{CM}	Differential Common Mode Voltage	0	VDD/2	2	V
$V_{Diff\ P-P}$	Differential Peak to Peak Voltage	0.39	-	1.38	V

Note: Follow as VESA display port standard V1.2.

Table 7 Display Port V_{HPD}

Parameter	Description	Min.	Typ.	Max.	Unit
V_{HPD}	HPD Voltage	2.25	-	3.60	V

Note: Follow as VESA display port standard V1.2.



Document Title	M125NWR3 R0 Product Specification			Page No.	14/31
Document No.		Issue date	2015/06/19	Revision	01

4.3 Interface Timings

Table 8 Interface Timings

Parameter	Symbol	Min.	Typ.	Max.	Unit
Clock Frequency	Fclk	69.2	72	80	MHz
H Total Time	HT	1,486	1,500	2,518	Clocks
H Active Time	HA	1,366	1,366	1,366	Clocks
V Total Time	VT	776	800	1,168	Lines
V Active Time	VA	768	768	768	Lines
Frame Rate	FV	55	60	65	Hz

Document Title	M125NWR3 R0 Product Specification			Page No.	15/31
Document No.		Issue date	2015/06/19	Revision	01

4.4 Input Power Specifications

Input power specifications are as follows.

Table 9 Input Power Specifications

Parameter	Symbol	Min.	Typ.	Max.	Unit	Note	
System Power Supply							
LCD Drive Voltage (Logic)	V_{DD}	3.0	3.3	3.6	V	(2), (4)	
VDD Current	Mosaic Pattern	I_{DD}	-	-	0.2	A	(3),(4)
VDD Power Consumption	Mosaic Pattern	P_{DD}	-	-	0.8	W	
Rush Current		I_{Rush}	-	-	1.5	A	(1),(4),(5)
Allowable Logic/LCD Drive Ripple Voltage		V_{VDD-RP}	-	-	200	mV	(4)
LED Power Supply							
LED Input Voltage	V_{LED}	5	12	21	V	(4),(6)	
LED Power Consumption	P_{LED}	-	-	2.4	W	(4),(6)	
LED Forward Voltage	V_F	-	-	3.1	V	(4)	
LED Forward Current	I_F	-	20	-	mA		
PWM Signal Voltage	High	V_{PWM}	2.2	-	3.6		V
	Low		0	-	0.6		
LED Enable Voltage	High	V_{LED_EN}	2.2	-	3.6		V
	Low		0	-	0.6		
Input PWM Frequency	F_{PWM}	200	-	1,000	Hz		
Duty Ratio	PWM	1	-	100	%		
LED Life Time	LT	15,000	-	-	Hours		(4)(7)

Note (1) Measure Condition

Figure 10 VDD Rising Time

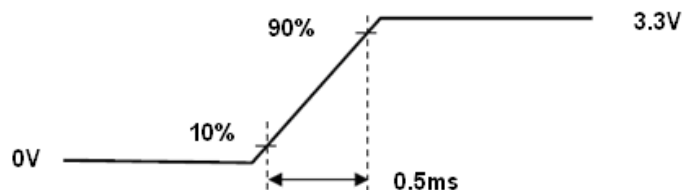

Note (2) VDD Power Dip Condition

$V_{TH} < V_{DD} \leq V_{min}$, $t_d \leq 10ms$ (a time of the voltage return to normal), our panel can revive

Document Title	M125NWR3 R0 Product Specification			Page No.	16/31
Document No.		Issue date	2015/06/19	Revision	01

automatically.

Figure 11 VDD Power Dip

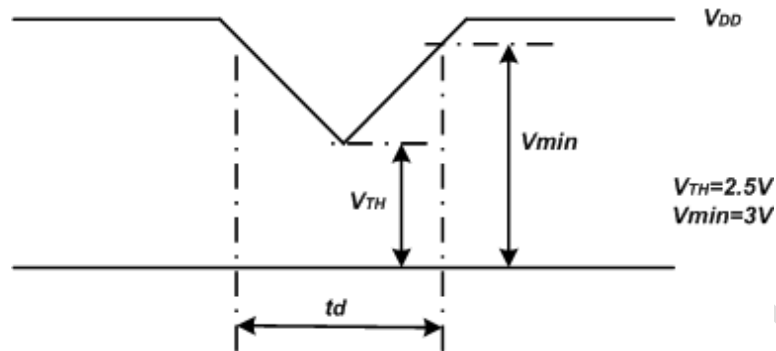

Note (3) Frame Rate=60Hz, VDD=3.3V, DC Current.

Note (4) Operating temperature 25°C, humidity 55%RH.

Note (5) The reference measurement circuit of rush current.

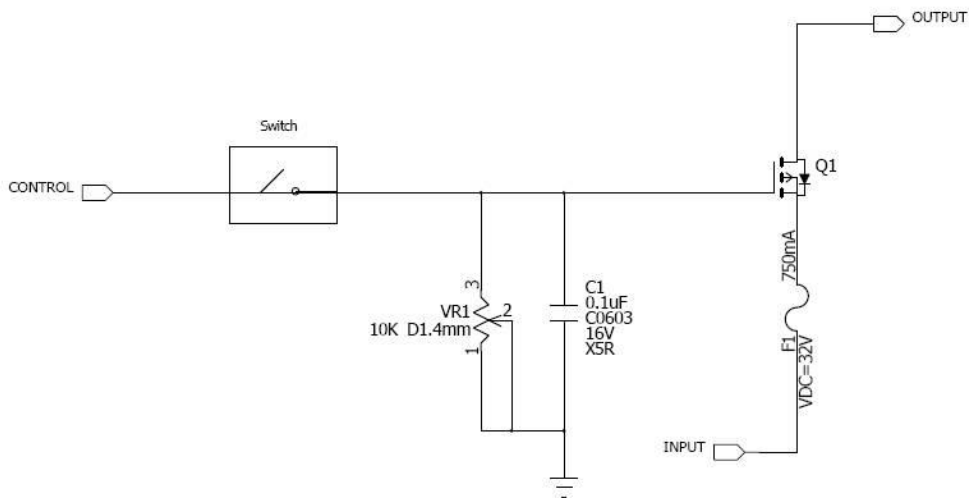

Note (7) The LED life time define as the estimated time to 50% degradation of initial luminous.

Document Title	M125NWR3 R0 Product Specification			Page No.	17/31
Document No.		Issue date	2015/06/19	Revision	01

4.5 Power ON/OFF Sequence

Interface signals are also shown in the chart. Signals from any system shall be Hi- resistance state or low level when VDD voltage is off.

Figure 12 Power Sequence

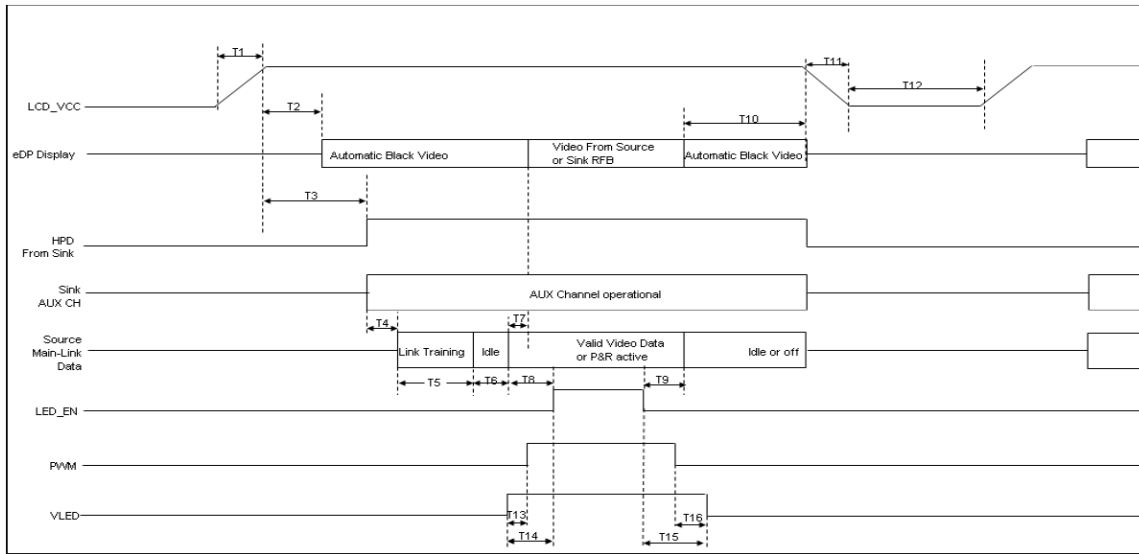

Table 10 Power Sequencing Requirements

Parameter	Symbol	Min.	Typ.	Max.	Unit
VCC Rise Time (10% to 90%)	T1	0.5	-	10	ms
Delay from VCC to automatic Black Video generation	T2	0	-	200	ms
Delay from VCC to HPD high	T3	0	-	200	ms
Delay from HPD high to link training initialization	T4	-	-	-	ms
Link training duration	T5	-	-	-	ms
Link idle	T6	-	-	-	ms
Delay from valid video data from Source to video on display	T7	0	-	50	ms
Delay from valid video data from Source to backlight enable	T8	200	-	-	ms
Delay from backlight disable to end of valid video date	T9	-	-	-	ms
Delay from end of valid video data from Source to VCC off	T10	0	-	500	ms
VCC fall time (90% to 10%)	T11	0	-	10	ms
VCC off time	T12	500	-	-	ms
Delay from VLED to PWM	T13	0	-	-	ms
Delay from VLED to backlight enable	T14	0	-	-	ms
Delay from backlight disable to VLED off	T15	0	-	-	ms
Delay from PWM off to VLED off	T16	0	-	-	ms

Document Title	M125NWR3 R0 Product Specification			Page No.	18/31
Document No.		Issue date	2015/06/19	Revision	01

5.0 Mechanical Characteristics

5.1 Outline Drawing

Figure 13 Reference Outline Drawing (Front Side)

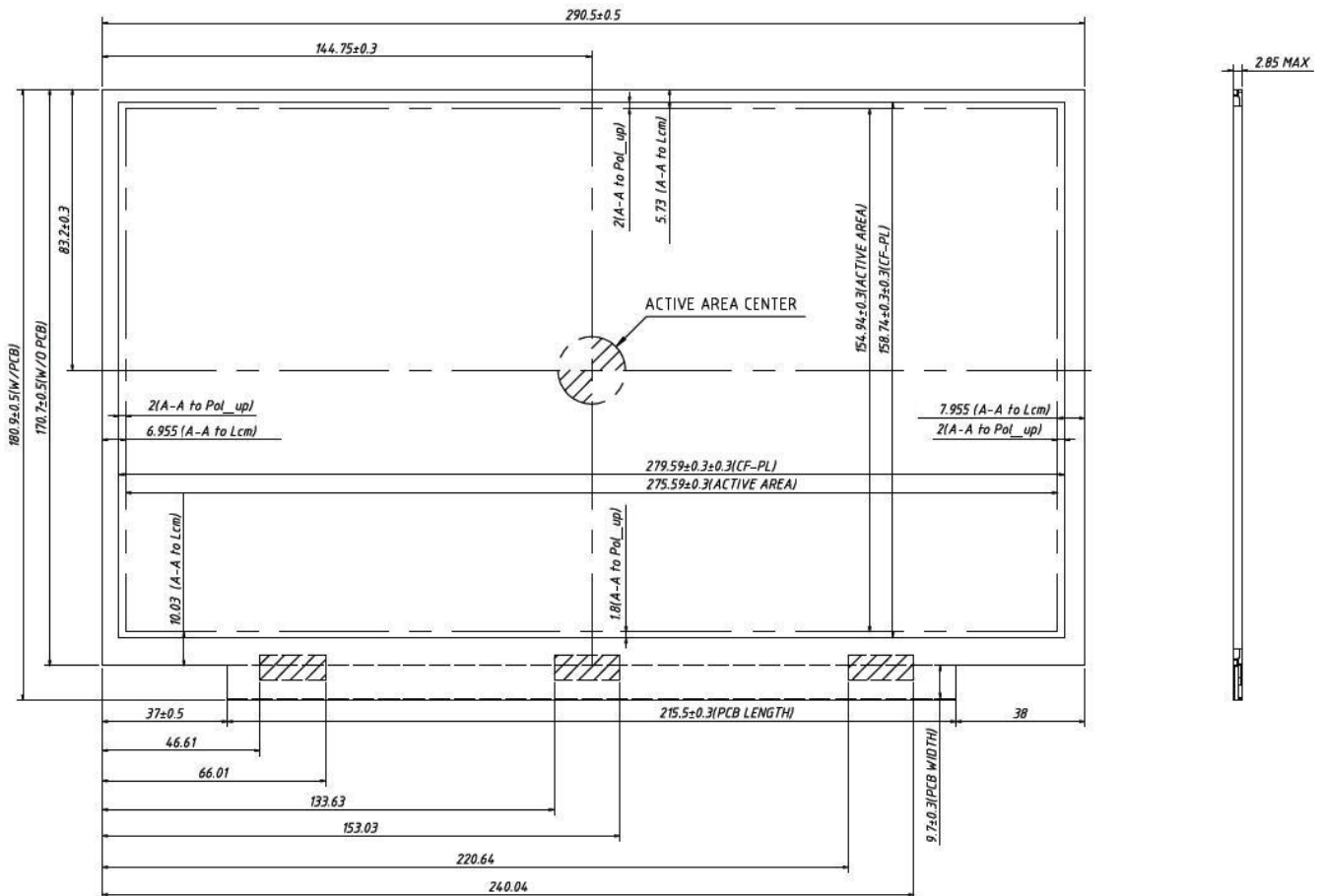

Notes:

1. PCB design: Bottom Flat PCBA layout is one side at PCBA rear area.
All the components are mounting on back side of PCB.
2. FPC area: FPC is in the hatching area of drawing(Have three FPC)
3. LCD highest portion must be Top Polarizer. And any other LCM materials must be lower than Top Polarizer
4. LCD Warpage $\leq \pm 0.5 \text{ mm}$

Document Title	M125NWR3 R0 Product Specification			Page No.	19/31
Document No.		Issue date	2015/06/19	Revision	01

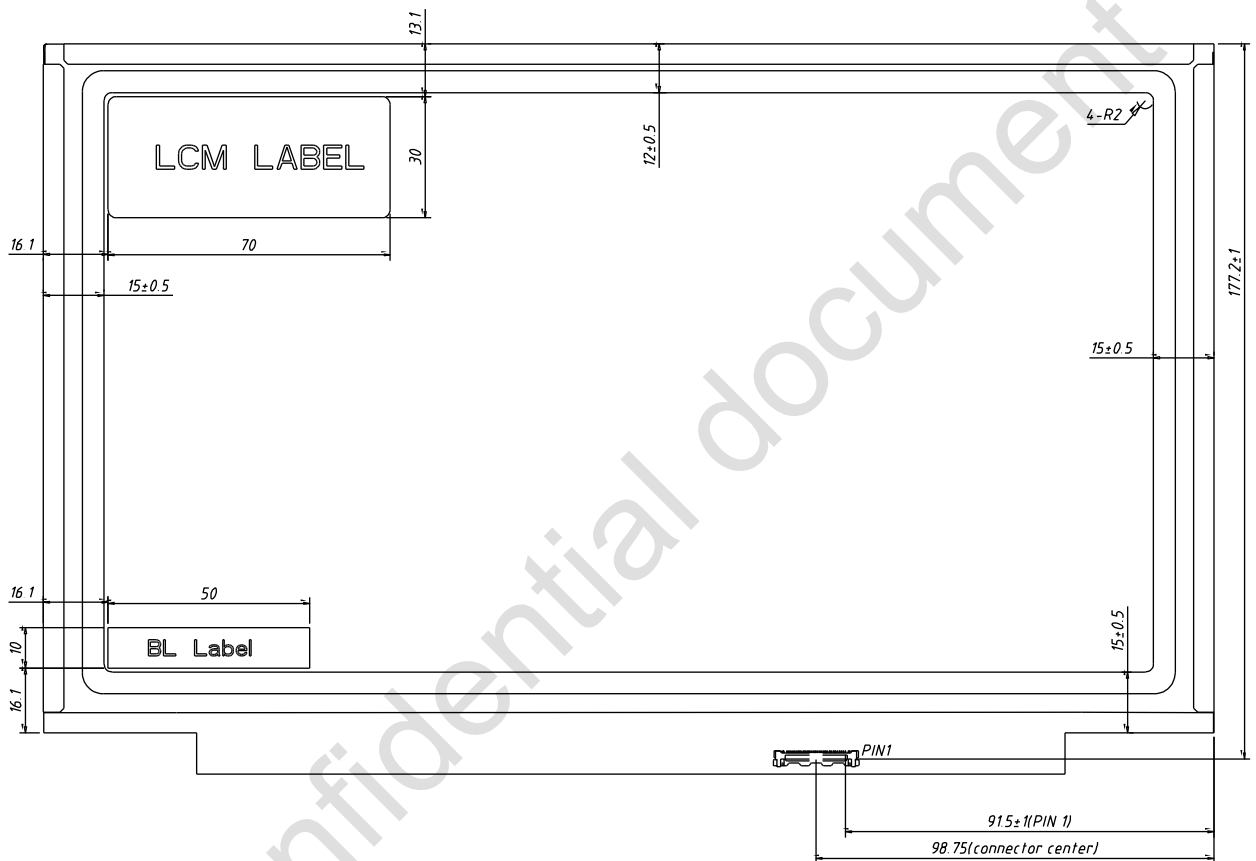
Figure 14 Reference Outline Drawing (Back Side)

5.2 Dimension Specifications

Table 11 Module Dimension Specifications

Item	Min.	Typ.	Max.	Unit
Width	290.0	290.5	291.0	mm
Height	180.4	180.9	181.4	mm
Thickness	-	-	2.85	mm
Weight	-	-	230	g



Document Title	M125NWR3 R0 Product Specification			Page No.	20/31
Document No.		Issue date	2015/06/19	Revision	01

6.0 Reliability Conditions

Item	Package	Test Conditions	Note
Low Temperature Operating Test	Module	0°C, 500 hours	(1),(2),(3),(4)
High Temperature Storage Test	Module	70°C, 240 hours	(1),(2),(4)
Low Temperature Storage Test	Module	-30°C, 240 hours	(1),(2),(4)
High Temperature Operating Test	Module	60°C, 500 hours	(1),(2),(3),(4)
High Temperature/High Humidity Operating Test	Module	50°C, 95%RH, 1000 hours	(1),(2),(3),(4)
Shock Non-operating Test	Module	210G, 3ms half-sine $\pm x \pm y \pm z$ each axis/1times 50G, 18msec Trapezoidal $\pm x \pm y \pm z$ each axis/1times	(4)
Vibration Non-operating Test	Module	1.5G , 10~200 Hz , x、 y、 z each axis/30min.	(4)
ESD Test	Operating	Module	(5)
		Contact	
		Air	± 15 KV, 150pF(330Ohm)

Note (1) All the judgments are under room temperature and the sample need to be static more than 2 hours in the room temperature before judge.

Note (2) During measurement, the condensation water or remains shall not be allowed.

Note (3) In operating test, the backlight voltage and current must be in specification.

Note (4) There is no display function issue occurred, all the cosmetic specification is judged before the reliability stress.

Note (5) In case of malfunction defect caused by ESD damage. If it would be recovered to normal state after resetting, it would be judge as pass.

Document Title	M125NWR3 R0 Product Specification			Page No.	21/31
Document No.		Issue date	2015/06/19	Revision	01

7.0 Package Specification

Figure 15 Packing Method

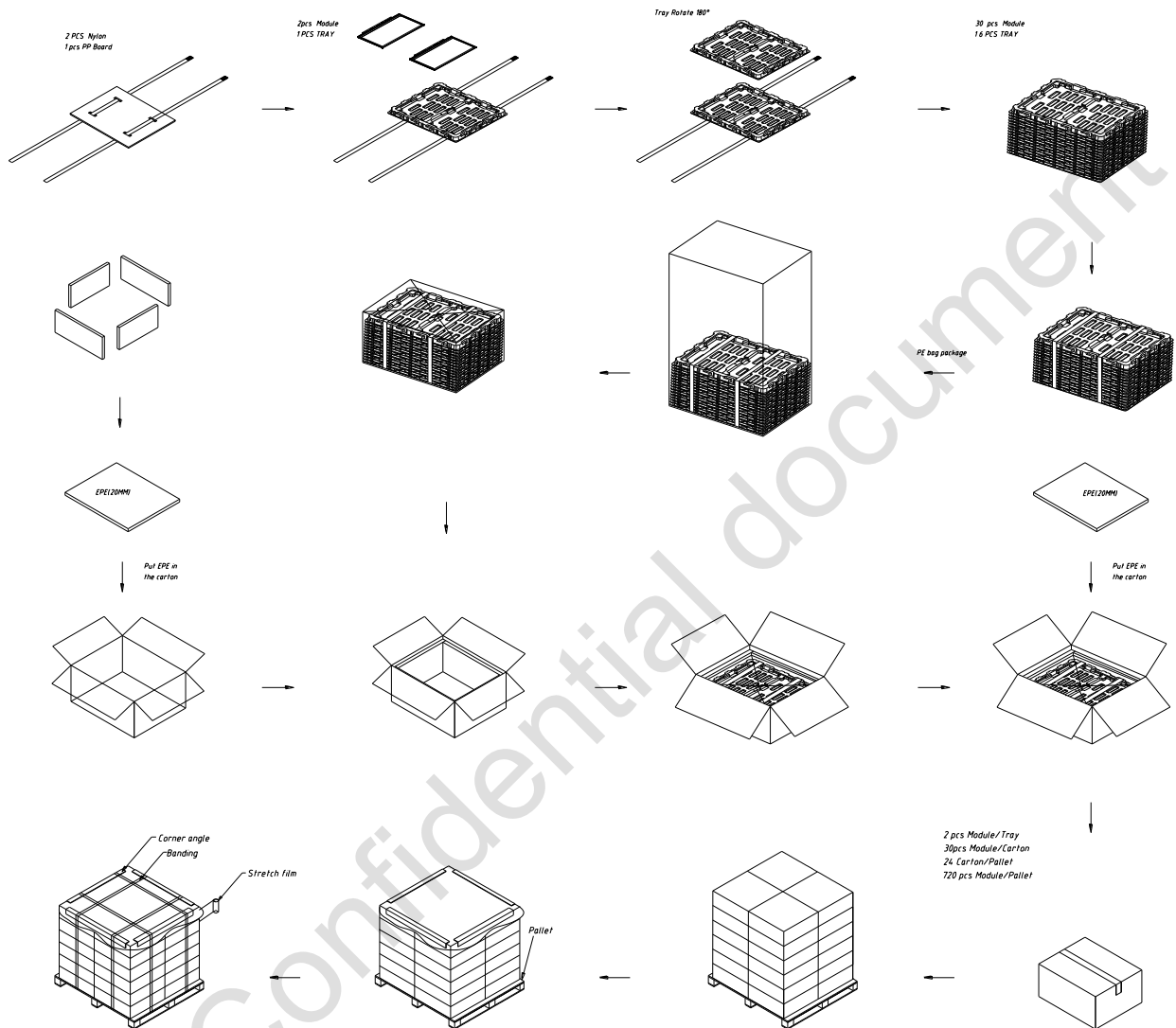

Document Title	M125NWR3 R0 Product Specification			Page No.	22/31
Document No.		Issue date	2015/06/19	Revision	01

8.0 Lot Mark



Note: This picture is only an example.

12.1 Lot Mark

1	2	3	4	5	6	7	8	9	10	11	12	13	14	15	16	17	18	19	20
---	---	---	---	---	---	---	---	---	----	----	----	----	----	----	----	----	----	----	----

- code 1,2,4,5,6,7,8,9,10,11,16: IVO internal flow control code.
- code 3: Production location.
- code 12: Production year.
- code 13: Production month.
- code 14,15: Production date.
- code 17,18,19,20: Serial number.

12.2 Customer code

Base on the requirement of customer.



Document Title	M125NWR3 R0 Product Specification			Page No.	23/31
Document No.		Issue date	2015/06/19	Revision	01

9.0 General Precaution

9.1 Use Restriction

This product is not authorized for use in life supporting systems, aircraft navigation control systems, military systems and any other application where performance failure could be life-threatening or otherwise catastrophic.

9.2 Handling Precaution

- (1) Please mount LCD module by using mounting holes arranged in four corners tightly.
- (2) Do not disassemble or modify the module. It may damage sensitive parts inside LCD module, and may cause scratches or dust on the display. IVO does not warrant the module, if customers disassemble or modify the module.
- (3) If LCD panel is broken and liquid crystal spills out, do not ingest or inhale liquid crystal, and do not contact liquid crystal with skin. If liquid crystal contacts mouth or eyes, rinse out with water immediately. If liquid crystal contacts skin or cloths, wash it off immediately with alcohol and rinse thoroughly with water.
- (4) Disconnect power supply before handling LCD module.
- (5) Refrain from strong mechanical shock and /or any force to the module.
- (6) Do not exceed the absolute maximum rating values, such as the supply voltage variation, input voltage variation, variation in parts parameters, environmental temperature; etc otherwise LCD module may be damaged. It's recommended employing protection circuit for power supply.
- (7) Do not touch, push or rub the polarizer with anything harder than HB pencil lead. Use fingerstalls of soft gloves in order to keep clean display quality, when persons handle the LCD module for incoming inspection or assembly.
- (8) When the surface is dusty, please wipe gently with absorbent cotton or other soft material. When cleaning the adhesives, please use absorbent cotton wetted with a little petroleum benzene or other adequate solvent.
- (9) Wipe off saliva or water drops as soon as possible. If saliva or water drops contact with polarizer for a long time, they may causes deformation or color fading.
- (10) Protection film must remove very slowly from the surface of LCD module to prevent from electrostatic occurrence.
- (11) Because LCD module uses CMOS-IC on circuit board and TFT-LCD panel, it is very weak to electrostatic discharge, please be careful with electrostatic discharge. Persons who handle the module should be grounded through adequate methods.
- (12) Do not adjust the variable resistor located on the module.

9.3 Storage Precaution

- (1) Please do not leave LCD module in the environment of high humidity and high temperature for a long time.
- (2) The module shall not be exposed under strong light such as direct sunlight. Otherwise, display characteristics may be changed.
- (3) The module should be stored in a dark place. It is prohibited to apply sunlight or fluorescent light in storage.

9.4 Operation Precaution

- (1) Do not connect or disconnect the module in the "Power On" condition.
- (2) Power supply should always be turned on/off by "Power On/Off Sequence".
- (3) Module has high frequency circuits. Sufficient suppression to the electromagnetic interference should be done by system manufacturers. Grounding and shielding methods may be important to minimize the interference.



Document Title	M125NWR3 R0 Product Specification			Page No.	24/31
Document No.		Issue date	2015/06/19	Revision	01

(4) After installation of the TFT module into an enclosure, do not twist nor bend the TFT module even momentary. At designing the enclosure, it should be taken into consideration that no bending/twisting forces are applied to the TFT module from outside. Otherwise the TFT module may be damaged.

9.5 Others

- (1) Ultra-violet ray filter is necessary for outdoor operation.
- (2) Avoid condensation of water which may result in improper operation or disconnection of electrode.
- (3) If the module keeps displaying the same pattern for a long period of time, the image may be "sticked" to the screen.
- (4) This module has its circuitry PCB's on the rear side and should be handled carefully in order not to be stressed.

9.6 Disposal

When disposing LCD module, obey the local environmental regulations.



Document Title	M125NWR3 R0 Product Specification			Page No.	25/31
Document No.		Issue date	2015/06/19	Revision	01

10.0 EDID Table Format

EDID Table Format					
Address (DEC)	Address (HEX)	Field Name & Comments	Value (HEX)	Value (BIN)	Value (DEC)
0	0	Header	00	00000000	0
1	1	Header	FF	11111111	255
2	2	Header	FF	11111111	255
3	3	Header	FF	11111111	255
4	4	Header	FF	11111111	255
5	5	Header	FF	11111111	255
6	6	Header	FF	11111111	255
7	7	Header	00	00000000	0
8	8	manufacture code	26	00100110	38
9	9	manufacture code	CF	11001111	207
10	A	Product Code	E5	11100101	229
11	B	Product Code	04	00000100	4
12	C	LCD module Serial No - ("0" if not used)	00	00000000	0
13	D	LCD module Serial No - ("0" if not used)	00	00000000	0
14	E	LCD module Serial No - ("0" if not used)	00	00000000	0
15	F	LCD module Serial No - ("0" if not used)	00	00000000	0
16	10	Week of manufacture	00	00000000	0
17	11	Year of manufacture	18	00011000	24
18	12	EDID Structure Ver # = 1	01	00000001	1
19	13	EDID revision # = 3	04	00000100	4
20	14	Video I/P definition = Digital I/P (80h)	95	10010101	149
21	15	Max H image size = (Rounded to cm)	1C	00011100	28
22	16	Max V image size = (Rounded to cm)	10	00010000	16



InfoVision Optoelectronics (Kunshan)Co., Ltd.

Document Title	M125NWR3 R0 Product Specification			Page No.	26/31
Document No.		Issue date	2015/06/19	Revision	01

23	17	Display Gamma	78	01111000	120
24	18	Feature support (no DPMS, Active off, RGB, timing BLK 1)	0A	00001010	10
25	19	Red/Green Low bits (RxRy/GxGy)	12	00010010	18
26	1A	Blue/White Low bits (BxBY/WxWy)	30	00110000	48
27	1B	Red X Rx	91	10010001	145
28	1C	Red Y Ry	56	01010110	86
29	1D	Green X Gx	53	01010011	83
30	1E	Green Y Gy	92	10010010	146
31	1F	Blue X Bx	28	00101000	40
32	20	Blue Y By	1E	00011110	30
33	21	White X Wx	50	01010000	80
34	22	White Y Wy	54	01010100	84
35	23	Established timings 1 (00h if not used)	00	00000000	0
36	24	Established timing 2 (00h if not used)	00	00000000	0
37	25	Manufacturer's timings (00h if not used)	00	00000000	0
38	26	Standard timing ID1 (01h if not used)	01	00000001	1
39	27	Standard timing ID1 (01h if not used)	01	00000001	1
40	28	Standard timing ID2 (01h if not used)	01	00000001	1
41	29	Standard timing ID2 (01h if not used)	01	00000001	1
42	2A	Standard timing ID3 (01h if not used)	01	00000001	1
43	2B	Standard timing ID3 (01h if not used)	01	00000001	1
44	2C	Standard timing ID4 (01h if not used)	01	00000001	1



InfoVision Optoelectronics (Kunshan)Co., Ltd.

Document Title	M125NWR3 R0 Product Specification			Page No.	27/31
Document No.		Issue date	2015/06/19	Revision	01

45	2D	Standard timing ID4 (01h if not used)	01	00000001	1
46	2E	Standard timing ID5 (01h if not used)	01	00000001	1
47	2F	Standard timing ID5 (01h if not used)	01	00000001	1
48	30	Standard timing ID6 (01h if not used)	01	00000001	1
49	31	Standard timing ID6 (01h if not used)	01	00000001	1
50	32	Standard timing ID7 (01h if not used)	01	00000001	1
51	33	Standard timing ID7 (01h if not used)	01	00000001	1
52	34	Standard timing ID8 (01h if not used)	01	00000001	1
53	35	Standard timing ID8 (01h if not used)	01	00000001	1
54	36	Pixel Clock LSB	20	00100000	32
55	37	Pixel Clock HSB	1C	00011100	28
56	38	Horizontal Active (lower 8 bits)	56	01010110	86
57	39	Hor blanking (lower 8 bits)	86	10000110	134
58	3A	Horizontal Active/Horizontal blanking (upper4:4 bits)	50	01010000	80
59	3B	Vertical active(lower 8 bits)	00	00000000	0
60	3C	Vertical blanking(lower 8 bits)	20	00100000	32
61	3D	Vertical Active : Vertical Blanking (upper4:4 bits)	30	00110000	48
62	3E	Horizontal Sync Offset	08	00001000	8
63	3F	Horizontal Sync Pulse Width	08	00001000	8
64	40	Vertical Sync Offset , Sync Width	88	10001000	136
65	41	Horizontal Vertical Sync Offset/Width upper 2 bits	00	00000000	0
66	42	Horizontal Image Size	14	00010100	20



InfoVision Optoelectronics (Kunshan)Co., Ltd.

Document Title	M125NWR3 R0 Product Specification			Page No.	28/31
Document No.		Issue date	2015/06/19	Revision	01

67	43	Vertical image Size	9B	10011011	155
68	44	Horizontal Image Size / Vertical image size	10	00010000	16
69	45	Horizontal Border = (0 for Notebook LCD)	00	00000000	0
70	46	Vertical Border = (0 for Notebook LCD)	00	00000000	0
71	47	Non-interlaced, Normal, no stereo, Separate sync, H/V pol Negatives,	19	00011001	25
72	48	Timing Descriptor #2	80	10000000	128
73	49		16	00010110	22
74	4A		56	01010110	86
75	4B		86	10000110	134
76	4C		50	01010000	80
77	4D		00	00000000	0
78	4E		20	00100000	32
79	4F		30	00110000	48
80	50		08	00001000	8
81	51		08	00001000	8
82	52		88	10001000	136
83	53		00	00000000	0
84	54		14	00010100	20
85	55		9B	10011011	155
86	56		10	00010000	16
87	57		00	00000000	0
88	58		00	00000000	0
89	59		19	00011001	25
90	5A	Detailed timing/monitor descriptor#3	00	00000000	0
91	5B	Flag	00	00000000	0
92	5C	Flag	00	00000000	0



InfoVision Optoelectronics (Kunshan)Co., Ltd.

Document Title	M125NWR3 R0 Product Specification			Page No.	29/31
Document No.		Issue date	2015/06/19	Revision	01

93	5D	Range limits	FE	11111110	254
94	5E	Flag	00	00000000	0
95	5F	Min. Vertical Freq	49	01001001	73
96	60	Max. Vertical Freq	6E	01101110	110
97	61	Min. Horizontal Freq	66	01100110	102
98	62	Max. Horizontal Freq	6F	01101111	111
99	63	Max. Pixel Clock Freq	56	01010110	86
100	64		69	01101001	105
101	65		73	01110011	115
102	66		69	01101001	105
103	67		6F	01101111	111
104	68		6E	01101110	110
105	69	New line character indicates end of ASCII string	0A	00001010	10
106	6A		20	00100000	32
107	6B		20	00100000	32
108	6C	Detailed timing/monitor descriptor #4	00	00000000	0
109	6D		00	00000000	0
110	6E		00	00000000	0
111	6F	FE (hex) defines ASCII string	FE	11111110	254
112	70	Flag	00	00000000	0
113	71	Manufacture P/N	4D	01001101	77
114	72	Manufacture P/N	31	00110001	49
115	73	Manufacture P/N	32	00110010	50
116	74	Manufacture P/N	35	00110101	53
117	75	Manufacture P/N	4E	01001110	78
118	76	Manufacture P/N	57	01010111	87
119	77	Manufacture P/N	52	01010010	82
120	78	Manufacture P/N	33	00110011	51
121	79	Manufacture P/N	20	00100000	32



InfoVision Optoelectronics (Kunshan)Co., Ltd.

Document Title	M125NWR3 R0 Product Specification			Page No.	30/31
Document No.		Issue date	2015/06/19	Revision	01

122	7A	Manufacture P/N	52	01010010	82
123	7B	Manufacture P/N	30	00110000	48
124	7C	New line character indicates end of ASCII string	20	00100000	32
125	7D		0A	00001010	10
126	7E	Extension Flag = 00	00	00000000	0
127	7F	Checksum	F1	11110001	241

IVO Confidential document