



Document Title	M121MNS1 R1 Product Specification			Page No.	1/26
Document No.		Issue date	2012/10/9	Revision	00

Product Specification

To: 苏州与来视讯科技有限公司

Product Name: M121MNS1 R1

Document Issue Date: 2012/10/9

Customer
<u>SIGNATURE</u>

Please return 1 copy for your confirmation with your signature and comments.

InfoVision Optoelectronics
<u>SIGNATURE</u>
REVIEWED BY

PREPARED BY

- Note:
1. Please contact InfoVision Company. before designing your product based on this product.
 2. The information contained herein is presented merely to indicate the characteristics and performance of our products.



InfoVision Optoelectronics (Kunshan) Co.,LTD.

Document Title	M121MNS1 R1 Product Specification			Page No.	2/26
Document No.		Issue date	2012/10/9	Revision	00

Revision	Date	Page	Old Description	New Description	Remark
00	2012/10/9	all	-	First issue.	

All rights strictly reserved reproduction or issue to third parties in any form what ever is not permitted without written authority from the proprietor.



Document Title	M121MNS1 R1 Product Specification			Page No.	3/26
Document No.		Issue date	2012/10/9	Revision	00

Contents

1.0	General Descriptions	4
2.0	Absolute Maximum Ratings	6
3.0	Pixel Format Image	7
4.0	Optical Characteristics	8
5.0	Backlight Characteristics	11
6.0	Electrical Characteristics	13
7.0	Interface Timings	16
8.0	Power Consumption	17
9.0	Mechanical Characteristics	19
10.0	Reliability	22
11.0	Package Specification	23
12.0	Lot Mark	24
13.0	General Precaution	25



Document Title	M121MNS1 R1 Product Specification			Page No.	4/26
Document No.		Issue date	2012/10/9	Revision	00

1.0 General Descriptions

1.1 Introduction

The M121MNS2 R0 is a color active matrix thin film transistor (TFT) liquid crystal display (LCD) that uses amorphous silicon TFT as a switching device. It is composed of a TFT LCD panel, a timing controller, voltage reference, common voltage, column driver, and row driver circuit. This TFT LCD has a 12.1-inch diagonally measured active display area with resolution (800 horizontal by 600 vertical pixel array).

1.2 Features

- 12.1" TFT LCD Panel
- LED Backlight System
- Supported (800x600 pixels) resolution
- Aspect ratio: 4:3
- Compatible with RoHS standard

1.3 Product Summary

Items	Specifications	Unit
Screen Diagonal	31(12.1inch)Diagonal	cm
Active Area	246.0 (H) x184.5 (V)	mm
Pixel format	800(H) x600(V) (1 pixel=R+G+B dot)	pixel
Pixel Pitch	0.3075(H)x0.3075(V)	mm
Pixel Arrangement	R.G.B. Vertical Stripe	-
Display Mode	Normally White	-
White Luminance	350(Min),450(Typ)	cd /m ²
Contrast Ratio	500(Min),800(Typ)	-
Response Time	30typ	msec
Input Voltage	3.3V(Logic),12V(LED)	V
Weight	700 Max	g
Unit outline dimensions(*1)	276.0(W)x209.0(H)x9.1(D)	mm
Electrical Interface (Logic)	LVDS	-
Support Color	262K colors(RGB 6 bit)	-
Surface Treatment	Anti-Glare and hard-coating 3H	-

(*1) excluding the area of the connector cover

Document Title	M121MNS1 R1 Product Specification			Page No.	5/26
Document No.		Issue date	2012/10/9	Revision	00

1.4 Functional Block Diagram

The functional block diagram of the LCD module.

Figure 1 Block Diagram

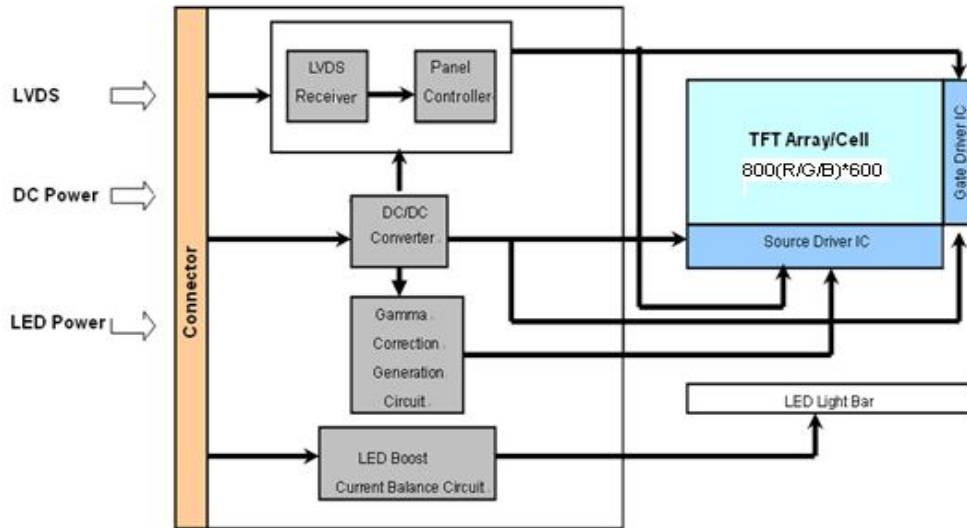



Document Title	M121MNS1 R1 Product Specification			Page No.	6/26
Document No.		Issue date	2012/10/9	Revision	00

2.0 Absolute Maximum Ratings

Table 1 Absolute Ratings of Environment

Item	Symbol	Condition	Pin	Ratings	Unit	Remark
Supply Voltage	V _{CC}	Ta=25℃	VCC	-0.3~+4.0	V	Note1,2
	V _{DD}	Ta=25℃	VDD	-0.3~+15.0	V	Note1,2
Input voltage	V _{I1}	Ta=25℃	RxINi-/+ CK IN-/+	-0.3~V _{CC} +0.3	V	I=0,1,2
	V _{I2}	Ta=25℃	RL/UD	-0.3~ V _{CC} +0.3	V	
	V _{I4}	Ta=25℃	XSTABY,VBR	-0.3~ V _{DD}	V	
Storage temperature	T _{STG}	-	-	-30~+80	℃	Note1
Operating temperature	T _{OPA}	-	--	-20~+70	℃	Note1,3,4

Note1: Humidity: 95%RH Max. (Ta<=40℃) Note static electricity.

Maximum wet-bulb temperature at 39℃ or less.(Ta>40℃) No condensation.

Note2: The V_{CC} power supply capacity must use the one of 2A or more.

The V_{DD} power supply capacity must use the one of 3A or more.

Note3: There is a possibility of causing deterioration in the irregularity and others of the screen and the display fineness though the liquid crystal module doesn't arrive at destruction when using it at 65~70℃. There is a possibility of causing the fineness deterioration by the prolonged use in the(high temperature) humidity environment(60% or more).

Note4: In the operating temperature item, the low temperature side is the ambient temperature regulations. The high temperature side is the panel surface temperature regulations.

Document Title	M121MNS1 R1 Product Specification			Page No.	7/26
Document No.		Issue date	2012/10/9	Revision	00

3.0 Pixel Format Image

Figure 2 shows the relationship of the input signals and LCD pixel format image.

Figure 2 Pixel Format

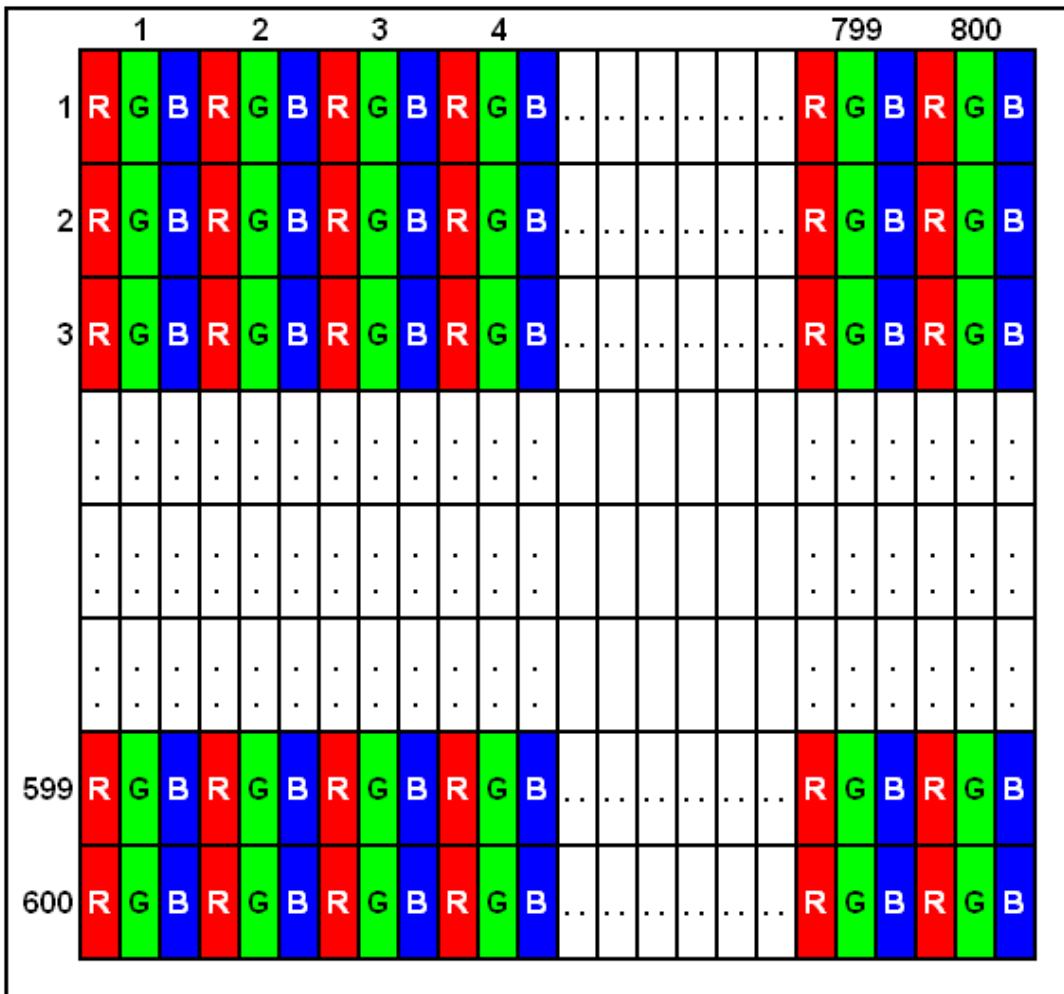



Document Title	M121MNS1 R1 Product Specification			Page No.	8/26
Document No.		Issue date	2012/10/9	Revision	00

4.0 Optical Characteristics

The optical characteristics are measured under stable conditions as following notes

Table 2 Optical Characteristics

Item	Condition		Specification			
			Min.	Typ.	Max.	Note
Viewing Angle [degrees] K=Contrast Ratio>10	Horizontal	θ_L	70	80	-	A, B,D
		θ_R	70	80	-	
	Vertical	θ_T	50	60	-	
		θ_B	70	80	-	
Contrast Ratio	Center		500	800	-	B,D
Response time	Tr		-	7	-	C,D
	Tf		-	23	-	
	Tr + Tf		-	30	-	
Color Chromaticity (CIE 1,931)	Red	x	-0.03	0.580	+0.03	D
	Red	y		0.330		
	Green	x		0.325		
	Green	y		0.600		
	Blue	x		0.155		
	Blue	y		0.100		
	White	x	0.250	0.300	0.350	
	White	y	0.265	0.315	0.365	
White Luminance [cd/m ²]	Center		350	450	-	D
White Uniformity [%]	5Points		75	-	-	E

*The measurement shall be executed 30 minutes after lighting at rating.

The optical characteristics shall be measured in a dark room or equivalent state with the method shown in below.

Document Title	M121MNS1 R1 Product Specification			Page No.	9/26
Document No.		Issue date	2012/10/9	Revision	00

Figure 3 Measurement Setup

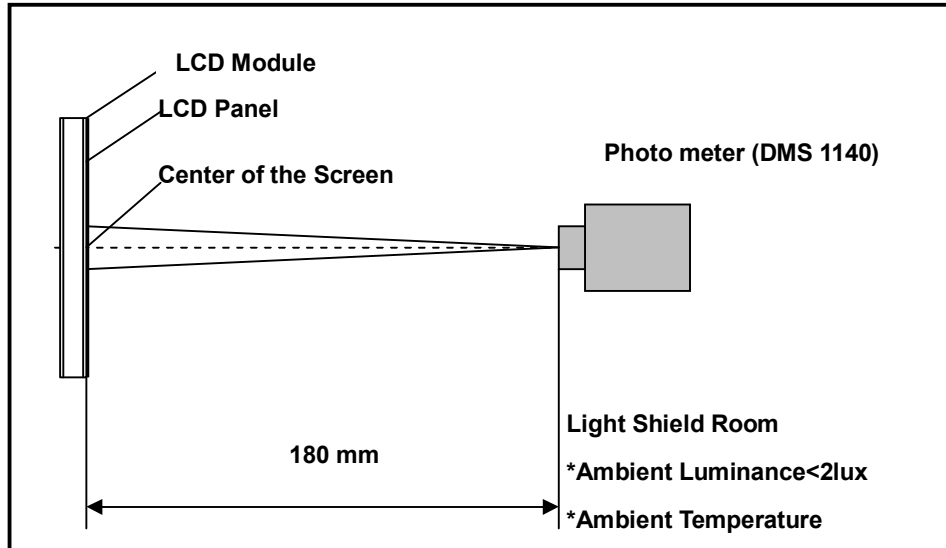

Note A: Definitions of viewing angle range

Figure 4 Definition of Viewing Angle

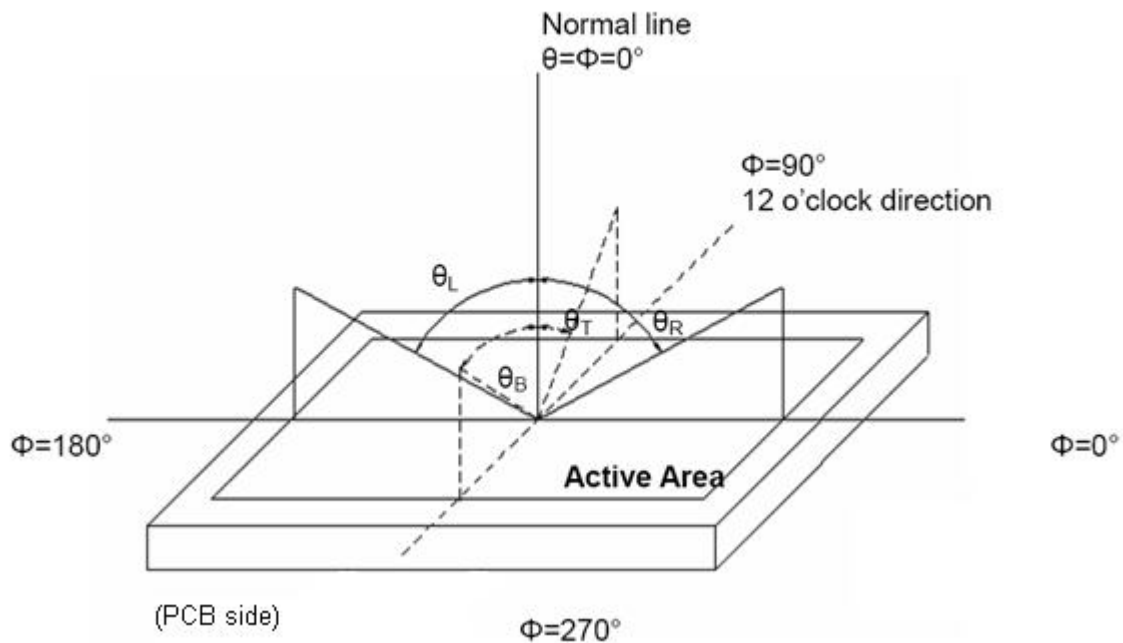

Note B: Definition Of Contrast Ratio (CR)

The contrast ratio is defined as the following

Contrast Ratio (CR) = Luminance with all pixels white / Luminance with all pixels black

Note C: Definition Of Response Time (T_R , T_F)

The response time is defined as the following figure and shall be measured by switching the input signal for “black” and “white”

Document Title	M121MNS1 R1 Product Specification			Page No.	10/26
Document No.		Issue date	2012/10/9	Revision	00

Figure 5 Definition of Response Time

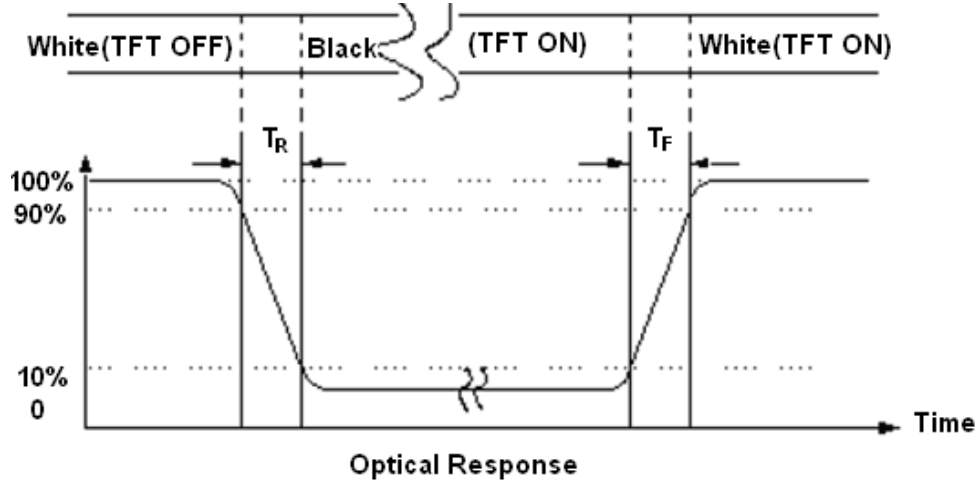

Note D: This shall be measured at center of the screen.

Note E: Definition Of white uniformity

White uniformity is defined as the following with five measurements

$$\text{Luminance uniformity} = \frac{(\text{Min Luminance of 5 points})}{(\text{Max Luminance of 5 points})} \times 100\%$$

Figure 6 Measurement Locations

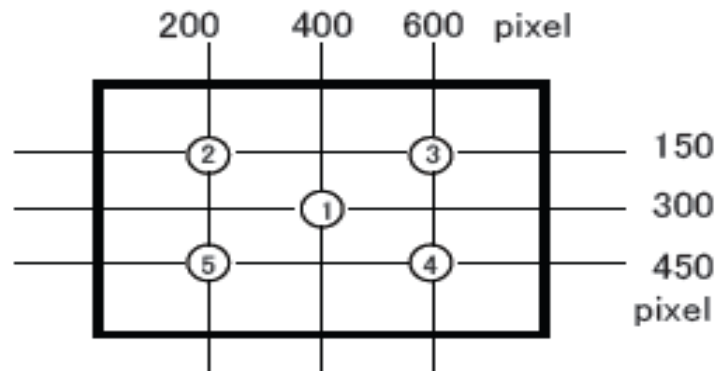

Document Title	M121MNS1 R1 Product Specification			Page No.	11/26
Document No.		Issue date	2012/10/9	Revision	00

5.0 Backlight Characteristics

5.1 Parameter Guideline Of LED Backlight

Table 3 Parameter Guideline for LED Backlight

Parameter	Symbol	Min	Typ.	Max.	Units	Condition	
Supply voltage	VDD	10.2	12	13.8	[V]	Note A	
Current dissipation	IDD	-	570	670	mA	Note B	
Permissive input ripple voltage	V _{RP_BL}	-	-	200	mVp-p	VDD=12V	
XSTABY	High voltage	V _{IH_BL1}	2.4	-	VDD	V	Note C
	Low voltage	V _{IL_BL1}	-	-	0.2	V	
PWM frequency	f _{PWM}	200	-	1K	Hz	Note D,E	
PWM duty	DPWM	10	-	100	%	Note D,E	
VBR	High voltage	V _{IH_BL2}	2.1	-	VDD	V	Note D
	Low voltage	V _{IL_BL2}	-	-	0.8	V	
Life Time	L	50,000	-	-	Hours	Note F	

Note A: On-off conditions for supply voltage

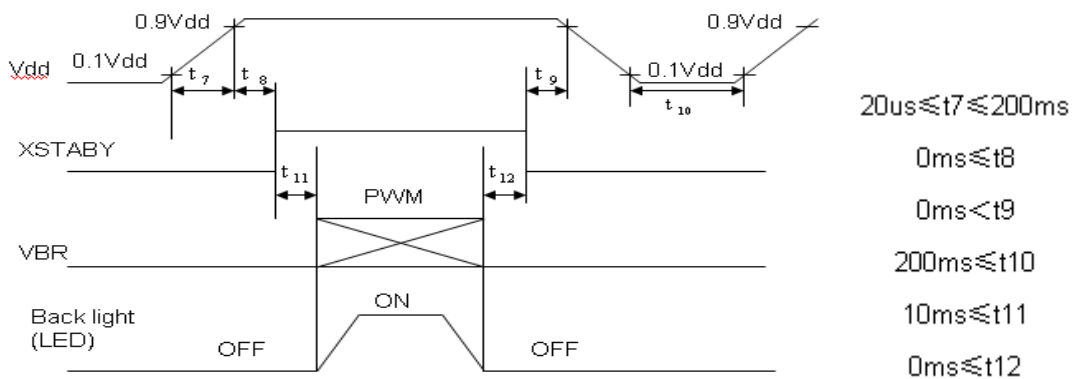

Note B: Current dissipation

Typ. Value: VDD=+12V, Duty=100%

Max. Value: VDD=10.2V, Duty=100%

Note C: Backlight ON/OFF signal(connected by the pull-down resistor of 10K Ω)

Note D: PWM signal(connected by the pull-down resistor of 10K Ω)

Document Title	M121MNS1 R1 Product Specification			Page No.	12/26
Document No.		Issue date	2012/10/9	Revision	00

Note E: PWM

$$F_{PWM} = 1/t_{14}$$

Duty 10%: Min. Luminance(0%:LED OFF)

Duty 100%: Max. Luminance

Luminance changes in proportion to the duty ratio.($t_{13} \geq 10\mu s$)

When the frequency slows, the display fineness might decrease.

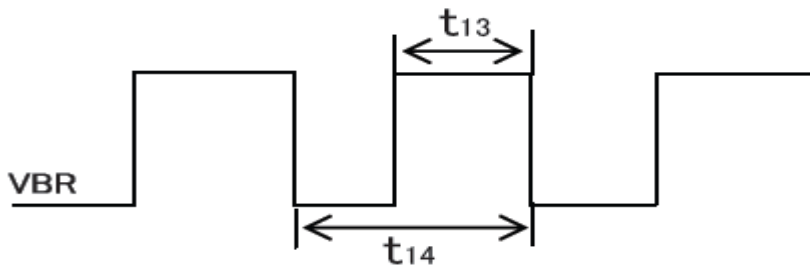

Note F: Luminance becomes 50% of an initial value. ($T_a=25^{\circ}C, PWM=100%$)



Document Title	M121MNS1 R1 Product Specification			Page No.	13/26
Document No.		Issue date	2012/10/9	Revision	00

6.0 Electrical Characteristics

6.1 TFT LCD panel driving

CN1(Interface signals and +3.3V power supply)

Using connectors: 076B20-0048RA-G4 (Starconn) or similar type.

Corresponding connectors:FI-SE20M or FI-S20S(Japan Aviation Electronics Industry Co., Ltd)

Table 4 Signal Pin Assignment

Pin #	Symbol	Function	Remarks
1	Vcc	+3.3V Power supply	-
2	Vcc	+3.3V Power supply	-
3	GND	GND	-
4	GND	GND	-
5	RxIN0-	LVDS receiver signal CH0(-)	LVDS
6	RxIN0+	LVDS receiver signal CH0(+)	LVDS
7	GND	GND	-
8	RxIN1-	LVDS receiver signal CH1(-)	LVDS
9	RxIN1+	LVDS receiver signal CH1(+)	LVDS
10	GND	GND	-
11	RxIN2-	LVDS receiver signal CH2(-)	LVDS
12	RxIN2+	LVDS receiver signal CH2(+)	LVDS
13	GND	GND	-
14	CK IN-	LVDS receiver signal CK(-)	LVDS
15	CK IN+	LVDS receiver signal CK(+)	LVDS
16	GND	GND	-
17	NC	Non connection	-
18	RL/UD		-
19	GND	GND	-
20	GND	GND	-

Document Title	M121MNS1 R1 Product Specification			Page No.	14/26
Document No.		Issue date	2012/10/9	Revision	00

6.1.1 RL/UD drawing

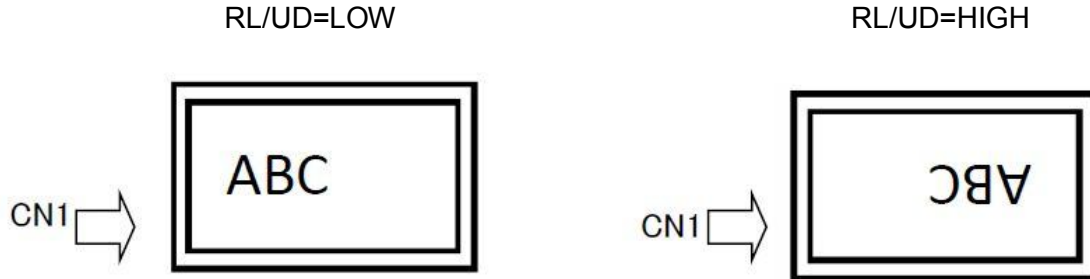

6.1.2 Signal Drawing

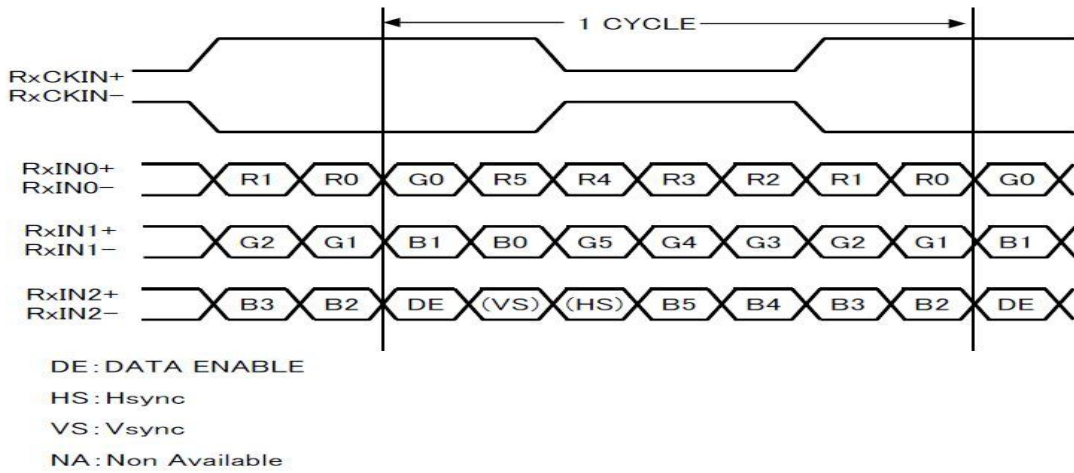

6.1.3 Interface block diagram

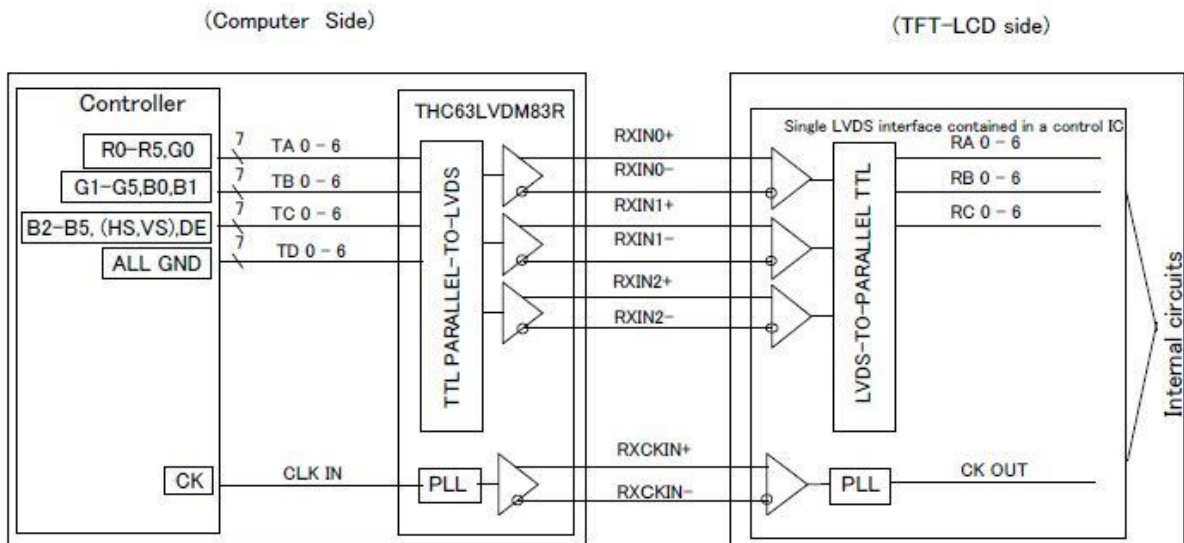



Document Title	M121MNS1 R1 Product Specification			Page No.	15/26
Document No.		Issue date	2012/10/9	Revision	00

6.2 LED backlight connector

CN2 Used connector: SM06B-SHLS-TF(J.S.T.Mfg.Co.Ltd)
or Similar type

Corresponding connector: SHLP-06V-S-B

Table 5 LED Power Pin Assignment

Pin #	Symbol	Function
1	VDD	+12V Power supply
2	VDD	+12V Power supply
3	GND	GND
4	GND	GND
5	XSTABY	LED ENABLE PIN
6	VBR	SYSTEM PWM SIGNAL INPUT

Document Title	M121MNS1 R1 Product Specification			Page No.	16/26
Document No.		Issue date	2012/10/9	Revision	00

7.0 Interface Timings

7.1 Timing Characteristics

Table 6 Interface Timings

Parameter	Symbol	Min	Typ	Max	Unit
DCLK Frequency	1/Tc	35	40	42	MHz
Horizontal Display Area	thd	800			DCLK
H Total Time	th	940	1056	1395	DCLK
H Active Time		23.5	26.4	39.9	us
Vertical Display Area	tvd	600			Line
V Total Time	tv	628	666	798	line
V Active Time		-	16.7	-	ms

Note: In case of using the long vertical period, the deterioration of display quality, flicker etc. may occur.

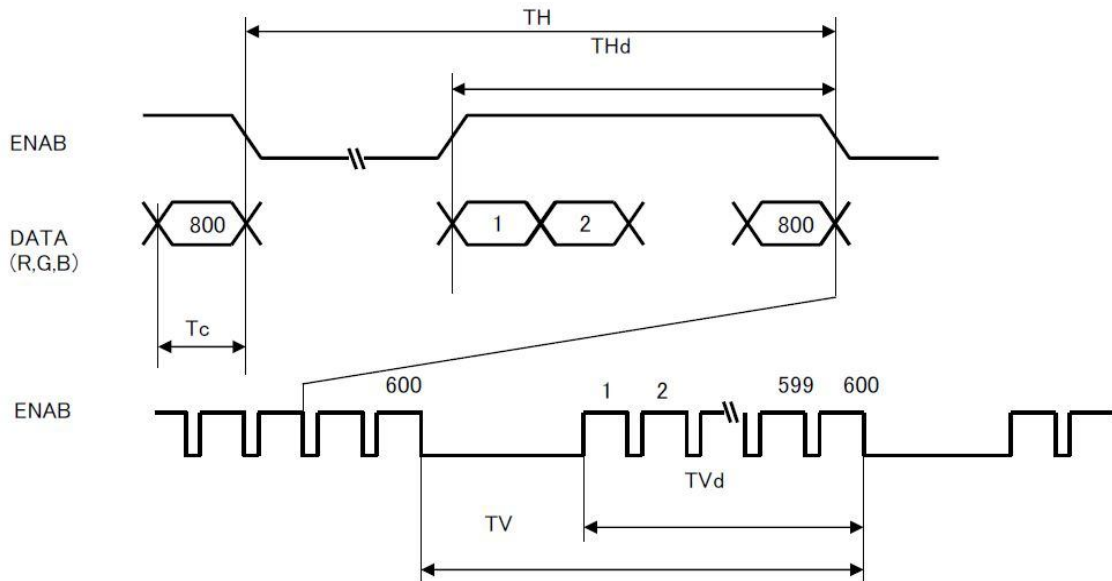

Document Title	M121MNS1 R1 Product Specification			Page No.	17/26
Document No.		Issue date	2012/10/9	Revision	00

8.0 Power Consumption

Input power specifications are as follows.

Table 7 Power Consumption

Parameter	Symbol	Condition	Min.	Typ.	Max.	Units	Condition
Supply voltage	V _{CC}		3.0	3.3	3.6	[V]	Note1
Current dissipation	I _{CC}	V _{CC} =3.3V	-	270	350	[mA]	Note2
Input voltage width for LVDS receiver	V _L		-	-	2.4	[V]	
Permissive input ripple voltage			-	-	200	mVp-p	V _{CC} =3.3V
Differential input Threshold voltage	High	V _{TH}	-	-	V _{cm} +100	mV	V _{cm} =1.2V Note3
	Low	V _{TL}	V _{cm} -100	-	-	mV	
Input voltage	V _{IH}		2.1	-	-	V	Note4
	V _{IL}		-	-	0.8	V	
Input reak current	I _{OH}		-	-	400	uA	V _{I2} =+3.3V, Note4
	I _{OL}		-10	-	+10	uA	V _{I2} =0V,Note4
Terminal resistor	R _T		-	100	-	Ω	Differential input

Note 1: On-off condition for supply voltage

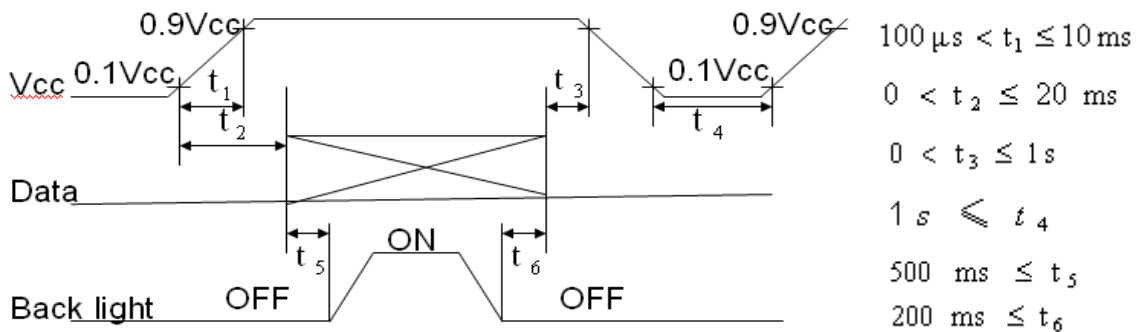

Document Title	M121MNS1 R1 Product Specification			Page No.	18/26
Document No.		Issue date	2012/10/9	Revision	00

Vcc-dip Condition

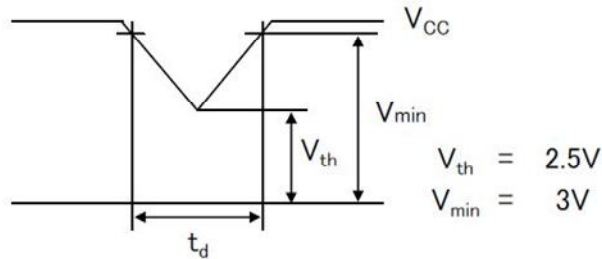

Figure 7 Vcc Power Dip

If $V_{TH} < V_{cc} \leq V_{min}$, then $t_d \leq 10ms$; When the voltage return to normal our panel must revive automatically.

If $V_{cc} < V_{th}$, then Vcc-dip conditions should also follow the On-off conditions for supply voltage. Hsync/Vsync need not be input so that this model may drive only by the ENAB signal. Even if Hsync/ Vsync is input, it doesn't become a malfunction. The relation between the data input and the backlight will recommend the above-mentioned input sequence. When the backlight is turned on before the panel operates, there is a possibility of abnormally displaying. The liquid crystal module is not damaged.

Note2: Current dissipation

Typical current situation: 64-gray-bar pattern ($V_{cc}=3.3V, f_{ck}=40MHz, T_a=25^\circ C$)

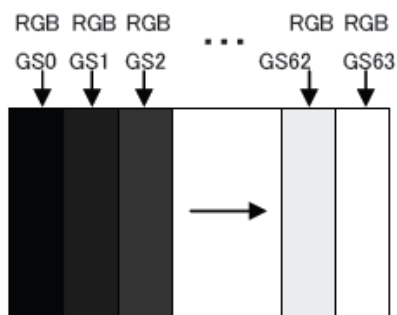

Note3: Vcm: LVDS Common mode voltage

Note4: RL/UD



Document Title	M121MNS1 R1 Product Specification	Page No.	19/26
Document No.		Issue date	2012/10/9
		Revision	00

9.0 Mechanical Characteristics

9.1 Outline Drawing

Figure 8 Outline Drawing (Front Side)

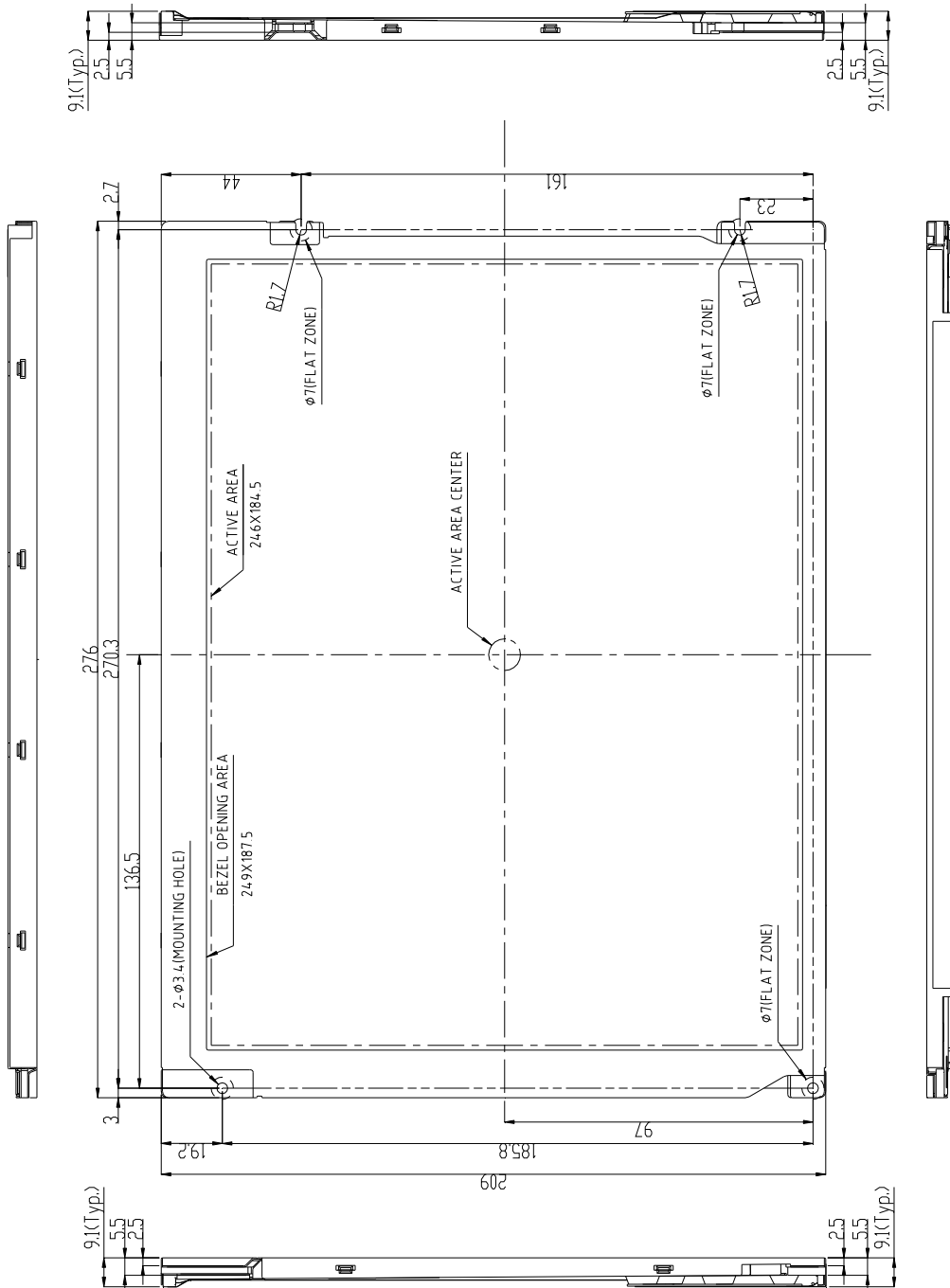

Document Title	M121MNS1 R1 Product Specification		Page No.	20/26	
Document No.		Issue date	2012/10/9	Revision	00

Figure 9 Outline Drawing (Back Side)

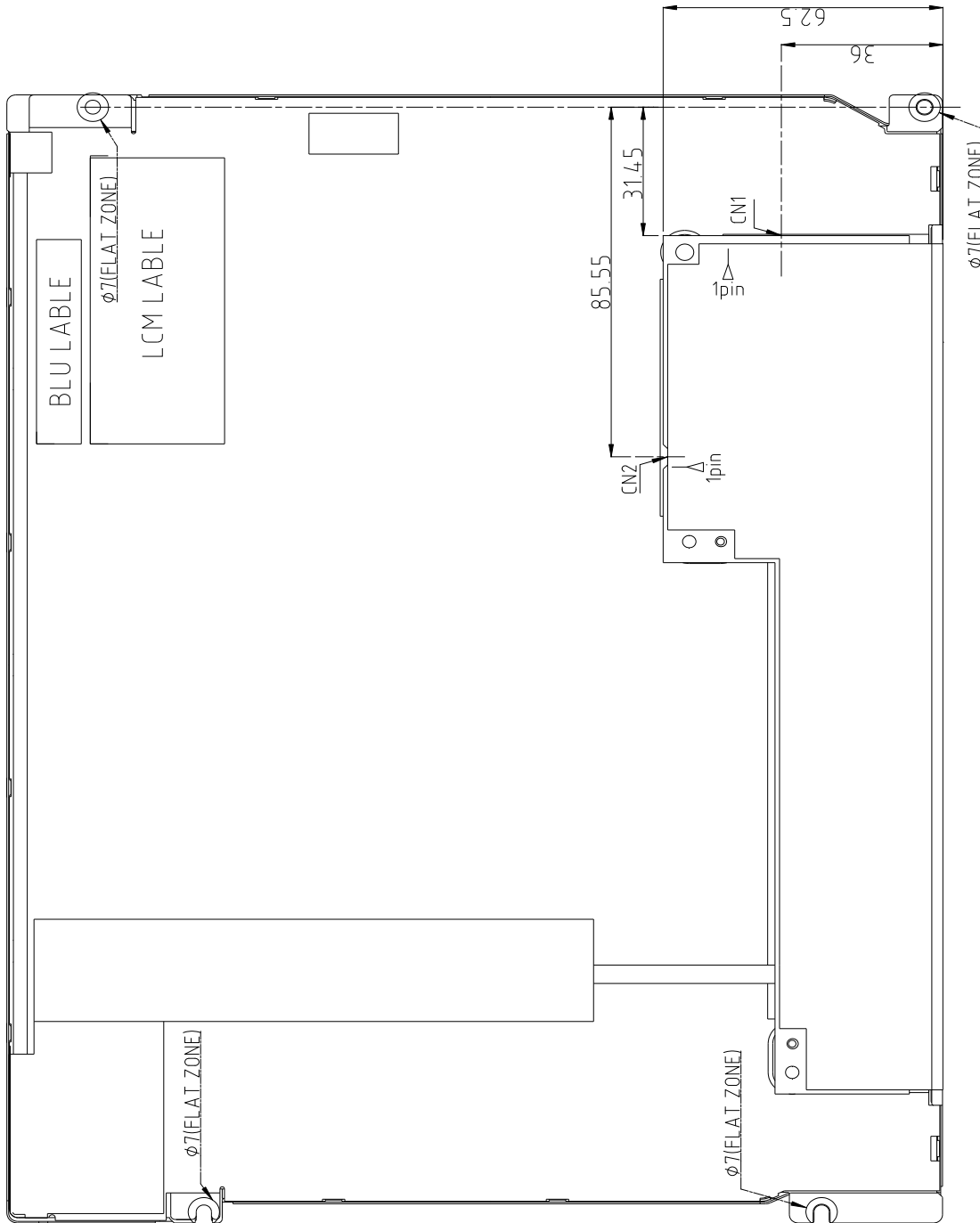

Note: Unspecified tolerance to be ±0.5mm

Document Title	M121MNS1 R1 Product Specification			Page No.	21/26
Document No.		Issue date	2012/10/9	Revision	00

9.2 Active area & Bezel opening drawing

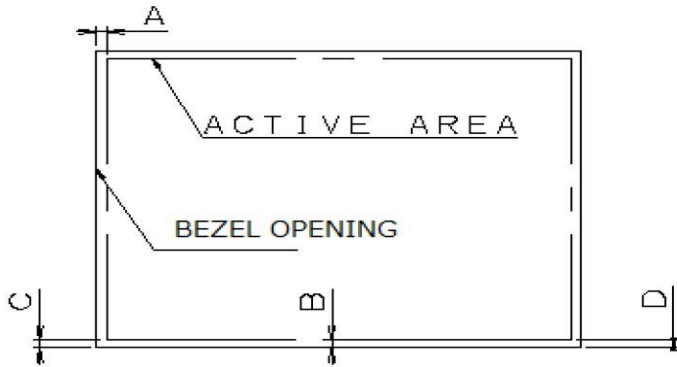

9.3.1. Tolerance x-direction A: 1.5 ± 0.5

9.3.2. Tolerance y-direction B: 1.5 ± 0.5

9.3.3. Obliquity of Display Area $|C-D| < 0.5$

9.3 Dimension Specifications

Table 8 Module Dimension Specifications

Width [mm]	276.0 ± 0.5
Height [mm]	209.0 ± 0.5
Thickness [mm]	9.1 ± 0.5
Weight [g]	700 Max
Unspecified tolerance to be $\pm 0.5\text{mm}$	



Document Title	M121MNS1 R1 Product Specification			Page No.	22/26
Document No.		Issue date	2012/10/9	Revision	00

10.0 Reliability

Item	Package	Test Conditions	Conditions
High Temperature Storage Test	Module	Ambient temperature 80°C,500H	Note1
Low Temperature Storage Test	Module	Ambient temperature -30°C, 500hrs	Note1
High Temp./High Humidity Storage Test	Module	Ambient temperature 50°C, Humidity 95%, 500hrs (No condensation)	Note1
High Temperature Operation Test	Module	Panel surface 70°C, 500hrs	Note1
Low Temperature Operating Test	Module	Ambient temperature -20°C, 500hrs	Note1
High Temp./High Humidity Operation Test	Module	Ambient temperature 50°C, Humidity 85%, 500hrs (No condensation)	Note1
Image Sticking Test	Module	Ambient temperature 25°C, 24H	Note1
Thermal shock test	Module	-30°C~80°C, 1hr/each cycle, 200cycles	Note1
Altitude Test	Module	40°C, 55kPa, 300H, Altitude Site level to 16K feet	Note1
Pressure Test	Module	3kg/60sec	Note1
ESD Test	Module	Operating Contact ±8kV Operating Air ±15kV Non-Operating Contact ±10kV Non-Operating Contact ±20kV	Note1
Vibration Test	Module	1.5 G,10~500Hz, x, y, z each axis/1 h	Note1
Shock Test	Module	Half Sine Wave 70G 11ms, ±X,±Y,±Z 1 times each axis	Note1
Vibration Test (no-operating)	With package	1.5 G,10~500Hz, x, y, z each axis/1 h	Note1
Drop Test		65cm, 1 corner, 3arris, 6side	Note1
<p>Note1: Under the display quality test conditions with normal operation state, these shall be no change which may affect practical display function.(normal operation state:Temperature:15~35°C, Humidity:45~75%, Atmospheric pressure:86~106kpa)</p>			

Document Title	M121MNS1 R1 Product Specification			Page No.	23/26
Document No.		Issue date	2012/10/9	Revision	00

11.0 Package Specification

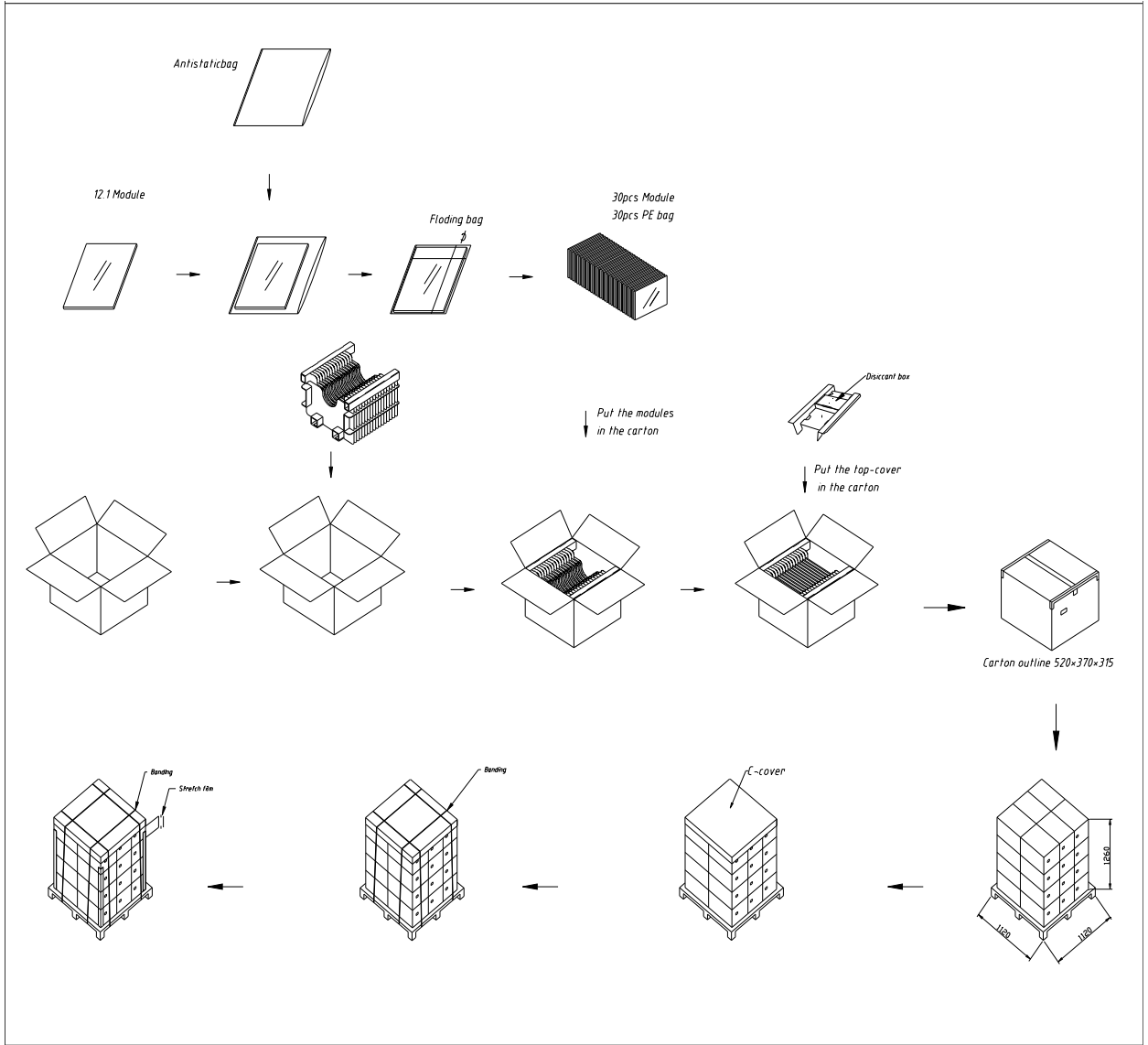

Components Material	Carton	PE Bag	Module	Protect film	Weight		
Material Size(mm)	520*370*315	295*260*0.06	276*209*9.1	254*194*0.08	675g/pcs module(typ) 700g/pcs module(max)	23Kg/Carton(typ) 25.5Kg/Carton(max)	575Kg/Pallet(typ) 633Kg/Pallet(max)
Amount	1Pcs/Carton	30pcs/Carton	30pcs/Carton	30pcs/Carton	1Pcs Module	30Pcs Module (include packing)	720Pcs Module (include packing)

Piling number of cartons: Max 6

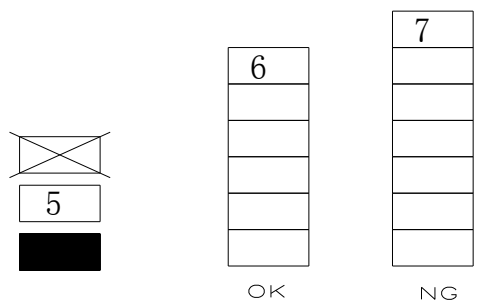



Document Title	M121MNS1 R1 Product Specification			Page No.	24/26
Document No.		Issue date	2012/10/9	Revision	00

12.0 Lot Mark

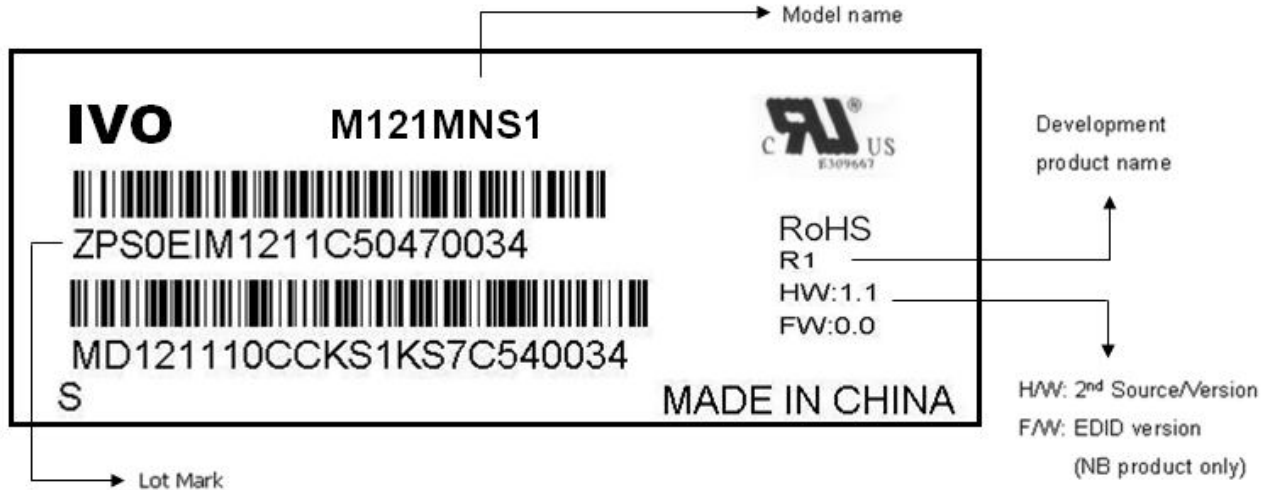

12.1 Lot mark

1	2	3	4	5	6	7	8	9	10	11	12	13	14	15	16	17	18	19	20
---	---	---	---	---	---	---	---	---	----	----	----	----	----	----	----	----	----	----	----

- Code 1: Production grade.
- Code 2: ME material collocation, as production P/N No.11 code.
- Code 3: define Module factory code.
- Code 4: IVO internal flow control code.
- Code 5: Production's BOM sort, EBOM and MBOM.
- Code 6: define Cell factory code.
- Code 7~11: Project code.
- Code 12~15: Production Year ,Month, Date.
- Code 16: Production line.
- Code 17~20: Serial Number.



Document Title	M121MNS1 R1 Product Specification			Page No.	25/26
Document No.		Issue date	2012/10/9	Revision	00

13.0 General Precaution

13.1 Use Restriction

In case of using the device for life supporting systems, aircraft navigation control systems, military systems and any other application where performance failure could be life-threatening or otherwise catastrophic, take into consideration that appropriate measures such as fail-safe functions and redundant system design should be taken.

13.2 Handling Precaution

- (1) Be sure to turn off the power supply when inserting or disconnecting the cable.
- (2) Since the front polarizer is easily damaged, pay attention not to scratch it.
- (3)Wipe off water drop immediately. Long contact with water may cause discoloration or spots.
- (4)When the panel surface is soiled, wipe it with absorbent cotton or other soft cloth.
- (5)Since the panel is made of glass, it may break or crack if dropped or bumped on hard surface. Handle with care.
- (6)Since CMOS LSI is used in this module, take care of static electricity and injure the human earth when handing. Observe all other precautionary requirements in handling components.
- (7)Since there is a circuit board in the module back, stress is not added at the time of a design assembly. Please make it like. If stress is added, there is a possibility that circuit parts may be damaged.
- (8)It causes an irregular display and the defective indication, etc., when always put constant pressure on the back of the module. Please do not make the structure to press the back of the module.
- (9) Do not expose the LCD panel to direct sunlight. Lightproof shade etc. should be attached when LCD panel is used under such environment.
- (10) Connect GND to stabilize against EMI and external noise.
- (11)When handling LCD modules and assembling them into cabinets, please avoid that long-terms storage in the environment of oxidization or deoxidization gas and the use of such materials as reagent, solvent, adhesive, resin, etc. which generate these gasses, may cause corrosion and discoloration of the modules. Do not use the LCD module under such environment.
- (12)When the module is installed, please take care not to pull and to hang LED_FFC.
- (13)Liquid crystal contained in the panel may leak if the LCD is broken. Rinse it as soon as possible if it gets inside your eye or mouth by mistake.
- (14)Be careful when using it for long time with fixed pattern display as it may cause accidental image.
- (15) Adjusting volume have been set optimally before shipment, so do not change any adjusted value. If adjusted value is changed, the specification may not be satisfied.
- (16)If a minute particle enters in the module and adheres to an optical material, it may cause display non-uniformity issue, etc. Therefore, fine-pitch filters have to be installed to cooling and inhalation hole if you intend to install a fan.
- (17)An abnormal display by changing in quality of the polarizing plate might occur regardless of contact or no contact to the polarizing plate, because of epoxy resin(amine system curing agent) that comes out from the material and the packaging material used for the set side, the silicon adhesive(dealcoholization system and ozime system), and the tray blowing agents(azo-compound), etc. Please confirm adaptability with your employed material.
- (18)The polarizer surface on the panel is treated with Anti-Glare for low reflection. In case of attaching protective board over the LCD, be careful about the optical interface fringe etc. which degrades display quality.



Document Title	M121MNS1 R1 Product Specification			Page No.	26/26
Document No.		Issue date	2012/10/9	Revision	00

(19)Notice: Never take to pieces the module, because it will cause failure. Please do not peel off the Black tape pasted to the product.

(20)When install LCD modules in the cabinet, please tighten with” torque=0.294±0.02N.m(3.0±0.2kgf.cm)

13.3 Storage Precaution

- (1) Please do not leave LCD module in the environment of high humidity and high temperature for a long time.
- (2) The module shall not be exposed under strong light such as direct sunlight. Otherwise, display characteristics may be changed.
- (3) The module should be stored in a dark place. It is prohibited to apply sunlight or fluorescent light in storage.

13.4 Operation Precaution

- (1) Do not connect or disconnect the module in the "Power On" condition.
- (2) Power supply should always be turned on/off by 12.1 "Power on/off sequence"
- (3) Module has high frequency circuits. Sufficient suppression to the electromagnetic interference should be done by system manufacturers. Grounding and shielding methods may be important to minimize the interference.
- (4) After installation of the TFT Module into an enclosure, do not twist nor bend the TFT Module even momentary. At designing the enclosure, it should be taken into consideration that no bending/twisting forces are applied to the TFT Module from outside. Otherwise the TFT Module may be damaged.

13.5 Others

- (1) Ultra-violet ray filter is necessary for outdoor operation.
- (2) Avoid condensation of water which may result in improper operation or disconnection of electrode.
- (3) If the module keeps displaying the same pattern for a long period of time, the image may be "sticked" to the screen.
- (4) This module has its circuitry PCB's on the rear side and should be handled carefully in order not to be stressed.

14.6 Disposal

When disposing LCD module, obey the local environmental regulations.