

# InfoVision Optoelectronics ( Kunshan ) Co.,LTD.

Document Title	M101GWT9 R3 customer approved specification	Page No.	1/29		
Document No.		Issue date	2016/5/20	Revision	00

## Product Information

**To:** 苏州与来视讯科技有限公司

**Product Name:** M101GWT9 R3

**Document Issue Date:** 2016/05/20

Customer	InfoVision Optoelectronics
<p><b><u>SIGNATURE</u></b></p> <p>_____</p> <p>_____</p> <p>Please return 1 copy for your confirmation with your signature and comments.</p>	<p><b><u>SIGNATURE</u></b></p> <p>QA</p> <p>_____</p> <p><b>PREPARED BY</b></p> <p>F AE</p> <p>_____</p>

Note: 1. Please contact InfoVision Company. Before designing your product based on this product.  
2. The information contained herein is presented merely to indicate the characteristics and performance of our products. No responsibility is assumed by IVO for any intellectual property claims or other problems that may result from application based on the module described herein.

FQ-7-30-0-009-02D

# InfoVision Optoelectronics ( Kunshan ) Co.,LTD.

Document Title	M101GWT9 R3 customer approved specification			Page No.	2/29
Document No.		Issue date	2016/5/20	Revision	00

Revision	Date	Page	Old Description	New Description	Remark
00	2016/05/20	ALL	-	First Issue	-

All rights strictly reserved reproduction or issue to third parties in any form what ever is not permitted without written authority from the proprietor.

# InfoVision Optoelectronics ( Kunshan ) Co.,LTD.

Document Title	M101GWT9 R3 customer approved specification			Page No.	3/29
Document No.		Issue date	2016/5/20	Revision	00

## CONTENTS

<b>1.0</b>	<b>GENERAL DESCRIPTIONS</b> .....	<b>4</b>
<b>2.0</b>	<b>ABSOLUTE MAXIMUM RATINGS</b> .....	<b>6</b>
<b>3.0</b>	<b>OPTICAL CHARACTERISTICS</b> .....	<b>7</b>
<b>4.0</b>	<b>ELECTRICAL CHARACTERISTICS</b> .....	<b>10</b>
<b>5.0</b>	<b>MECHANICAL CHARACTERISTICS</b> .....	<b>21</b>
<b>6.0</b>	<b>RELIABILITY CONDITIONS</b> .....	<b>24</b>
<b>7.0</b>	<b>PACKAGE SPECIFICATION</b> .....	<b>26</b>
<b>8.0</b>	<b>LOT MARK</b> .....	<b>27</b>
<b>9.0</b>	<b>GENERAL PRECAUTION</b> .....	<b>28</b>

# InfoVision Optoelectronics ( Kunshan ) Co.,LTD.

Document Title	M101GWT9 R3 customer approved specification	Page No.	4/29
Document No.	Issue date	2016/5/20	Revision 00

## 1.0 General Descriptions

### 1.1 Introduction

The M101GWT9 R3 is a color active matrix thin film transistor (TFT) liquid crystal display (LCD) that uses amorphous silicon TFT as a switching device. This model is composed of a TFT LCD panel, a driver circuit and a backlight system. This TFT LCD has a 10.1 inch diagonally measured active display area with WSVGA resolution (1,024 horizontal by 600 vertical pixels array).

### 1.2 Features

- Supported WSVGA Resolution
- LVDS Interface
- Compatible with RoHS Standard

### 1.3 Product Summary

Items	Specifications	Unit	Note
Screen Diagonal	10.1	inch	-
Active Area (H x V)	222.72 x 125.28	mm	-
Number of Pixels (H x V)	1,024 x600	-	-
Pixel Pitch (H x V)	0.2175 x 0.2088	mm	-
Pixel Arrangement	R.G.B. Vertical Stripe	-	-
Display Mode	Normally White	-	-
White Luminance	640 (Typ.)	cd /m <sup>2</sup>	-
Contrast Ratio	800 (Typ.)	-	-
Response Time	16 (Typ.)	ms	-
Input Voltage	3.3 (Typ.)	V	-
Power Consumption	4.85 (Max.)	W	-
Weight	440 (Max.)	g	-
Outline Dimension (H x V x D)	with PCBA	244.0(Typ.)x 143.0(Typ.)x12.9(Max)	mm -
	without PCBA	244.0(Typ.)x 143.0(Typ.)x7.7(Max)	
Electrical Interface (Logic)	LVDS	-	-
Support Color	262K/16.7M	-	-
NTSC	50 (Typ.)	%	-
Viewing Direction	12 o'clock	-	(2)
Flicker (Centre Point)	≤5%	-	(1)
Surface Treatment	Anti-glare, Hard-Coating (3H)	-	(3)

Note 1 The Data of Flicker is based on TM-672 Test.

Note 2 The gray inversion will be happened at 12 o'clock.

Note 3 The 3H According to JIS K5600 pencil test.

# InfoVision Optoelectronics ( Kunshan ) Co.,LTD.

Document Title	M101GWT9 R3 customer approved specification			Page No.	5/29
Document No.		Issue date	2016/5/20	Revision	00

## 1.4 Functional Block Diagram

Figure 1 shows the functional block diagram of the LCD module.

Figure 1 Block Diagram

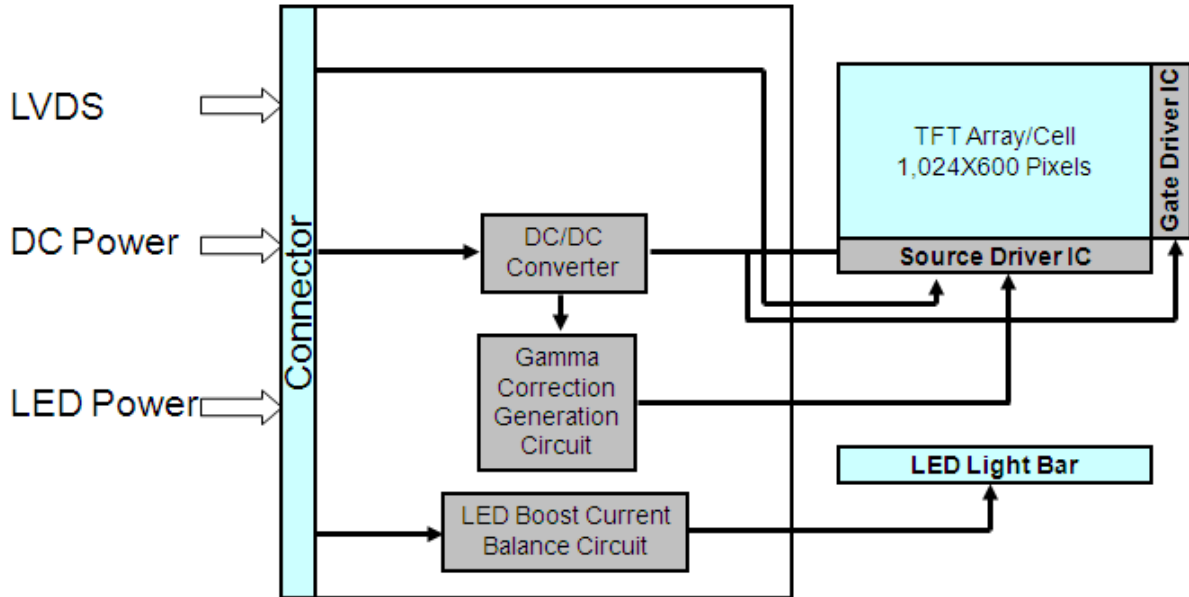

## 1.5 Pixel Mapping

Figure2 Pixel Mapping

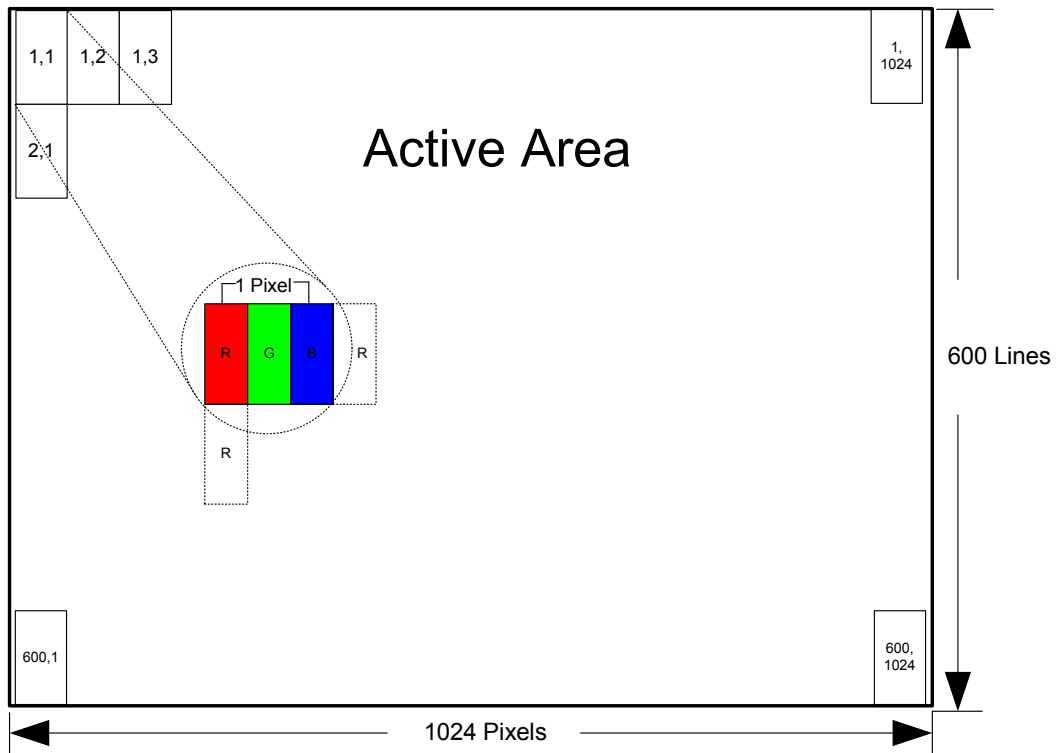

# InfoVision Optoelectronics ( Kunshan ) Co.,LTD.

Document Title	M101GWT9 R3 customer approved specification			Page No.	6/29
Document No.		Issue date	2016/5/20	Revision	00

## 2.0 Absolute Maximum Ratings

**Table 1 Electrical & Environment Absolute Rating**

Item	Symbol	Min.	Max.	Unit	Note
Logic Supply Voltage	$V_{DD}$	-0.3	5.0	V	(1),(2)
Logic Input Signal Voltage	$V_{Signal}$	-	3.6	V	
Operating Temperature	$T_{OP}$	-30	85	°C	(3),(4),(5),(6)
Storage Temperature	$T_{ST}$	-40	95	°C	
Vibration(Non-operating)	VB	-	2.9	G	(7)
Shock(Non-operating)	Shock	-	100	G	(8)

Note (1) Permanent damage may occur to the LCD module if beyond this specification. Functional operation should be restricted to the conditions described under normal operating conditions.

Note (2) Operating temperature 25°C, humidity 55%RH.

Note (3) ( $T \leq 40^\circ\text{C}$ ) Note static electricity. Maximum wet bulb temperature at 39°C or less. ( $T > 40^\circ\text{C}$ ) No condensation.

Note (4) There is a possibility of causing deterioration in the irregularity and others of the screen and the display fineness though the liquid crystal module doesn't arrive at destruction when using it at 85~95°C or -40~-30°C.

Note (5) There is a possibility of causing the fineness deterioration by the prolonged use in the (high temperature) humidity environment (60%RH or more).

Note (6) All the temperature items are the ambient temperature regulations.

**Figure 3 Absolute Ratings of Environment of the LCD Module**

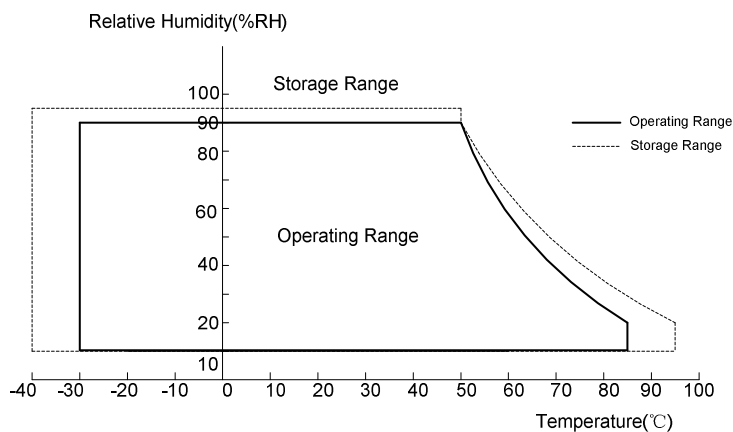

Note (7) Frequency range:8~33.3Hz; Stoke:1.3mm; Sweep:2.9G,33.3~400Hz; Cycle:15min; 2 hours for each direction of X, Z;4 hours for Y direction

Note (8) 100G,6ms,Half Sine Wave, ( $\pm X, \pm Y, \pm Z$ ), 3 times for each direction

# InfoVision Optoelectronics ( Kunshan ) Co.,LTD.

Document Title	M101GWT9 R3 customer approved specification	Page No.	7/29
Document No.	Issue date	2016/5/20	Revision 00

### 3.0 Optical Characteristics

The optical characteristics are measured under stable conditions as following notes.

**Table 2 Optical Characteristics**

Item	Conditions	Min.	Typ.	Max.	Unit	Note		
Viewing Angle (CR>10)	Horizontal	$\theta_{x+}$	70	80	-	degree  (1),(2),(3)		
		$\theta_{x-}$	70	80	-			
	Vertical	$\theta_{y+}$	70	80	-			
		$\theta_{y-}$	70	80	-			
Contrast Ratio	Center	640	800	-	-	(1),(2),(4) $\theta_x=\theta_y=0^\circ$		
Response Time	Rising + Falling (25°C)	-	16	25	ms	(1),(2),(5) $\theta_x=\theta_y=0^\circ$		
	Rising + Falling (-30°C)	-	323	550	ms	(2),(5) $\theta_x=\theta_y=0^\circ$		
Color Chromaticity (CIE1931)	Red x	Typ. -0.03	0.579	Typ. +0.03	-	(1),(2),(3) $\theta_x=\theta_y=0^\circ$		
	Red y		0.344		-			
	Green x		0.326		-			
	Green y		0.591		-			
	Blue x		0.159		-			
	Blue y		0.131		-			
	White x		0.255		0.305		0.355	-
	White y		0.275		0.325		0.375	-
NTSC	-	45	50	-	%	(1),(2),(3) $\theta_x=\theta_y=0^\circ$		
White Luminance	Center_	580	640	-	cd/m <sup>2</sup>	(1),(2),(6) $\theta_x=\theta_y=0^\circ$		
Luminance Uniformity	9 Points	75	80	-	%	(1),(2),(7) $\theta_x=\theta_y=0^\circ$		

Note (1) Measurement Setup:

The LCD module should be stabilized at given temperature (25°C) for 15 minutes to avoid abrupt temperature change during measuring. In order to stabilize the luminance, the measurement should be executed after lighting backlight for 15 minutes in a windless room.

# InfoVision Optoelectronics ( Kunshan ) Co.,LTD.

Document Title	M101GWT9 R3 customer approved specification		Page No.	8/29	
Document No.		Issue date	2016/5/20	Revision	00

**Figure 4 Measurement Setup**

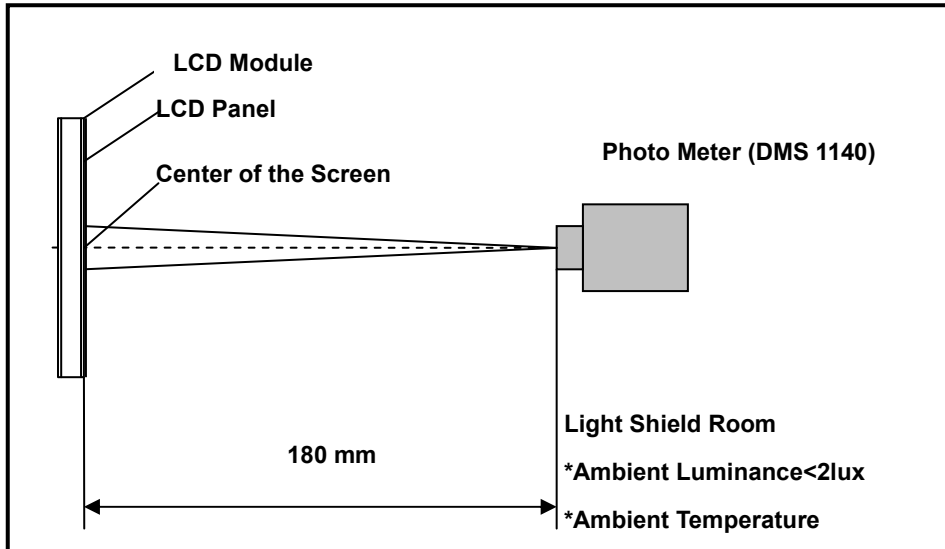

Note (2) The LED input parameter setting as:

$I_{LED}$ : 160mA  
 $PWM_{LED}$ : Duty 100 %

Note (3) Definition of Viewing Angle

**Figure 5 Definition of Viewing Angle**

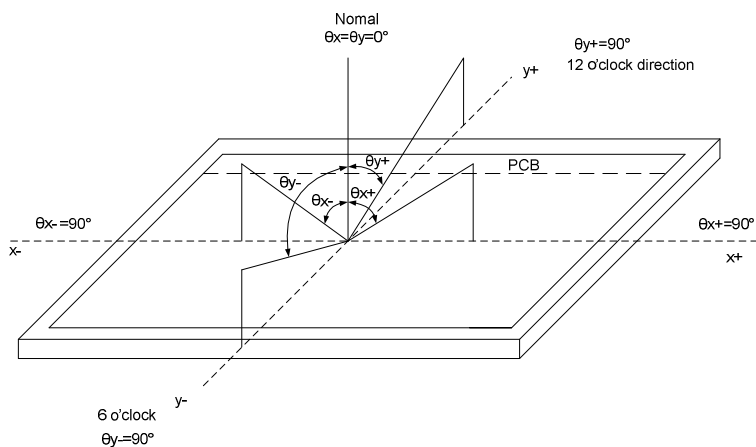

Note (4) Definition Of Contrast Ratio (CR)

The contrast ratio can be calculated by the following expression:

$$\text{Contrast Ratio (CR)} = L_{63} (L_{255}) / L_0$$

$L_{63}$  ( $L_{255}$ ): Luminance of gray level 63(6bit) or level 255(8bit),  $L_0$ : Luminance of gray level 0

Note (5) Definition Of Response Time ( $T_R$ ,  $T_F$ )



# InfoVision Optoelectronics ( Kunshan ) Co.,LTD.

Document Title	M101GWT9 R3 customer approved specification	Page No.	9/29
Document No.	Issue date	2016/5/20	Revision 00

**Figure 6 Definition of Response Time**

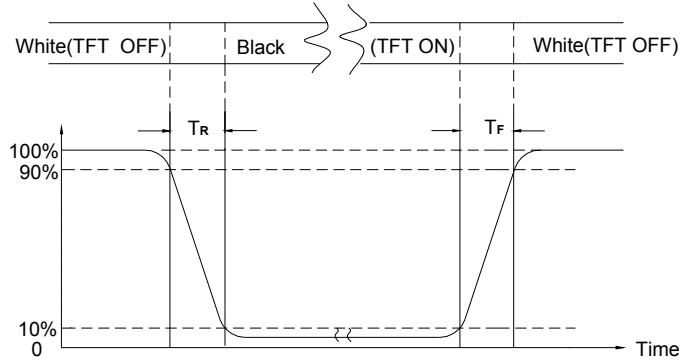

Note (6) Definition Of Luminance White

Measure the luminance of gray level 63(6bit) or level 255(8bit) at center.

Note (7) Definition Of Luminance Uniformity (Ref.: Active Area)

Measure the luminance of gray level 63(6bit) or level 255(8bit) at 9 points.

Luminance Uniformity=  $\text{Min.}(L1, L2, \dots L9) / \text{Max.}(L1, L2, \dots L9)$

H—Active Area Length,    V—Active Area Width,    L—Luminance

**Figure 7 Measurement Locations of 9 Points**

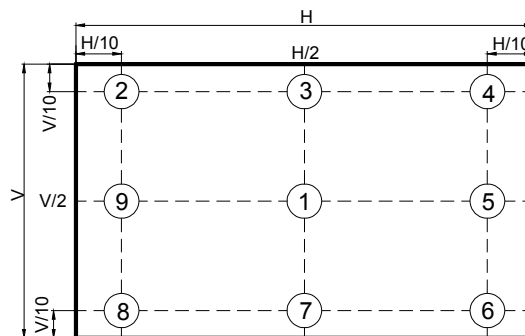

# InfoVision Optoelectronics ( Kunshan ) Co.,LTD.

Document Title	M101GWT9 R3 customer approved specification	Page No.	10/29
Document No.	Issue date	2016/5/20	Revision 00

## 4.0 Electrical Characteristics

### 4.1 Interface Connector

**Table 3 Signal Connector Type**

Item	Description
Manufacturer / Type	STM / MSB240420HD
Mating Receptacle / Type (Reference)	STM / P240420H or Compatible

**Table 4 Signal Connector Pin Assignment**

Pin No.	Symbol	Description	Remarks
1	VDD	Power Supply, 3.3V (Typ.)	-
2	VDD	Power Supply, 3.3V (Typ.)	-
3	VSS	Ground	-
4	REV	Reverse Scan selection	-
5	Rin1-	-LVDS differential data input (R0-R5,G0)	-
6	Rin1+	+LVDS differential data input (R0-R5,G0)	-
7	VSS	Ground	-
8	Rin2-	-LVDS differential data input (G1-G5,B0-B1)	-
9	Rin2+	+LVDS differential data input (G1-G5,B0-B1)	-
10	VSS	Ground	-
11	Rin3-	-LVDS differential data input (B2-B5,HS,VS,DE)	-
12	Rin3+	+LVDS differential data input (B2-B5,HS,VS,DE)	-
13	VSS	Ground	-
14	ClkIN-	-LVDS differential clock input	-
15	ClkIN+	+LVDS differential clock input	-
16	GND	Ground	-
17	Rin4-	-LVDS differential data input (R6-R7,G6-G7,B6-B7)	-
18	Rin4+	+LVDS differential data input (R6-R7,G6-G7,B6-B7)	-
19	SEL68	6/8 bits LVDS data input	Table 5
20	NC	Not connection	-

# InfoVision Optoelectronics ( Kunshan ) Co.,LTD.

Document Title	M101GWT9 R3 customer approved specification	Page No.	11/29
Document No.	Issue date	2016/5/20	Revision 00

**Table 5 SEL68 Power Voltage Specifications**

Signal Name	SYMBOL	MIN.	TYP.	MAX.	UNIT
SEL68	VH	2.0	3.3	5.0	V
	VL	-	-	0.8	V

**Table 6 LED Connector Name / Designation**

Item	Description
Manufacturer / Type	STM / MSB24038P5A
Mating Receptacle / Type (Reference)	STM / P24038P5 or Compatible

**Table 7 LED Connector Pin Assignment**

Pin No.	Symbol	Description	Remarks
1	VCC	Power Supply, 12V (Typ.)	-
2	GND	Ground	-
3	EN	3.3V (Typ.)	-
4	PWM	3.3V (Typ.)	-
5	NC	Not Connection	-

# InfoVision Optoelectronics ( Kunshan ) Co.,LTD.

Document Title	M101GWT9 R3 customer approved specification			Page No.	12/29
Document No.		Issue date	2016/5/20	Revision	00

## 4.2 Signal Electrical Characteristics

### 4.2.1 Signal Electrical Characteristics For LVDS Receiver

The built-in LVDS receiver is compatible with (ANSI/TIA/TIA-644 ) standard.

**Table 8 LVDS Receiver Electrical Characteristics**

Parameter	Symbol	Min.	Typ.	Max.	Unit	Conditions
Differential Input High Threshold	$V_{th}$	-	-	+100	mV	$V_{CM}=+1.2V$
Differential Input Low Threshold	$V_{tl}$	-100	-	-	mV	$V_{CM}=+1.2V$
Magnitude Differential Input	$ V_{ID} $	200	-	600	mV	-
Common Mode Voltage	$V_{CM}$	1.0	1.2	1.4	V	$V_{th} - V_{tl} = 200mV$
Common Mode Voltage Offset	$\Delta V_{CM}$	-50	-	+50	mV	$V_{th} - V_{tl} = 200mV$

Note (1) Input signals shall be low or Hi- resistance state when VDD is off.

Note (2) All electrical characteristics for LVDS signal are defined and shall be measured at the interface connector of LCD.

**Figure 8 Voltage Definitions**

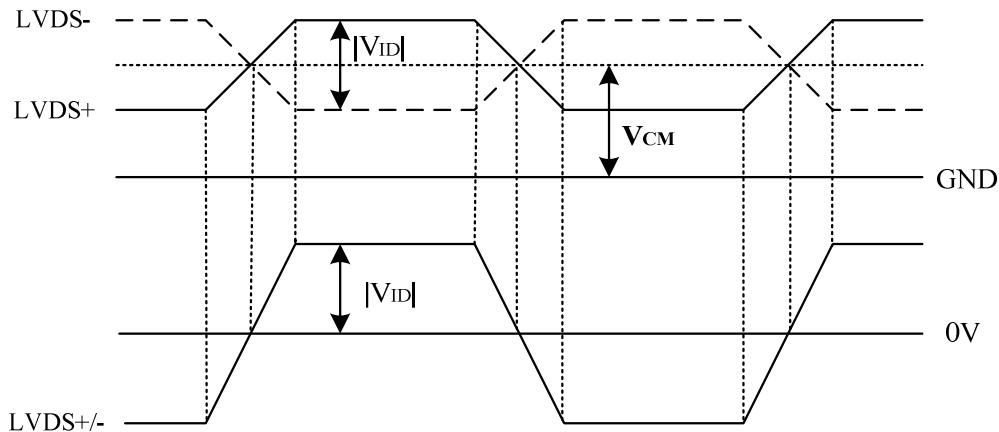

# InfoVision Optoelectronics ( Kunshan ) Co.,LTD.

Document Title	M101GWT9 R3 customer approved specification			Page No.	13/29
Document No.		Issue date	2016/5/20	Revision	00

**Figure 9 Measurement System**

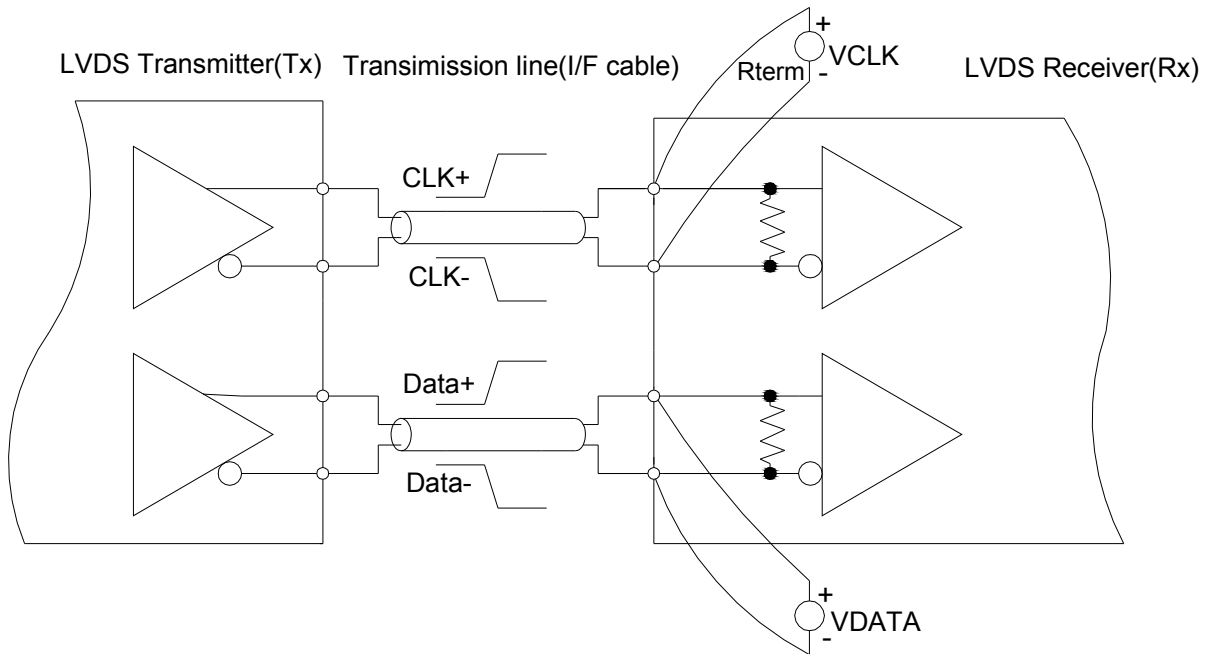

**Figure 10 Data Mapping**

**6 bit LVDS input:**

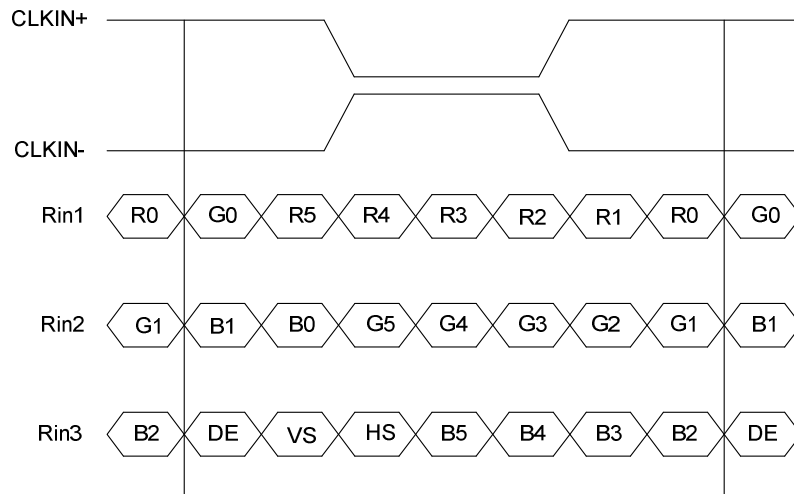

# InfoVision Optoelectronics ( Kunshan ) Co.,LTD.

Document Title	M101GWT9 R3 customer approved specification	Page No.	14/29
Document No.	Issue date	2016/5/20	Revision 00

## 8 bit LVDS input:

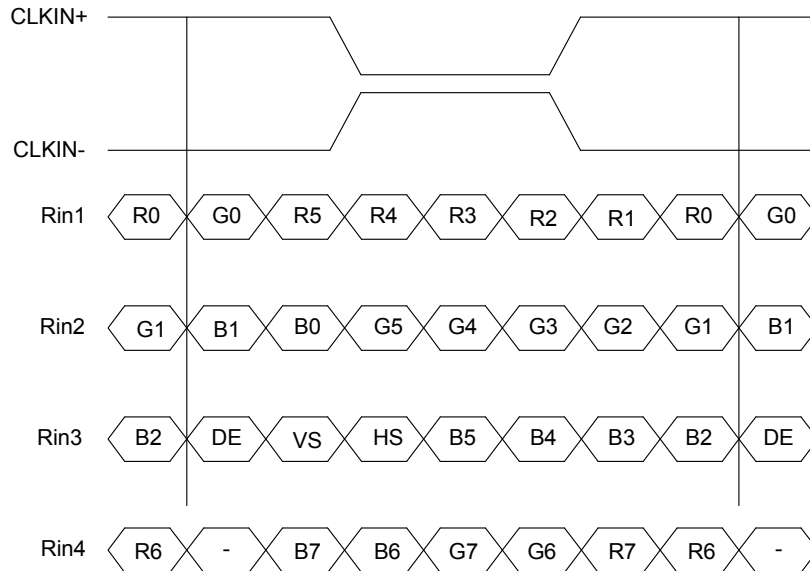

# InfoVision Optoelectronics ( Kunshan ) Co.,LTD.

Document Title	M101GWT9 R3 customer approved specification			Page No.	15/29
Document No.		Issue date	2016/5/20	Revision	00

## 4.2.2 LVDS Receiver Internal Circuit

Figure 11 shows the internal block diagram of the LVDS receiver. This LCD module equips termination resistors for LVDS link.

**Figure 11 LVDS Receiver Internal Circuit**

**6 bit:**

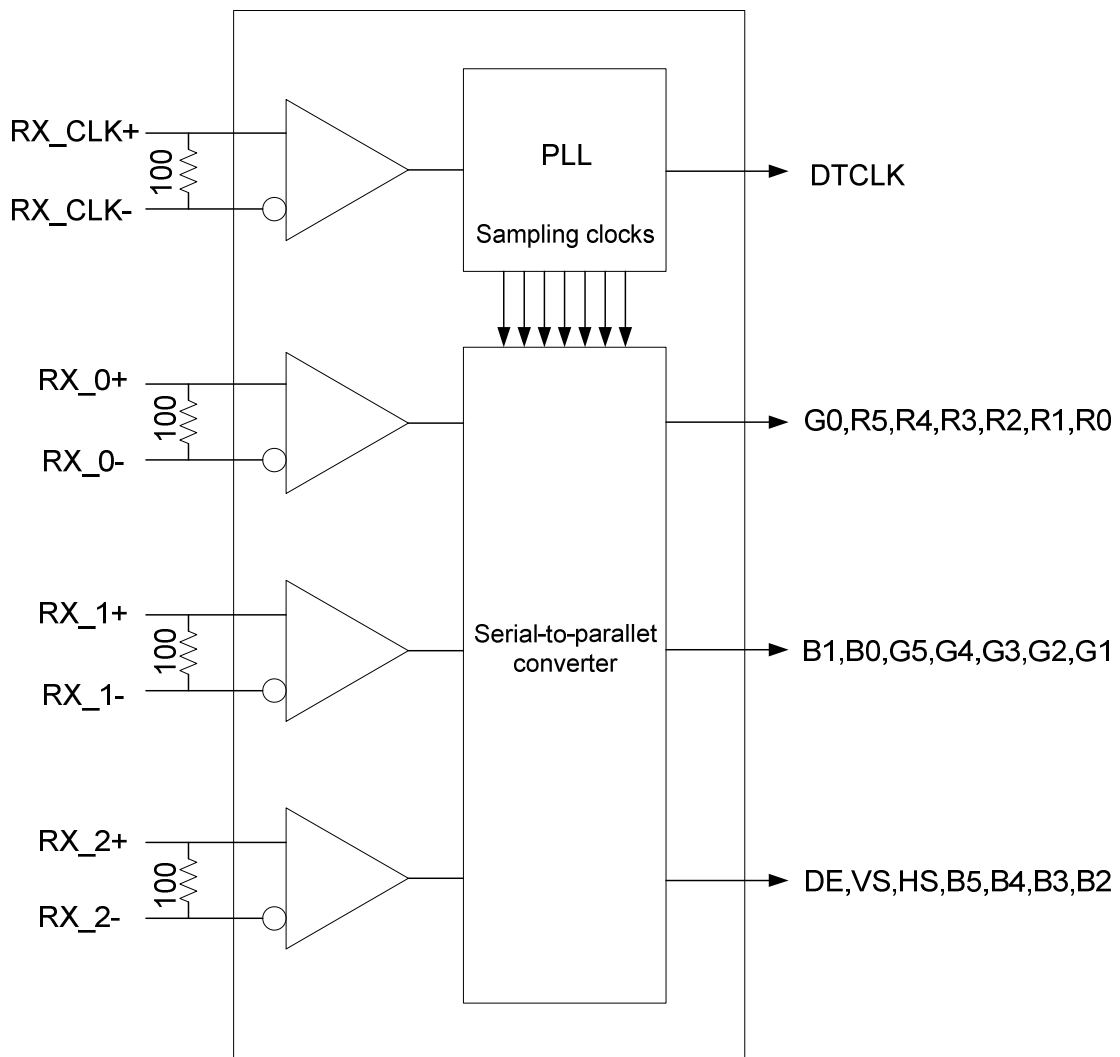

# InfoVision Optoelectronics ( Kunshan ) Co.,LTD.

Document Title	M101GWT9 R3 customer approved specification	Page No.	16/29
Document No.	Issue date	2016/5/20	Revision 00

**8 bit:**

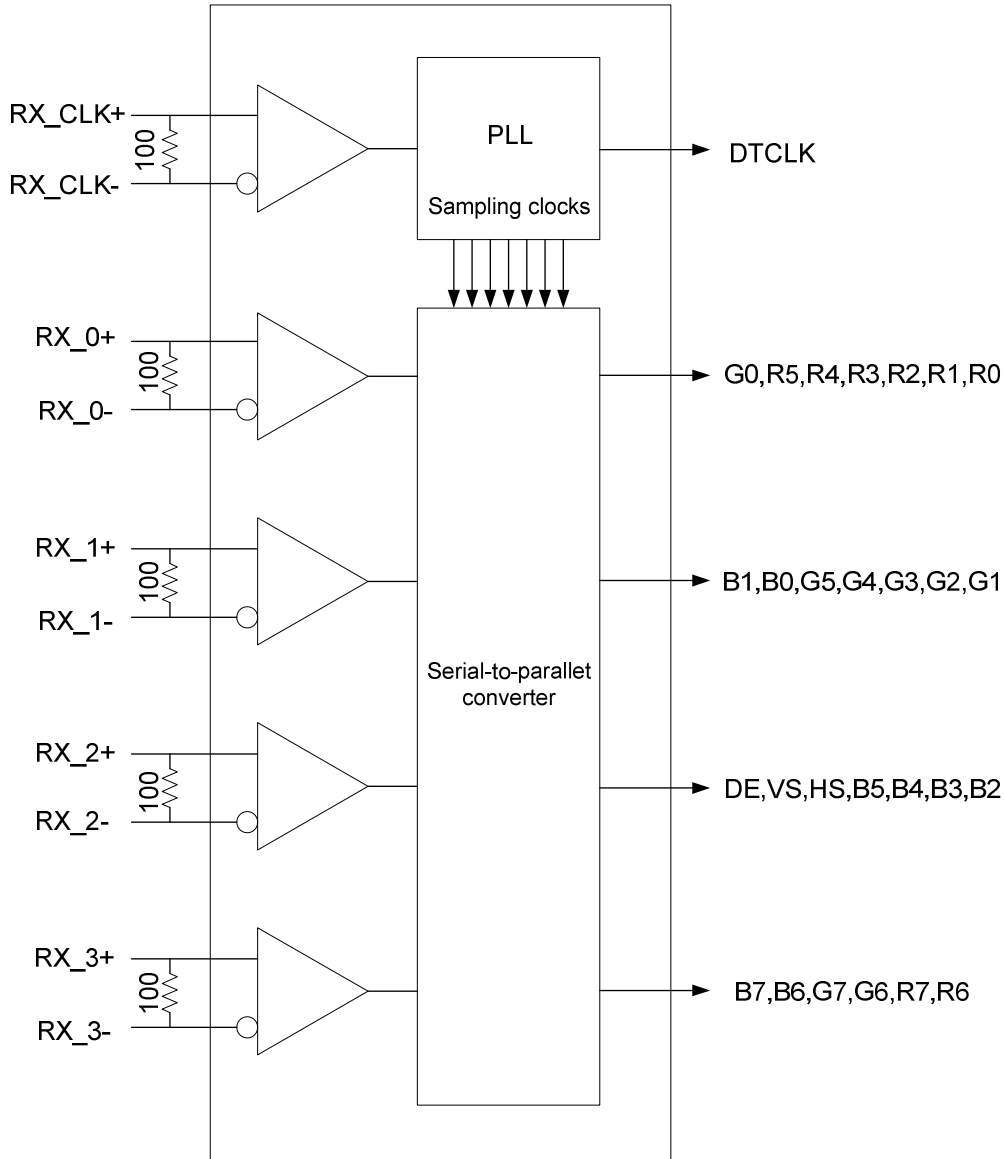

## 4.3 Interface Timings

**Table 9 Interface Timings**

Parameter	Symbol	Min.	Typ.	Max.	Unit
LVDS Clock Frequency	Fclk	45	51.2	57	MHz
H Total Time	HT	1,324	1,344	1,364	Clocks
H Active Time	HA	1,024	1,024	1,024	Clocks
V Total Time	VT	625	635	645	Lines
V Active Time	VA	600	600	600	Lines
Frame Rate	FV	55	60	65	Hz

All rights strictly reserved reproduction or issue to third parties in any form what ever is not permitted without written authority from the proprietor.



# InfoVision Optoelectronics ( Kunshan ) Co.,LTD.

Document Title	M101GWT9 R3 customer approved specification	Page No.	17/29
Document No.	Issue date	2016/5/20	Revision 00

## 4.4 Input Power Specifications

Input power specifications are as follows.

**Table 10 Input Power Specifications**

Parameter	Symbol	Min.	Typ.	Max.	Unit	Note	
<b>System Power Supply</b>							
LCD Drive Voltage (Logic)	$V_{DD}$	3.0	3.3	3.6	V	(2), (4)	
Vcom Voltage	$V_{com}$	3.52	-	4.99	V		
VDD Current	Black Pattern	$I_{DD}$	-	-	0.19	A	(3),(4)
VDD Power Consumption	Black Pattern	$P_{DD}$	-	-	0.63	W	
Rush Current		$I_{Rush}$	-	-	1.5	A	(1),(4),(5)
Allowable Logic/LCD Drive Ripple Voltage		$V_{VDD-RP}$	-	-	200	mV	(4)
<b>LED Power Supply</b>							
LED Input Voltage	$V_{LED}$	8	12	16	V	(4),(6)	
LED Power Consumption	$P_{LED}$	-	-	4.22	W	(4),(6)	
LED Forward Voltage	$V_F$	2.8	3.2	3.6	V	(4)	
LED Forward Current	$I_F$	-	80	-	mA		
EFFICIENCY	EFF	85	-	-	%		
PWM Signal Voltage	High	$V_{PWM}$	2.0	3.3	5.0		V
	Low		-	-	0.8		
LED Enable Voltage	High	$V_{LED\_EN}$	2.0	3.3	5.0		V
	Low		-	-	0.8		
Input PWM Frequency	$F_{PWM}$	100	-	1,000	Hz		
Duty Ratio	PWM	5	-	100	%		
LED Life Time	LT	50,000	-	-	Hours		(4),(7),(8)

Note (1) Measure Condition

**Figure 12 VDD Rising Time**

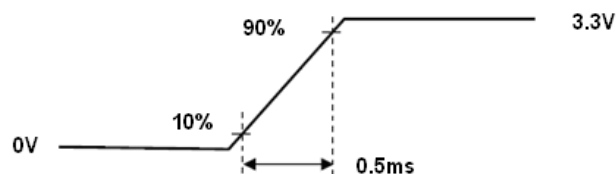

# InfoVision Optoelectronics ( Kunshan ) Co.,LTD.

Document Title	M101GWT9 R3 customer approved specification	Page No.	18/29
Document No.	Issue date	2016/5/20	Revision
			00

Note (2) VDD Power Dip Condition

$V_{TH} < V_{DD} \leq V_{min}$ ,  $t_d \leq 10ms$  (a time of the voltage return to normal), our panel can revive automatically.

**Figure 13 VDD Power Dip**

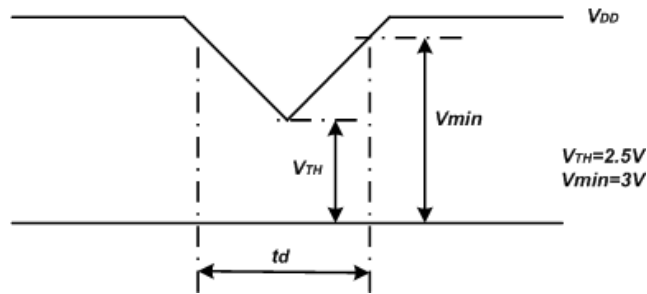

Note (3) Frame Rate=60Hz, VDD=3.3V, DC Current.

Note (4) Operating temperature 25°C, humidity 55%RH.

Note (5) The reference measurement circuit of rush current.

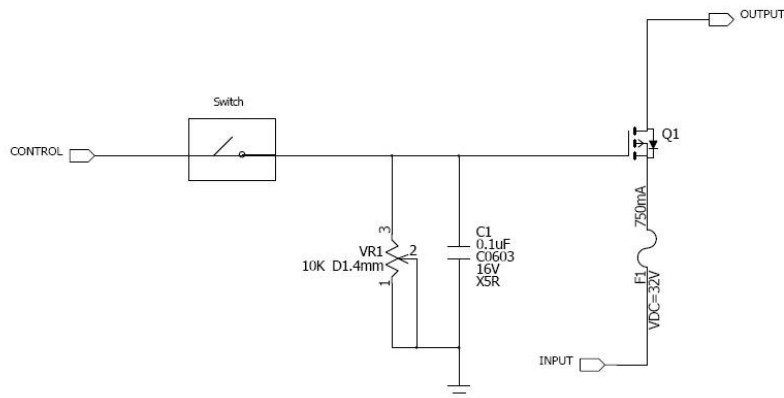

Note (6) Definition of  $V_{LED}$  and  $P_{LED}$

$$V_{LED} = V_F \times 7 \quad P_{LED} = V_{LED} \times I_F \times 2$$

**Figure 14 LED Light Bar Structure**

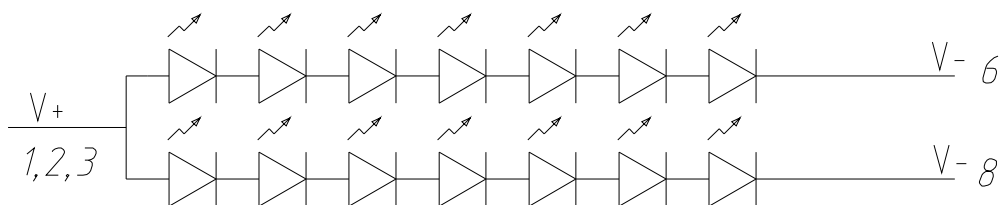

Note: Pad 4, 5, 7 are NC.

# InfoVision Optoelectronics ( Kunshan ) Co.,LTD.

Document Title	M101GWT9 R3 customer approved specification			Page No.	19/29
Document No.		Issue date	2016/5/20	Revision	00

**Figure 15 Ambient Temperature VS Allowable Forward Current**

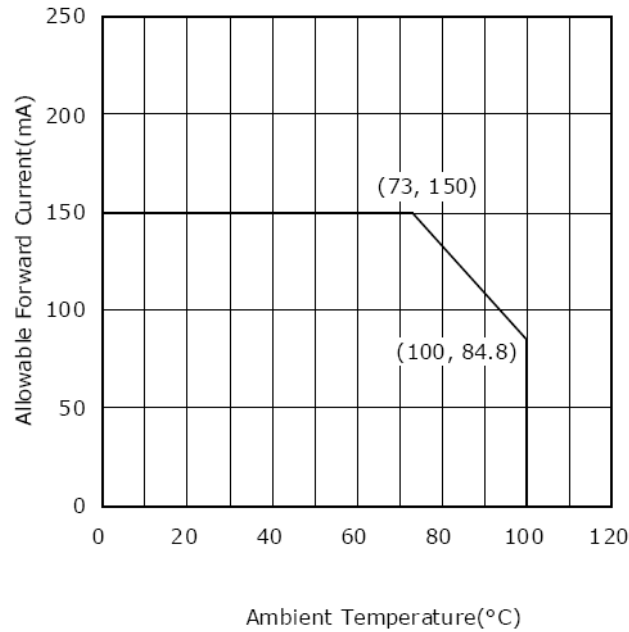

Note (7) The LED life time define as the estimated time to 50% degradation of initial luminous.

Note (8) The LED type is NSSW150BT.

# InfoVision Optoelectronics ( Kunshan ) Co.,LTD.

Document Title	M101GWT9 R3 customer approved specification	Page No.	20/29
Document No.		Issue date	2016/5/20
		Revision	00

## 4.5 Power ON/OFF Sequence

Interface signals are also shown in the chart. Signals from any system shall be Hi-resistance state or low level when VDD voltage is off.

**Figure 16 Power Sequence**

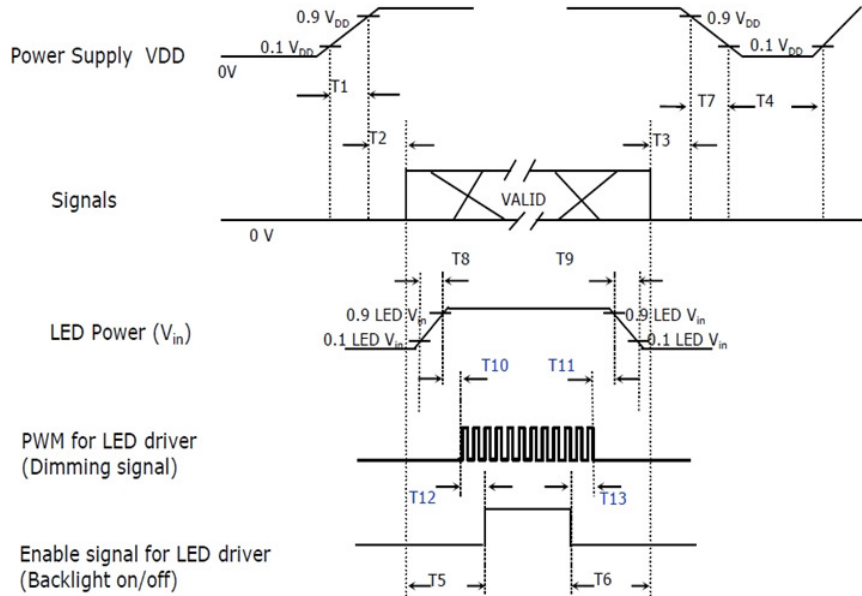

**Table 11 Power Sequencing Requirements**

Parameter	Symbol	Unit	min	Typ.	max
VDD rising Time from 10% to 90%	T1	ms	0.5	-	10
Delay from VDD to valid data at power ON	T2	ms	0	-	50
Delay from valid data OFF to VDD OFF at power OFF	T3	ms	0	-	50
VDD OFF time for Windows restart	T4	ms	500	-	-
Delay from valid data to B/L enable at power ON	T5	ms	200	-	-
Delay from valid data off to B/L disable at power OFF	T6	ms	200	-	-
VDD falling time from 90% to 10%	T7	ms	0	-	10
LED Vin rising time from 10% to 90%	T8	ms	0.5	-	10
LED Vin falling time from 90% to 10%	T9	ms	0.5	-	10
Delay from LED driver Vin rising time 90% to PWM ON	T10	ms	0	-	10
Delay from PWM Off to LED Driver Vin falling time 10%, Must Keep rule	T11	ms	0	-	-
Delay from PWM ON to B/L Enable ON, Must Keep rule	T12	ms	0	-	-
Delay from B/L Enable Off to PWM Off	T13	ms	0	-	-

# InfoVision Optoelectronics ( Kunshan ) Co.,LTD.

Document Title	M101GWT9 R3 customer approved specification			Page No.	21/29
Document No.		Issue date	2016/5/20	Revision	00

## 5.0 Mechanical Characteristics

### 5.1 Outline Drawing

Figure 17 Reference Outline Drawing (Front Side)

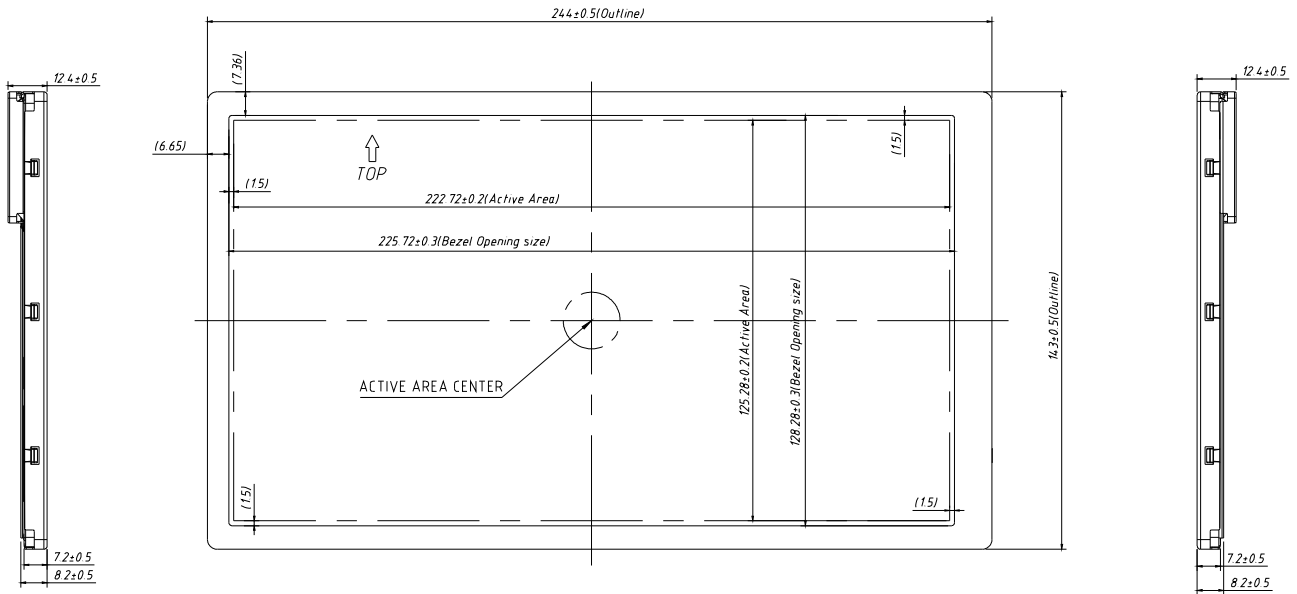

Unit: mm

# InfoVision Optoelectronics ( Kunshan ) Co.,LTD.

Document Title	M101GWT9 R3 customer approved specification		Page No.	22/29	
Document No.		Issue date	2016/5/20	Revision	00

**Figure 18 Reference Outline Drawing (Back Side)**

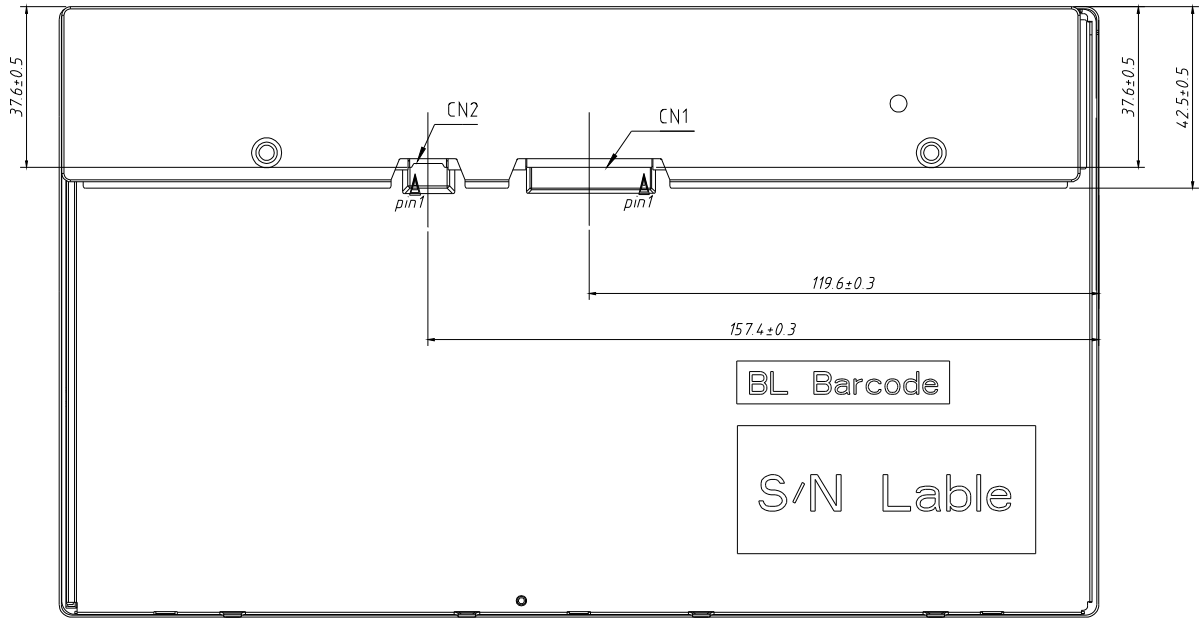

Unit: mm

# InfoVision Optoelectronics ( Kunshan ) Co.,LTD.

Document Title	M101GWT9 R3 customer approved specification			Page No.	23/29
Document No.		Issue date	2016/5/20	Revision	00

## 5.2 Dimension Specifications

**Table 12 Module Dimension Specifications**

Item		Min.	Typ.	Max.	Unit
Width		243.7	244	244.3	mm
Height		142.7	143	143.3	mm
Thickness	with PCBA	-	-	12.9	mm
	without PCBA	-	-	7.7	mm
Weight		-	400	440	g

**Figure 19 BM Area**

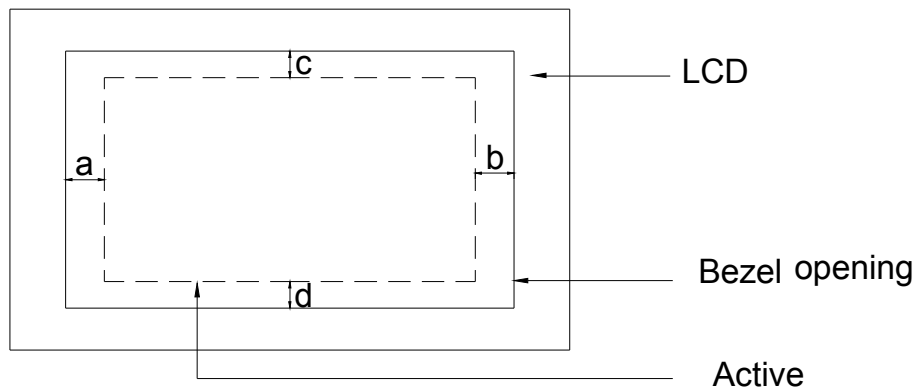

Note: The a, b, c and d mean distance from Active Area to Bezel opening.

# InfoVision Optoelectronics ( Kunshan ) Co.,LTD.

Document Title	M101GWT9 R3 customer approved specification	Page No.	24/29
Document No.	Issue date	2016/5/20	Revision 00

## 6.0 Reliability Conditions

Item	Package	Test Conditions	Note	
High Temperature Operating Test	Module	85°C, 300 hours	(1),(2),(3),(4)	
Low Temperature Operating Test	Module	-30°C, 300 hours		
High Temperature Storage Test	Module	95°C, 300 hours	(1),(2),(4)	
Low Temperature Storage Test	Module	-40°C, 300 hours		
High Temperature/High Humidity Operating Test	Module	60°C, 90%RH, 300 hours	(1),(2),(3),(4)	
Shock Non-operating Test	Module	3 shock in each direction Peak acceleration:981m/s <sup>2</sup> Duration of normal shock; 6ms Wave form saw-tooth with slow rise(2.04m/s)	(4)	
Vibration Non-operating Test	Module	1.5G, 10~500 Hz , x、 y、 z each axis/1hour.		
ESD Test	Operating	Contact	± 8 KV, 150pF(330Ohm)	(5)
		Air	± 15 KV, 150pF(330Ohm)	
	Non-operating	Contact	± 10KV, 150pF(330Ohm)	
		Air	±20KV, 150pF(330Ohm)	
Package Vibration Test	Module	0.015G <sup>2</sup> /Hz from 5~200Hz, -6dB/Octave from 200~500Hz	-	
Package Drop test	Module	65cm, 1corner,3 arris,6 side	(6)	

Note (1) All the judgments are under room temperature and the sample need to be static more than 2 hours in the room temperature before judge.

Note (2) During measurement, the condensation water or remains shall not be allowed.

Note (3) In operating test, the backlight voltage and current must be in specification.

Note (4) There is no display function issue occurred, all the cosmetic specification is judged before the reliability stress.

Note (5) In case of malfunction defect caused by ESD damage. If it would be recovered to normal state after resetting, it would be judge as pass.

Note (6) Package Drop Test Location as below:



# InfoVision Optoelectronics ( Kunshan ) Co.,LTD.

Document Title	M101GWT9 R3 customer approved specification			Page No.	25/29
Document No.		Issue date	2016/5/20	Revision	00

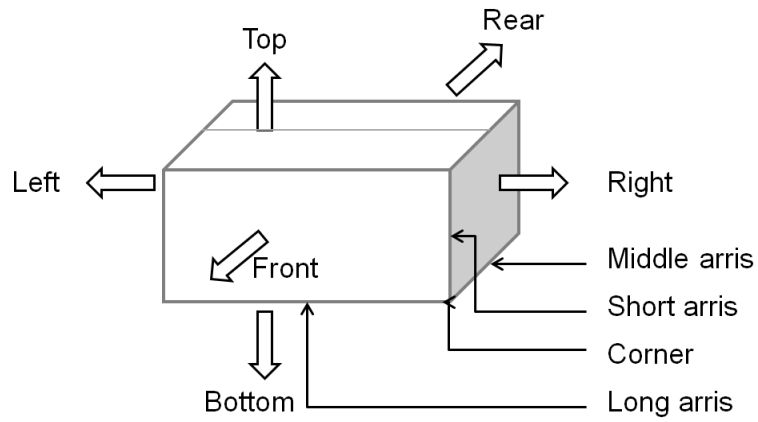

# InfoVision Optoelectronics ( Kunshan ) Co.,LTD.

Document Title	M101GWT9 R3 customer approved specification			Page No.	26/29
Document No.		Issue date	2016/5/20	Revision	00

## 7.0 Package Specification

Figure 20 Packing Method

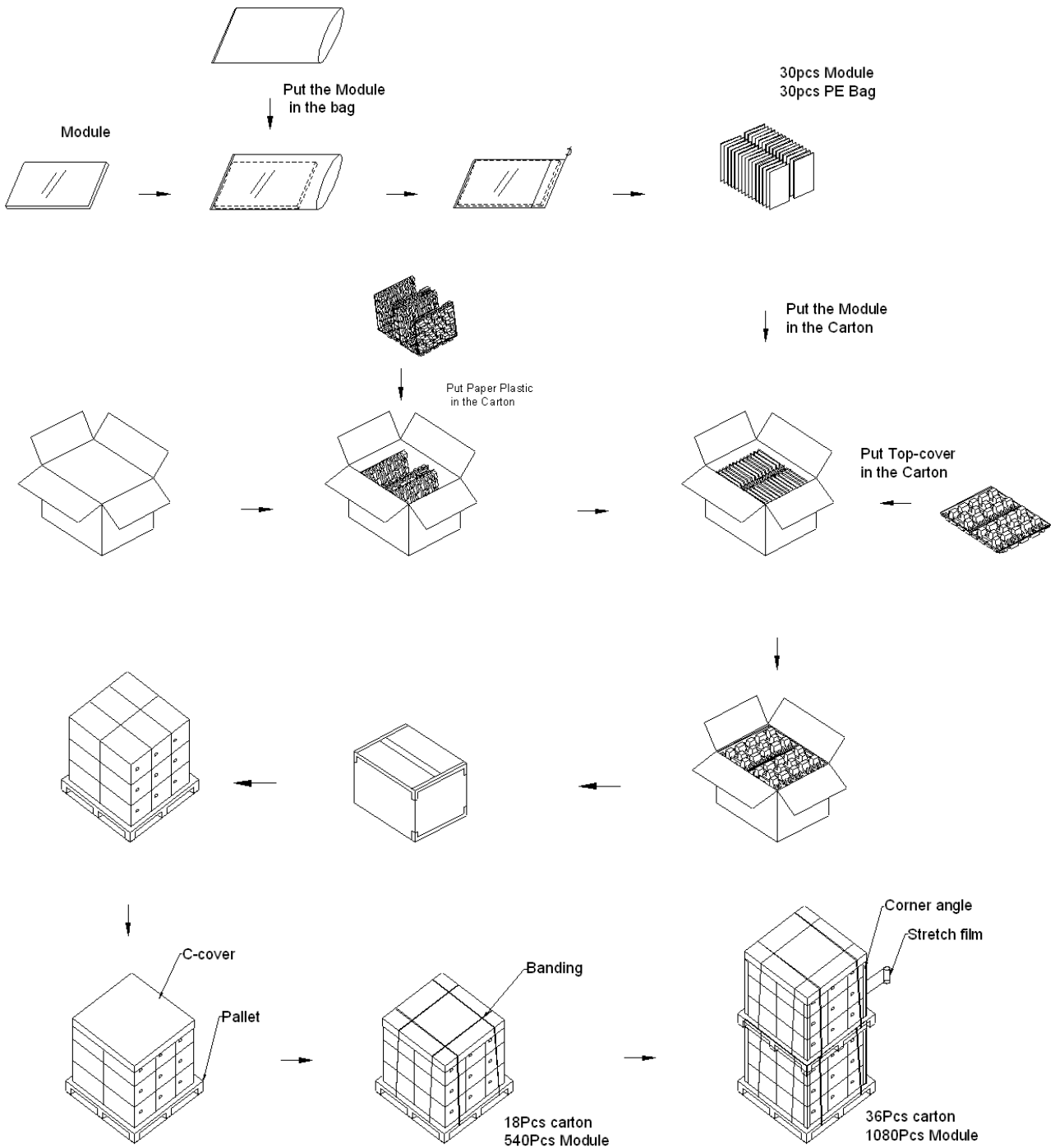

# InfoVision Optoelectronics ( Kunshan ) Co.,LTD.

Document Title	M101GWT9 R3 customer approved specification			Page No.	27/29
Document No.		Issue date	2016/5/20	Revision	00

## 8.0 Lot Mark

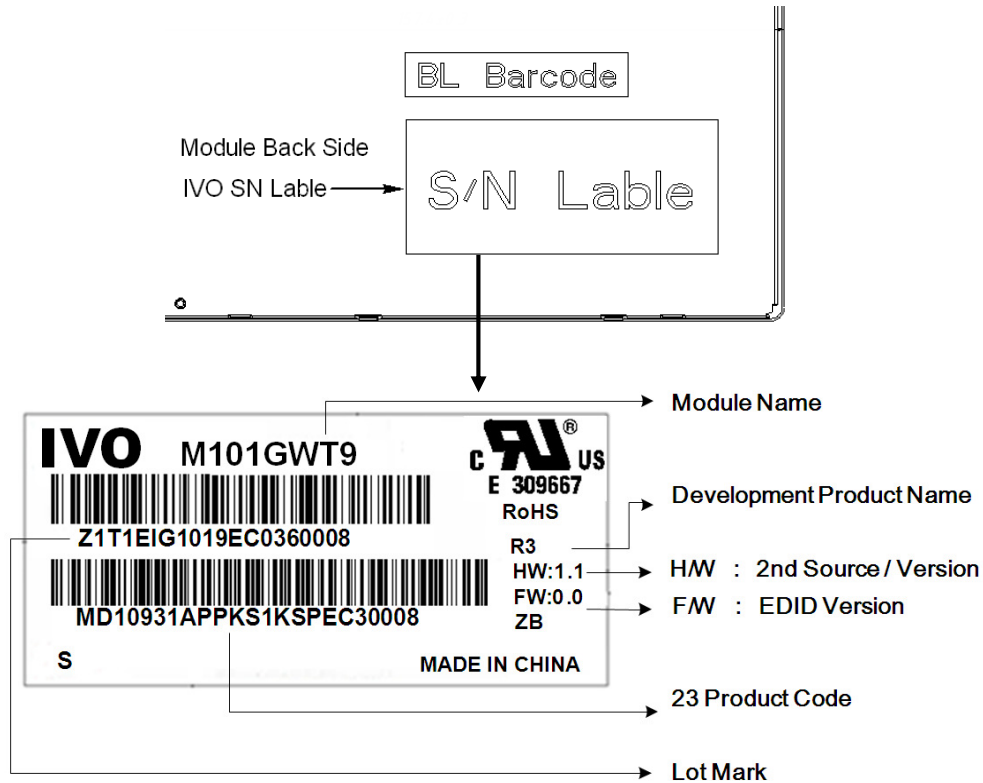

Note: This picture is only an example.

### 8.1 20 Lot Mark

1	2	3	4	5	6	7	8	9	10	11	12	13	14	15	16	17	18	19	20
---	---	---	---	---	---	---	---	---	----	----	----	----	----	----	----	----	----	----	----

Code 1,2,4,5,6,7,8,9,10,11,16: IVO internal flow control code.

Code 3: Production Location.

Code 12: Production Year.

Code 13: Production Month.

Code 14,15: Production Day.

Code 17,18,19,20: Serial Number.

### 8.2 23 Product Barcode

1	2	3	4	5	6	7	8	9	10	11	12	13	14	15	16	17	18	19	20	21	22	23
---	---	---	---	---	---	---	---	---	----	----	----	----	----	----	----	----	----	----	----	----	----	----

Code 1,2: Manufacture District.

Code 3,4,5,6,7: IVO internal module name.

Code 8,9,10,13,16: IVO internal flow control code.

Code 11,12: Cell location Suzhou, China defined as "KS".

Code 14,15: Module location Kunshan, China defined as "KS"; Yangzhou, China defined as "YZ"; Shenzhen, China defined as "SE"; Zhuhai, China defined as "ZH"; Suzhou, China defined as "SZ".

Code 17,18,19 : Year, Month, Day refer to Note(1), Note(2) and Note(3).

# InfoVision Optoelectronics ( Kunshan ) Co.,LTD.

Document Title	M101GWT9 R3 customer approved specification				Page No.	28/29
Document No.		Issue date	2016/5/20	Revision	00	

Note (1) Production Year

Year	2006	2007	2008	2009	2010	2011	2012	2013	.....	2035
Mark	6	7	8	9	A	B	C	D	.....	Z

Note (2) Production Month

Month	Jan.	Feb.	Mar.	Apr.	May.	Jun.	Jul.	Aug.	Sep.	Oct	Nov.	Dec.
Mark	1	2	3	4	5	6	7	8	9	A	B	C

Note (3) Production Day: 1~V.

Code 20~23: Serial Number.

## 9.0 General Precaution

### 9.1 Use Restriction

This product is not authorized for use in life supporting systems, aircraft navigation control systems, military systems and any other application where performance failure could be life-threatening or otherwise catastrophic.

### 9.2 Handling Precaution

- (1) Please mount LCD module by using mounting holes arranged in four corners tightly.
- (2) Do not disassemble or modify the module. It may damage sensitive parts inside LCD module, and may cause scratches or dust on the display. IVO does not warrant the module, if customers disassemble or modify the module.
- (3) If LCD panel is broken and liquid crystal spills out, do not ingest or inhale liquid crystal, and do not contact liquid crystal with skin. If liquid crystal contacts mouth or eyes, rinse out with water immediately. If liquid crystal contacts skin or cloths, wash it off immediately with alcohol and rinse thoroughly with water.
- (4) Disconnect power supply before handling LCD module.
- (5) Refrain from strong mechanical shock and /or any force to the module.
- (6) Do not exceed the absolute maximum rating values, such as the supply voltage variation, input voltage variation, variation in parts parameters, environmental temperature; etc otherwise LCD module may be damaged. It's recommended employing protection circuit for power supply.
- (7) Do not touch, push or rub the polarizer with anything harder than HB pencil lead. Use fingerstalls of soft gloves in order to keep clean display quality, when persons handle the LCD module for incoming inspection or assembly.
- (8) When the surface is dusty, please wipe gently with absorbent cotton or other soft material. When cleaning the adhesives, please use absorbent cotton wetted with a little petroleum benzene or other adequate solvent.
- (9) Wipe off saliva or water drops as soon as possible. If saliva or water drops contact with polarizer for a long time, they may causes deformation or color fading.
- (10) Protection film must remove very slowly from the surface of LCD module to prevent from electrostatic occurrence.
- (11) Because LCD module uses CMOS-IC on circuit board and TFT-LCD panel, it is very weak to electrostatic discharge, please be careful with electrostatic discharge. Persons who handle the module should be grounded through adequate methods.
- (12) Do not adjust the variable resistor located on the module.

### 9.3 Storage Precaution

# InfoVision Optoelectronics ( Kunshan ) Co.,LTD.

Document Title	M101GWT9 R3 customer approved specification			Page No.	29/29
Document No.		Issue date	2016/5/20	Revision	00

- (1) Please do not leave LCD module in the environment of high humidity and high temperature for a long time.
- (2) The module shall not be exposed under strong light such as direct sunlight. Otherwise, display characteristics may be changed.
- (3) The module should be stored in a dark place. It is prohibited to apply sunlight or fluorescent light in storage.

## 9.4 Operation Precaution

- (1) Do not connect or disconnect the module in the "Power On" condition.
- (2) Power supply should always be turned on/off by "Power On/Off Sequence".
- (3) Module has high frequency circuits. Sufficient suppression to the electromagnetic interference should be done by system manufacturers. Grounding and shielding methods may be important to minimize the interference.
- (4) After installation of the TFT module into an enclosure, do not twist nor bend the TFT module even momentary. At designing the enclosure, it should be taken into consideration that no bending/twisting forces are applied to the TFT module from outside. Otherwise the TFT module may be damaged.

## 9.5 Others

- (1) Ultra-violet ray filter is necessary for outdoor operation.
- (2) Avoid condensation of water which may result in improper operation or disconnection of electrode.
- (3) If the module keeps displaying the same pattern for a long period of time, the image may be "sticked" to the screen.
- (4) This module has its circuitry PCB's on the rear side and should be handled carefully in order not to be stressed.

## 9.6 Disposal

When disposing LCD module, obey the local environmental regulations.