



Document Name	M150GNN2 R3 Customer Approval Specification			Page 1 of 24	
Document No.	A-M150GNN2-R3-468-02	Made/Revised Date	2018/01/31	Ver.	00

Customer Approval Specification

To: 苏州与来视讯科技有限公司

Product Name: M150GNN2 R3

Document Issue Date: 2017/12/19

Customer	InfoVision Optoelectronics
<u>SIGNATURE</u>	<u>SIGNATURE</u>
_____	REVIEWED BY
_____	QA
_____	_____
Please return 1 copy for your confirmation with your signature and comments.	PREPARED BY
	FAE

- Note: 1. Please contact InfoVision Company. before designing your product based on this product.
2. The information contained herein is presented merely to indicate the characteristics and performance of our products. No responsibility is assumed by IVO for any intellectual property claims or other problems that may result from application based on the module described herein.

FQ-7-30-0-009-03D



Document Name	M150GNN2 R3 Customer Approval Specification			Page 3 of 24	
Document No.	A-M150GNN2-R3-468-02	Made/Revised Date	2018/01/31	Ver.	00

CONTENTS

1.0 GENERAL DESCRIPTIONS.....	4
2.0 ABSOLUTE MAXIMUM RATINGS	6
3.0 OPTICAL CHARACTERISTICS	7
4.0 ELECTRICAL CHARACTERISTICS	10
5.0 MECHANICAL CHARACTERISTICS.....	18
6.0 RELIABILITY CONDITIONS.....	20
7.0 PACKAGE SPECIFICATION	21
8.0 LOT MARK	22
9.0 GENERAL PRECAUTION.....	23

IVO Confidential document

Document Name	M150GNN2 R3 Customer Approval Specification			Page 4 of 24	
Document No.	A-M150GNN2-R3-468-02	Made/Revised Date	2018/01/31	Ver.	00

1.0 General Descriptions

1.1 Introduction

The M150GNN2 R3 is a Color Active Matrix Liquid Crystal Display with a back light system. The matrix uses a-Si Thin Film Transistor as a switching device. This TFT LCD has a 15.0 inch diagonally measured active display area with XGA resolution (1,024 horizontal by 768 vertical pixels array).

1.2 Features

- Supported XGA Resolution
- LVDS Interface
- Compatible with RoHS Standard

1.3 Product Summary

Items	Specifications	Unit
Screen Diagonal	15.0	inch
Active Area (H x V)	304.13 x 228.10	mm
Number of Pixels (H x V)	1,024 x 768	-
Pixel Pitch (H x V)	0.2970 x 0.2970	mm
Pixel Arrangement	R.G.B. Vertical Stripe	-
Display Mode	Normally White	-
White Luminance	420 (Typ.)	cd /m ²
Contrast Ratio	800(Typ.)	-
Response Time	16 (Typ.)	ms
Input Voltage	3.3 (Typ.)	V
Power Consumption	8.8(Max)	W
Weight	1200(Max.)	g
Outline Dimension (H x V x D)	326.50(Typ.) x 253.50(Typ.) x 12.50(Max)	mm
Electrical Interface (Logic)	LVDS	-
Support Color	16.2 M	-
NTSC	70 (Typ.)	%
Viewing Direction	6 O'clock	-
Surface Treatment	AG+3H	-

Document Name	M150GNN2 R3 Customer Approval Specification	Page 5 of 24			
Document No.	A-M150GNN2-R3-468-02	Made/Revised Date	2018/01/31	Ver.	00

1.4 Functional Block Diagram

Figure 1 shows the functional block diagram of the LCD module.

Figure 1 Block Diagram

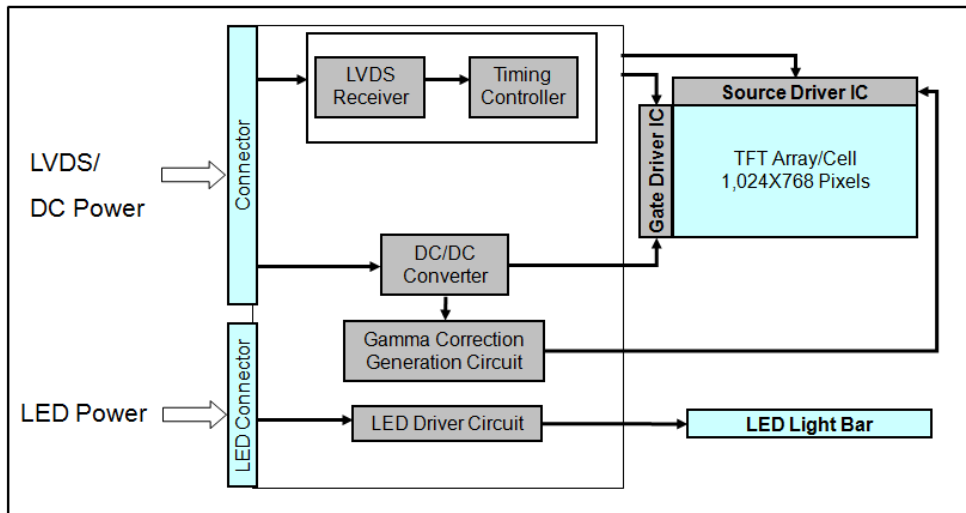

1.5 Pixel Mapping

Figure 2 Pixel Mapping

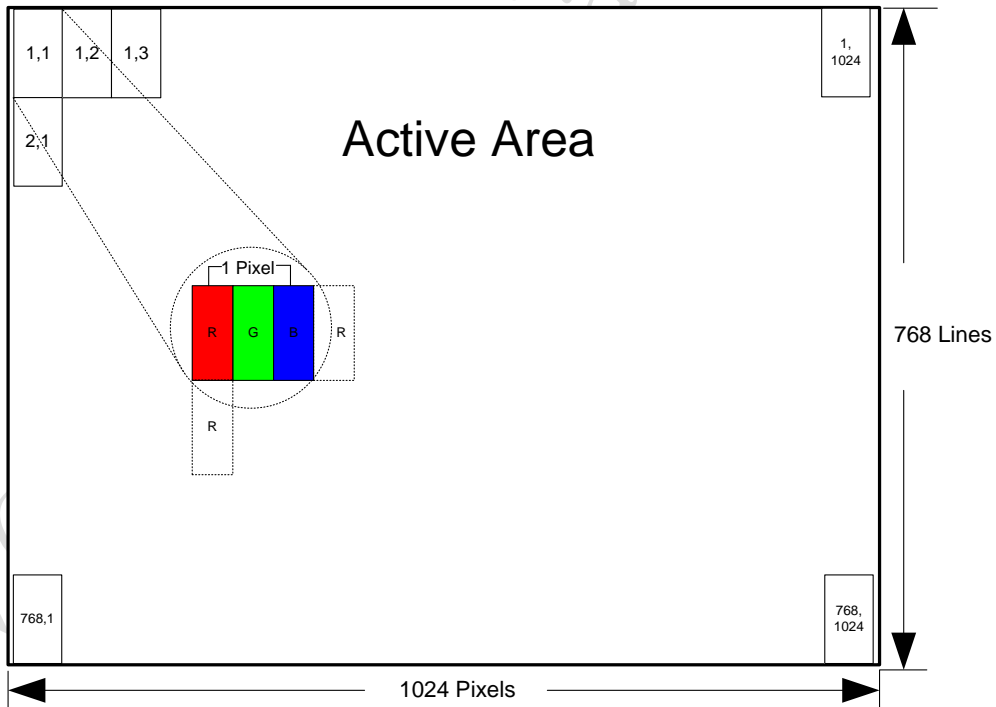

Document Name	M150GNN2 R3 Customer Approval Specification			Page 6 of 24	
Document No.	A-M150GNN2-R3-468-02	Made/Revised Date	2018/01/31	Ver.	00

2.0 Absolute Maximum Ratings

Table 1 Electrical & Environment Absolute Rating

Item	Symbol	Min.	Max.	Unit	Note
Logic Supply Voltage	V_{DD}	-0.5	5	V	(1),(2),(3),(4)
Operating Temperature	T_{gs}	-10	65	°C	
Storage Temperature	T_a	-20	70	°C	

Note (1) All the parameters specified in the table are absolute maximum rating values that may cause faulty operation or unrecoverable damage, if exceeded. It is recommended to follow the typical value.

Note (2) All the contents of electro-optical specifications and display fineness are guaranteed under Normal Conditions. All the display fineness should be inspected under normal conditions. Normal conditions are defined as follow: Temperature: 25°C, Humidity: 55± 10%RH.

Note (3) Unpredictable results may occur when it was used in extreme conditions. T_a = Ambient Temperature, T_{gs} = Glass Surface Temperature. All the display fineness should be inspected under normal conditions.

Note (4) Temperature and relative humidity range are shown in the figure below. Wet bulb temperature should be lower than 39°C, and no condensation of water. Besides, protect the module from static electricity.

Figure 3 Absolute Ratings of Environment of the LCD Module

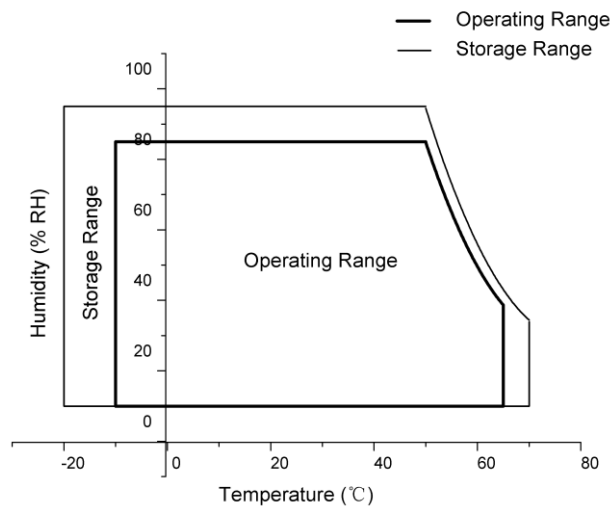

Document Name	M150GNN2 R3 Customer Approval Specification			Page 7 of 24	
Document No.	A-M150GNN2-R3-468-02	Made/Revised Date	2018/01/31	Ver.	00

3.0 Optical Characteristics

The optical characteristics are measured under stable conditions as following notes.

Table 2 Optical Characteristics

Item	Conditions	Min.	Typ.	Max.	Unit	Note
Viewing Angle (CR≥10)	Horizontal	θ_{x+}	70	80	-	degree (1),(2),(3),(4),(7)
		θ_{x-}	70	80	-	
	Vertical	θ_{y+}	70	80	-	
		θ_{y-}	60	80	-	
Contrast Ratio	Center	450	800	-	-	(1),(2),(4),(7) $\theta_x=\theta_y=0^\circ$
Response Time	Rising + Falling	-	16	25	ms	(1),(2),(5),(7) $\theta_x=\theta_y=0^\circ$
Color Chromaticity (CIE1931)	Red x	- Typ. -0.03	0.625	Typ. +0.03-	-	(1),(2),(3),(7) $\theta_x=\theta_y=0^\circ$
	Red y		0.352		-	
	Green x		0.315		-	
	Green y		0.630		-	
	Blue x		0.149		-	
	Blue y		0.067		-	
	White x	0.255	0.305	0.355	-	
	White y	0.275	0.325	0.375	-	
NTSC	-	65	70	-	%	(1),(2),(3),(7) $\theta_x=\theta_y=0^\circ$
White Luminance	Center	350	420	-	cd/m ²	(1),(2),(7) $\theta_x=\theta_y=0^\circ$
Luminance Uniformity	9 Points	75	80	-	%	(1),(2),(6),(7) $\theta_x=\theta_y=0^\circ$

Note (1) Measurement Setup:

The LCD module should be stabilized at given ambient temperature (25°C) for 30 minutes to avoid abrupt temperature changing during measuring. In order to stabilize the luminance, the measurement should be executed after lighting backlight for 30 minutes in the windless room.

Document Name	M150GNN2 R3 Customer Approval Specification	Page 8 of 24			
Document No.	A-M150GNN2-R3-468-02	Made/Revised Date	2018/01/31	Ver.	00

Figure 4 Measurement Setup

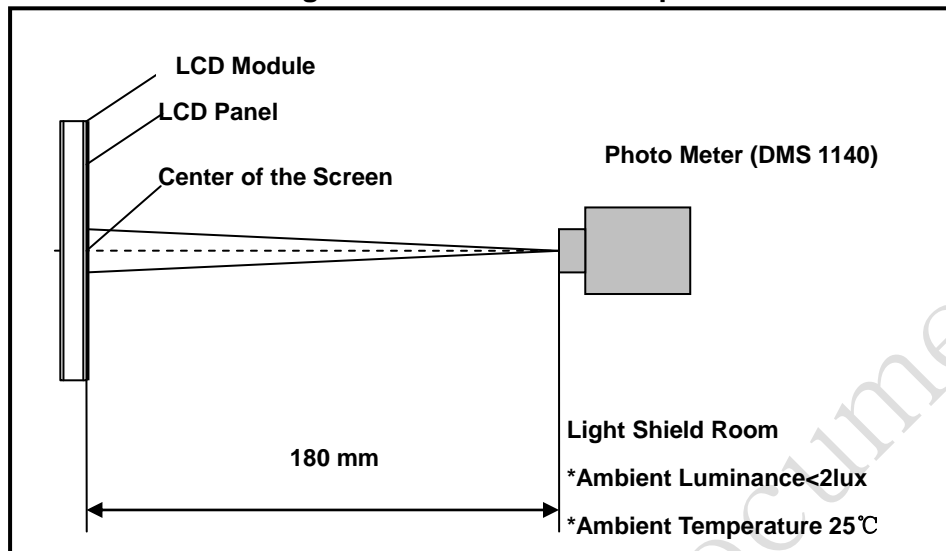

Note (2) The LED input parameter setting as:

VLED: 12V

PWM_LED: Duty 100 %

Note (3) Definition of Viewing Angle

Figure 5 Definition of Viewing Angle

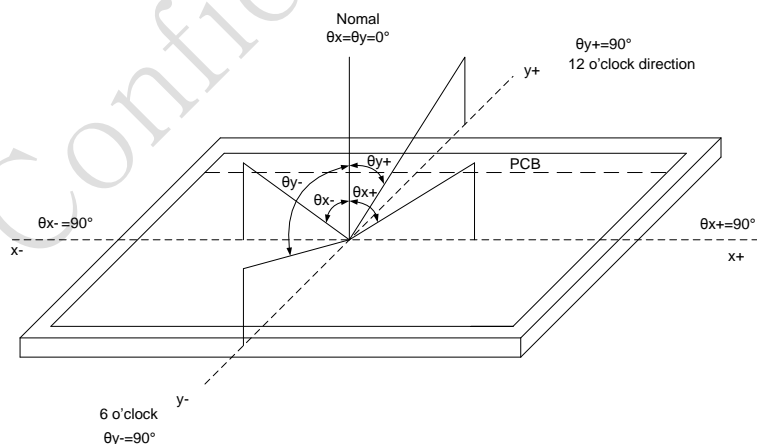

Note (4) Definition Of Contrast Ratio (CR)

The contrast ratio can be calculated by the following expression:

$$\text{Contrast Ratio (CR)} = L_{255} / L_0$$

L255: Luminance of gray level 255, L0: Luminance of gray level 0

Note (5) Definition Of Response Time (T_R , T_F)

Document Name	M150GNN2 R3 Customer Approval Specification	Page 9 of 24			
Document No.	A-M150GNN2-R3-468-02	Made/Revised Date	2018/01/31	Ver.	00

Figure 6 Definition of Response Time

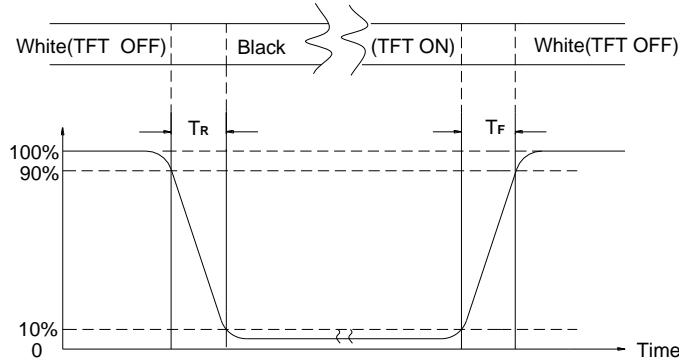

Note (6) Definition Of Luminance Uniformity (Ref.: Active Area)

Measure the luminance of gray level 255 at 9 points.

Luminance Uniformity= $\text{Min.}(L1, L2, \dots L9) / \text{Max.}(L1, L2, \dots L9)$

H—Active Area Width, V—Active Area Height, L—Luminance

Figure 7 Measurement Locations of 9 Points

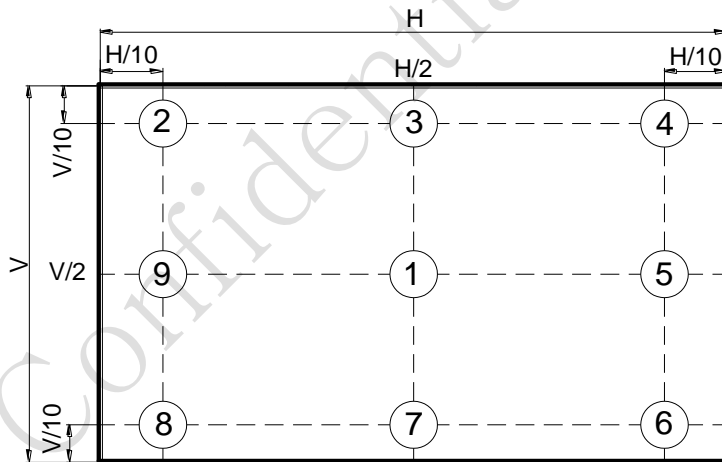

Note (7) All optical data based on IVO given system & nominal parameter & testing machine in this document.

Document Name	M150GNN2 R3 Customer Approval Specification			Page 10 of 24	
Document No.	A-M150GNN2-R3-468-02	Made/Revised Date	2018/01/31	Ver.	00

4.0 Electrical Characteristics

4.1 Interface Connector

Table 3 Signal Connector Type

Item	Description
Manufacturer / Type	MSB240420HD
Mating Receptacle / Type (Reference)	P240420 or compatible

Table 4 Signal Connector Pin Assignment

Pin No.	Symbol	Description	Remarks
1	VDD	Power Supply, 3.3V (typical)	
2	VDD	Power Supply, 3.3V (typical)	
3	VSS	Ground	
4	REV	Reverse Scan selection	Note
5	Rin1-	-LVDS differential data input (R0-R5,G0)	
6	Rin1+	+LVDS differential data input (R0-R5,G0)	
7	VSS	Ground	
8	Rin2-	-LVDS differential data input (G1-G5,B0-B1)	
9	Rin2+	+LVDS differential data input (G1-G5,B0-B1)	
10	VSS	Ground	
11	Rin3-	-LVDS differential data input (B2-B5,HS,VS,DE)	
12	Rin3+	+LVDS differential data input (B2-B5,HS,VS,DE)	
13	VSS	Ground	
14	ClkIN-	-LVDS differential clock input	
15	ClkIN+	+LVDS differential clock input	
16	GND	Ground	
17	Rin4-	-LVDS differential data input (R6-R7,G6-G7,B6-B7)	
18	Rin4+	+VDS differential data input(R6-R7,G6-G7,B6-B7)	
19	VSS	Ground	
20	NC	Not connect	

Document Name	M150GNN2 R3 Customer Approval Specification			Page 11 of 24	
Document No.	A-M150GNN2-R3-468-02	Made/Revised Date	2018/01/31	Ver.	00

Note: I REV = LOW/NC ($0 \leq \text{REV} \leq 0.8\text{V}$)

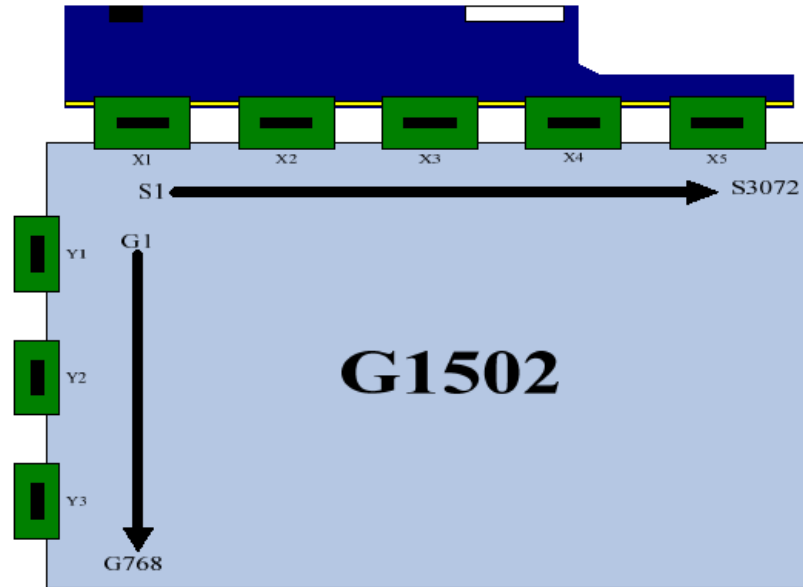

II REV = High ($2.5 \leq \text{REV} \leq 3.6\text{V}$)

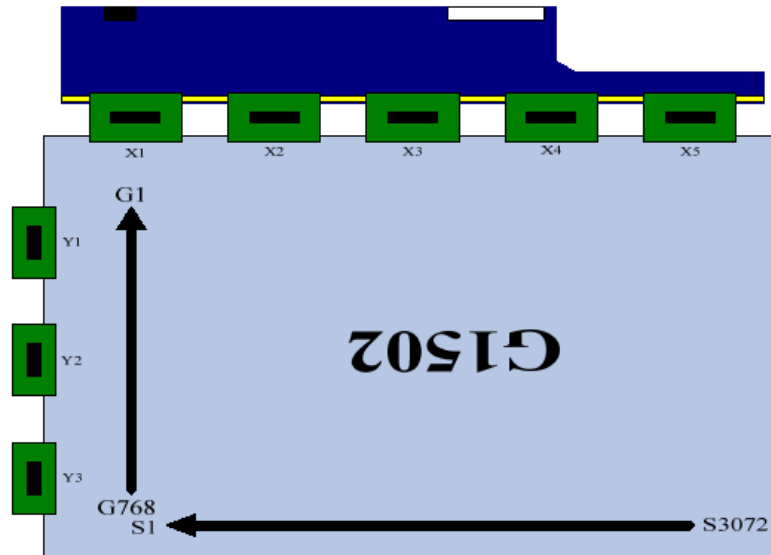

Document Name	M150GNN2 R3 Customer Approval Specification			Page 12 of 24	
Document No.	A-M150GNN2-R3-468-02	Made/Revised Date	2018/01/31	Ver.	00

Table 5 LED Connector Name / Designation

Item	Description
Connector Name/Designation	LED Driver Connector
Manufacturer	STM or compatible
Connector Model Number	MSB24038P5A or compatible
Mating Model Number	P24038P5A or compatible

Table 6 LED Connector Pin Assignment

Pin No.	Symbol	Description	Remarks
1	VLED	12V	-
2	GND	GND	-
3	Enable	5V-On / 0V-Off	-
4	Dimming	PWM Dimming	-
5	NC	NC	-

4.2 Signal Electrical Characteristics

4.2.1 Signal Electrical Characteristics For LVDS Receiver

The built-in LVDS receiver is compatible with (ANSI/TIA/TIA-644) standard.

Table 7 LVDS Receiver Electrical Characteristics

Parameter	Symbol	Min.	Typ.	Max.	Unit	Conditions
Differential Input High Threshold	V _{th}	-	-	+100	mV	V _{CM} =+1.2V
Differential Input Low Threshold	V _{tl}	-100	-	-	mV	V _{CM} =+1.2V
Magnitude Differential Input Voltage	V _{ID}	200	-	600	mV	-
Common Mode Voltage	V _{CM}	-	1.2	1.85- V _{ID} /2	V	-
Input Leakage Current	/	-10	-	10	mV	V _{CM} =+1.2V

Note (1) Input signals shall be low or Hi- resistance state when VDD is off.

Note (2) All electrical characteristics for LVDS signal are defined and shall be measured at the interface connector of LCD.

Document Name	M150GNN2 R3 Customer Approval Specification			Page 13 of 24	
Document No.	A-M150GNN2-R3-468-02	Made/Revised Date	2018/01/31	Ver.	00

Figure 8 Voltage Definitions

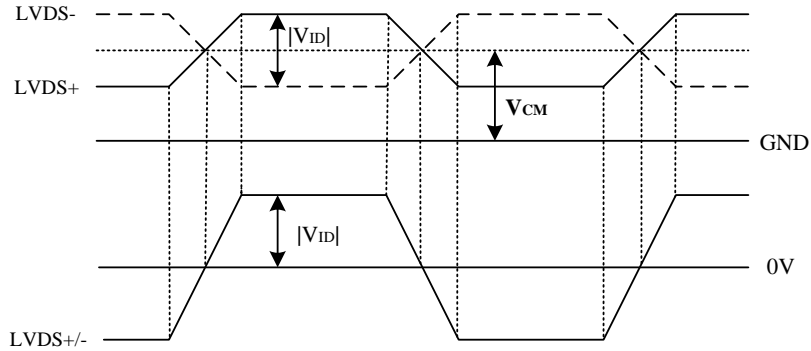

Figure 9 Measurement System

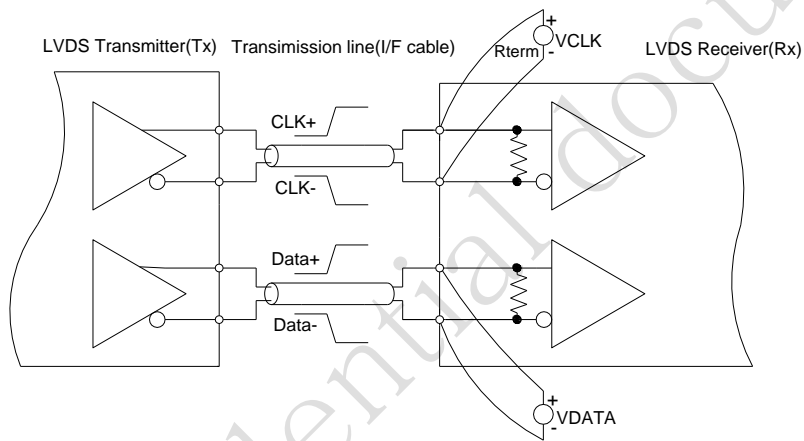
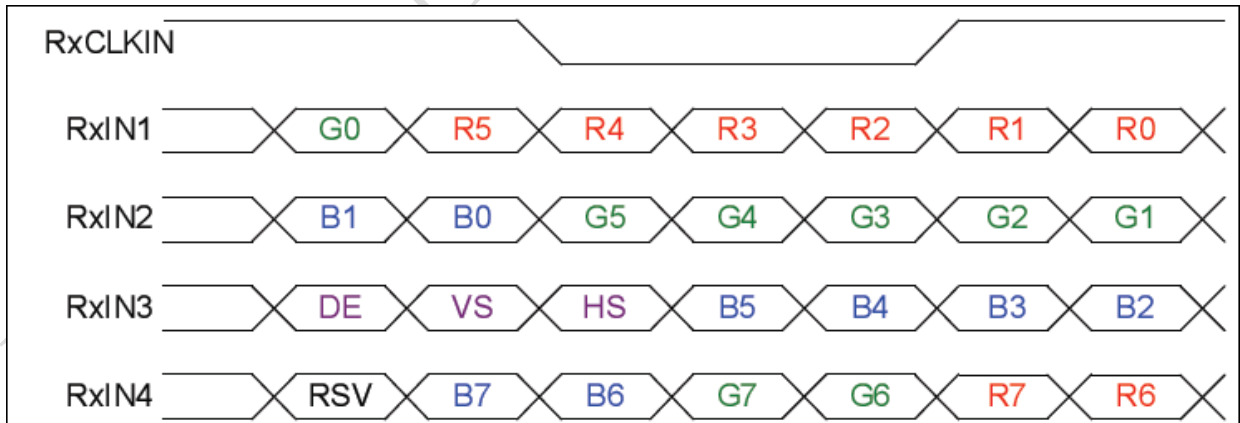

Figure 10 Data Mapping



4.2.2 LVDS Receiver Internal Circuit

Figure 11 shows the internal block diagram of the LVDS receiver. This LCD open-cell equips termination resistors for LVDS link.

Document Name	M150GNN2 R3 Customer Approval Specification			Page 14 of 24	
Document No.	A-M150GNN2-R3-468-02	Made/Revised Date	2018/01/31	Ver.	00

Figure 11 LVDS Receiver Internal Circuit

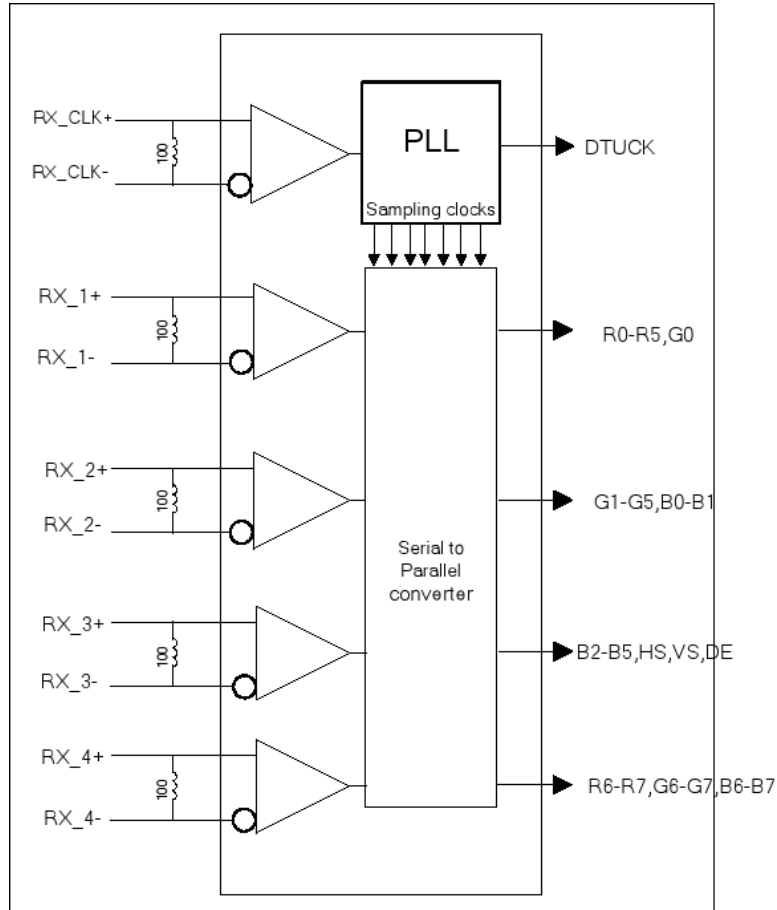

4.3 Interface Timings

Table 8 Interface Timings

Parameter	Symbol	Min.	Typ.	Max.	Unit
LVDS Clock Frequency	Fclk	50	65	80	MHz
H Total Time	HT	1,056	1,344	1,720	Clocks
H Active Time	HA	1,024	1,024	1,024	Clocks
V Total Time	VT	772	806	990	Lines
V Active Time	VA	768	768	768	Lines
Frame Rate	FV	55	60	70	Hz

Note (1) Synchronization Method: DE only

Note (2) H Blank area and V Blank area can not be changed at every frame.

Document Name	M150GNN2 R3 Customer Approval Specification				Page 15 of 24	
Document No.	A-M150GNN2-R3-468-02	Made/Revised Date	2018/01/31	Ver.	00	

4.4 Input Power Specifications

Input power specifications are as follows.

Table 9 Input Power Specifications

Parameter	Symbol	Min.	Typ.	Max.	Unit	Note	
<i>System Power Supply</i>							
LCD Drive Voltage (Logic)	V_{DD}	3.0	3.3	3.6	V	(1), (2)	
VDD Current	Black Pattern	I_{DD}	-	-	0.394	A	(1), (4)
VDD Power Consumption	Black Pattern	P_{DD}	-	-	1.3	W	
Rush Current	I_{Rush}	-	-	3	A	(1), (5)	
Allowable Logic/LCD Drive Ripple Voltage	V_{VDD-RP}	-	-	200	mV	(1)	
<i>LED Power Supply</i>							
LED Input Voltage	V_{LED}	10.8	12	12.6	V	(1), (2)	
LED Power Consumption	P_{LED}	-	-	7.5	W	(1), (5)	
LED Forward Voltage	V_F	2.8	-	3.6	V	(1), (2)	
LED Forward Current	I_F	-	60	-	mA		
PWM Signal Voltage	High	V_{PWM}	3.3	5	5.5		V
	Low		-	-	0.8		
LED Enable Voltage	High	V_{LED_EN}	2.0	5.0	5.5		V
	Low		-	-	0.8		
Input PWM Frequency	F_{PWM}	200	-	20K	Hz	(1), (2),(6)	
Duty Ratio	PWM	5	-	100	%	(1), (7)	
LED Life Time	LT	30000	-	-	Hours	(1),(8)	

Note (1) All of the specifications are guaranteed under normal conditions. Normal conditions are defined as follow: Temperature: 25°C, Humidity: 55± 10%RH.

Note (2) All of the absolute maximum ratings specified in the table, if exceeded, may cause faulty operation or unrecoverable damage. It is recommended to follow the typical value.

Note (3) The specified V_{DD} current and power consumption are measured under the $V_{DD} = 3.3 V$, $F_V = 60 Hz$ condition and Black pattern.

Note (4) The figures below is the measuring condition of V_{DD} . Rush current can be measured when T_{RUSH} is 0.5 ms.

Document Name	M150GNN2 R3 Customer Approval Specification			Page 16 of 24	
Document No.	A-M150GNN2-R3-468-02	Made/Revised Date	2018/01/31	Ver.	00

Figure 12 V_{DD} Rising Time

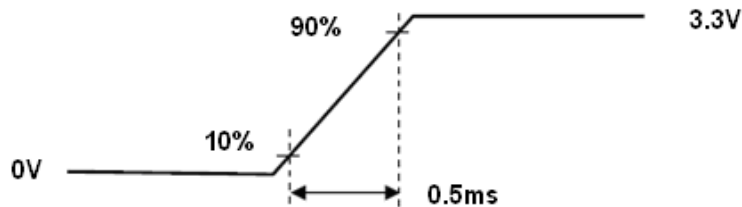

Note (5) The power consumption of LED Driver are under the $V_{LED} = 12.0V$, Dimming of Max luminance.

Note (6) Although acceptable range as defined, the dimming ratio is not effective at all conditions. The PWM frequency should be fixed and stable for more consistent luminance control at any specific level desired.

Note (7) The operation of LED Driver below minimum dimming ratio may cause flickering or reliability issue.

Note (8) The life time is determined as the sum of the lighting time till the luminance of LCD at the typical LED current reducing to 50% of the minimum value under normal operating condition.

4.5 Power ON/OFF Sequence

Interface signals are also shown in the chart. Signals from any system shall be Hi- resistance state or low level when VDD voltage is off.

Figure 13 Power Sequence

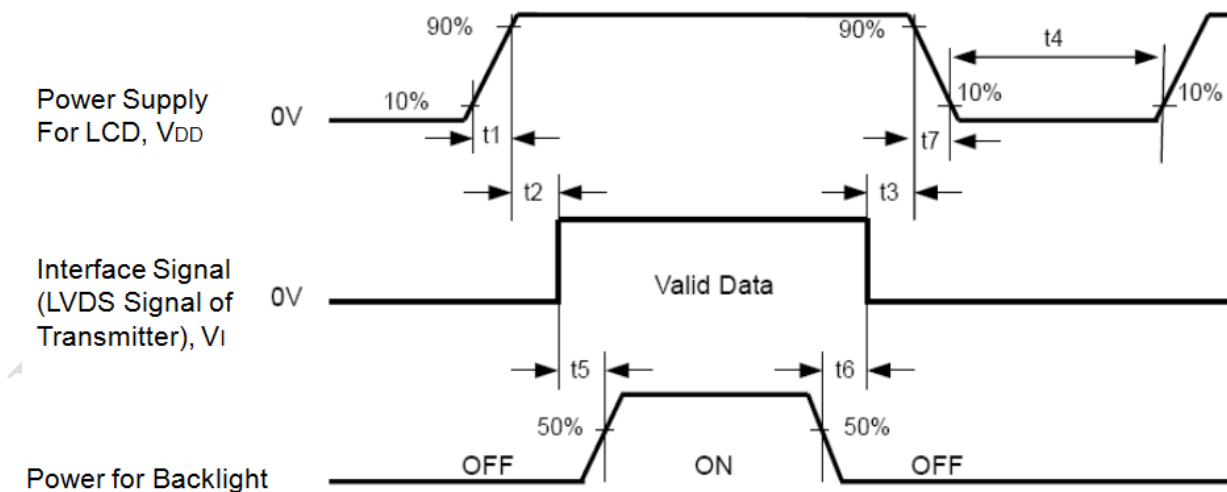

Table 10 Power Sequencing Requirements



Document Name	M150GNN2 R3 Customer Approval Specification			Page 17 of 24	
Document No.	A-M150GNN2-R3-468-02	Made/Revised Date	2018/01/31	Ver.	00

Parameter	Symbol	Min.	Typ.	Max.	Unit
VDD Rise Time	T1	0.5	-	10	ms
VDD Good to Signal Valid	T2	0	-	20	ms
Signal Disable to Power Down	T3	0	-	1000	ms
Power Off	T4	1000	-		ms
Signal Valid to Backlight On	T5	300	-		ms
Backlight Off to Signal Disable	T6	200	-		ms
VDD Fall Time	T7	0	-	100	ms

Document Name	M150GNN2 R3 Customer Approval Specification			Page 18 of 24	
Document No.	A-M150GNN2-R3-468-02	Made/Revised Date	2018/01/31	Ver.	00

5.0 Mechanical Characteristics

5.1 Outline Drawing

Figure 14 Reference Outline Drawing (Front Side)

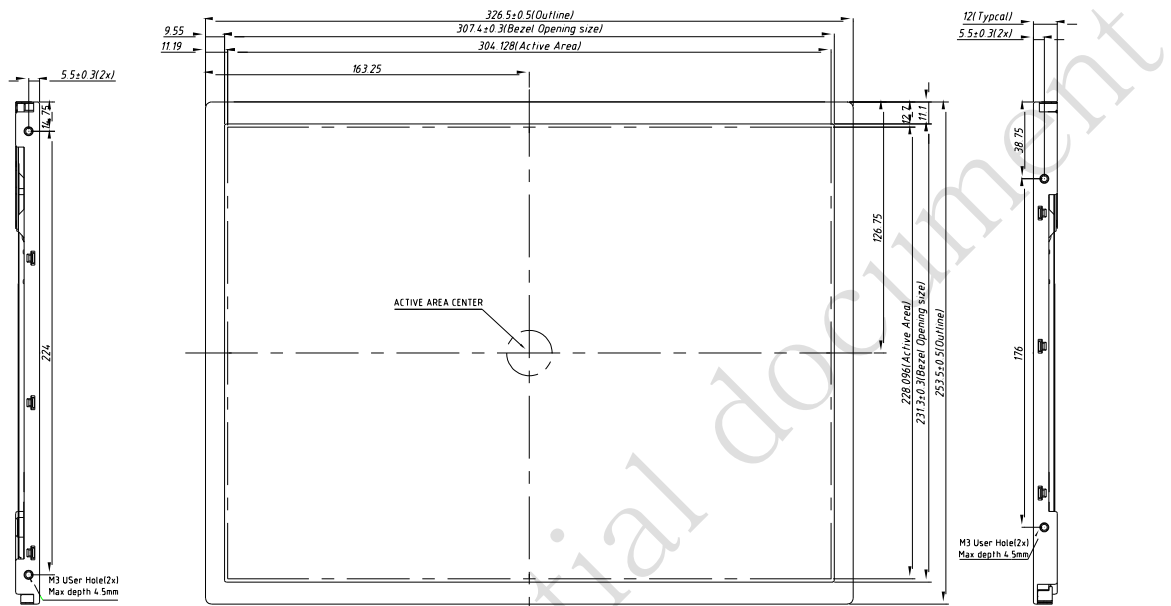
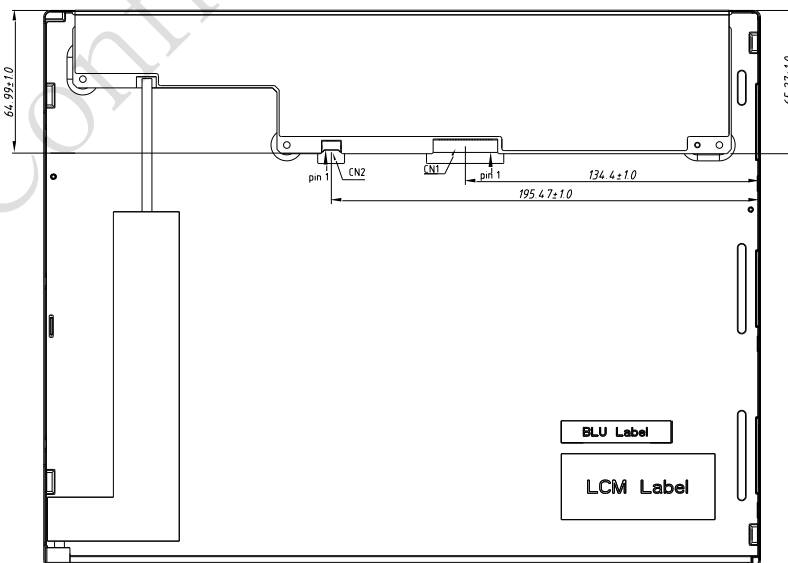

Figure 15 Reference Outline Drawing (Back Side)





Document Name	M150GNN2 R3 Customer Approval Specification			Page 19 of 24	
Document No.	A-M150GNN2-R3-468-02	Made/Revised Date	2018/01/31	Ver.	00

5.2 Dimension Specifications

Table 11 Module Dimension Specifications

Item	Min.	Typ.	Max.	Unit
Width	326.0	326.5	327.0	mm
Height	253.0	253.5	254.0	mm
Thickness	11.5	12.0	12.5	mm
Weight	-	-	1200	g

Document Name	M150GNN2 R3 Customer Approval Specification			Page 20 of 24	
Document No.	A-M150GNN2-R3-468-02	Made/Revised Date	2018/01/31	Ver.	00

6.0 Reliability Conditions

Table 12 Reliability Condition

Item	Package	Test Conditions		Note	
High Temperature Operating Test	Module	$T_{gs}=65^{\circ}\text{C}$, 500 hours		(1),(2),(3),(4)	
Low Temperature Operating Test	Module	$T_a=-10^{\circ}\text{C}$, 500 hours			
High Temperature/High Humidity Operating Test	Module	$T_{gs}=50^{\circ}\text{C}$, 85%RH, 500 hours			
Thermal Shock Non-operation Test	Module	$-20^{\circ}\text{C} \sim 70^{\circ}\text{C}$, 1hr/each cycle, 200cycles		(1),(3),(4)	
Shock Non-operating Test	Module	50G,20ms,Half Sine Wave,($\pm X, \pm Y, \pm Z$)		(1),(3),(5)	
Vibration Non-operating Test	Module	1.5G , 10~200 Hz , x、 y、 z each axis/30min			
ESD Test	Operating	Module	Contact	$\pm 8 \text{ KV}$, 150pF(330Ohm)	(1),(2),(6)
			Air	$\pm 15 \text{ KV}$, 150pF(330Ohm)	
	Non-operating		Contact	$\pm 10 \text{ KV}$, 150pF(330Ohm)	(1),(6)
			Air	$\pm 20 \text{ KV}$, 150pF(330Ohm)	

Note (1) A sample can only have one test. Outward appearance, image quality and optical data can only be checked at normal conditions according to the IVO document before reliable test. Only check the function of the module after reliability test.

Note (2) The setting of electrical parameters should follow the typical value before reliability test.

Note (3) During the test, it is unacceptable to have condensate water remains. Besides, protect the module from static electricity.

Note (4) The sample must be released for 24 hours under normal conditions before judging.

Furthermore, all the judgment must be made under normal conditions. Normal conditions are defined as follow: Temperature: 25°C , Humidity: $55 \pm 10\% \text{RH}$. T_a = Ambient Temperature, T_{gs} = Glass Surface Temperature.

Note (5) The module should be fixed firmly in order to avoid twisting and bending.

Note (6) It could be regarded as pass, when the module recovers from function fault caused by ESD after resetting.

Document Name	M150GNN2 R3 Customer Approval Specification			Page 21 of 24	
Document No.	A-M150GNN2-R3-468-02	Made/Revised Date	2018/01/31	Ver.	00

7.0 Package Specification

Figure 17 Packing Method

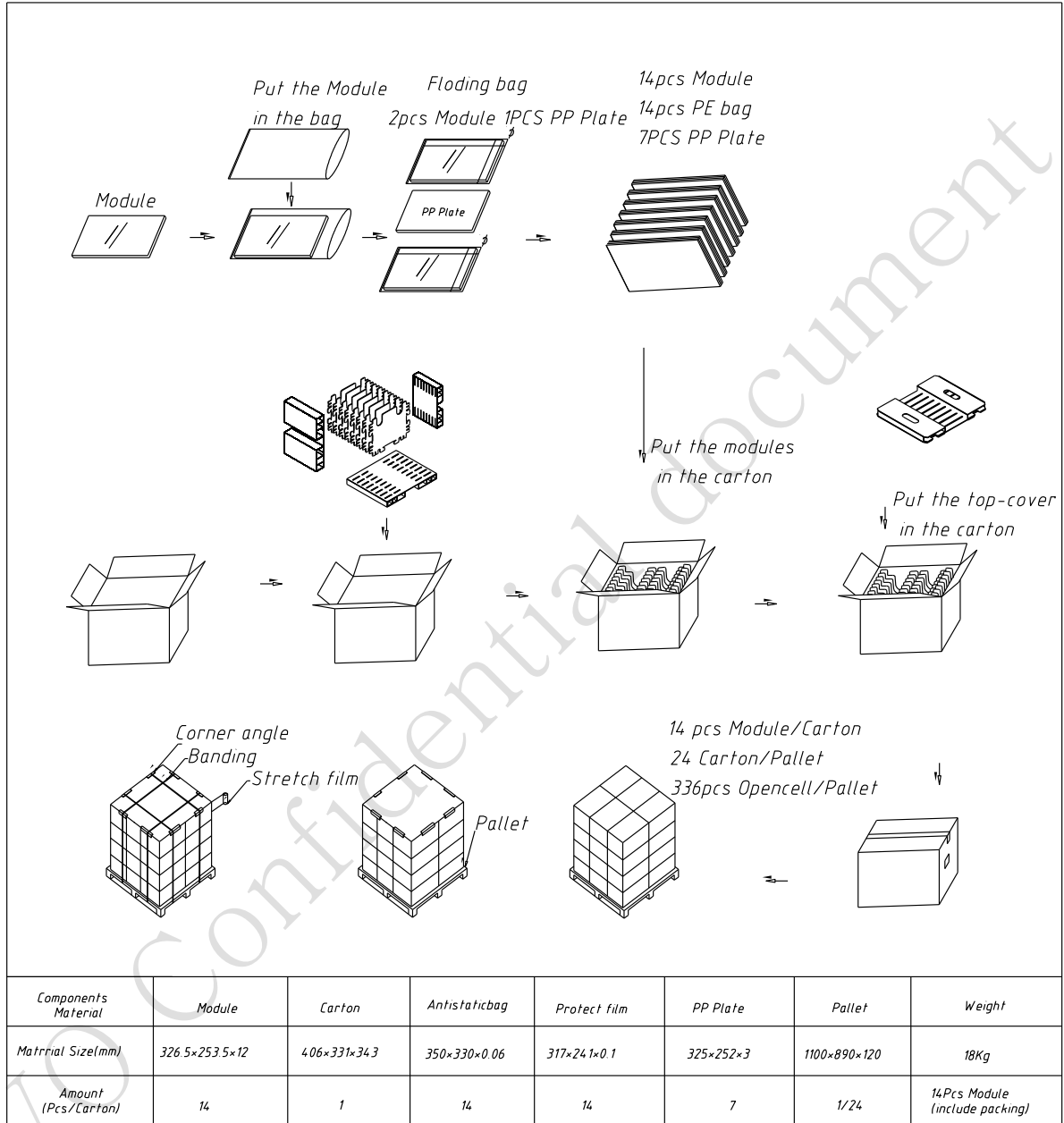

Document Name	M150GNN2 R3 Customer Approval Specification			Page 22 of 24	
Document No.	A-M150GNN2-R3-468-02	Made/Revised Date	2018/01/31	Ver.	00

8.0 Lot Mark

The diagram shows a rectangular label with the following text and markings:

- Module name:** IVO M150GNN2
- Development product name:** Z1S0EIG1502AA0410005
- 23 Product code Overseas:** MD15211ACCKS1KS1AA40005
- Lot mark:** S
- Other markings: RoHS R3, HW:1.1, FW:0.0, ZB, MADE IN CHINA, and CE 309667 US.

Note: This picture is only an example.

8.1 20 Lot Mark

1	2	3	4	5	6	7	8	9	10	11	12	13	14	15	16	17	18	19	20
---	---	---	---	---	---	---	---	---	----	----	----	----	----	----	----	----	----	----	----

Code 1,2,4,5,6,7,8,9,10,11,16: IVO internal flow control code.

Code 3: Production Location.

Code 12: Production Year.

Code 13: Production Month.

Code 14,15: Production Day.

Code 17,18,19,20: Serial Number.

8.2 23 Product Barcode

1	2	3	4	5	6	7	8	9	10	11	12	13	14	15	16	17	18	19	20	21	22	23
---	---	---	---	---	---	---	---	---	----	----	----	----	----	----	----	----	----	----	----	----	----	----

Code 1,2: Manufacture District.

Code 3,4,5,6,7: IVO internal module name.

Code 8,9,10,13,16: IVO internal flow control code.

Code 11,12: Cell location Suzhou, China defined as "KS".

Code 14,15: Module location Kunshan, China defined as "KS"; Yangzhou, China defined as "YZ"; Shenzhen, China defined as "SE"; Zhuhai, China defined as "ZH"; Suzhou, China defined as "SZ".

Code 17,18,19 : Year, Month, Day refer to Note(1), Note(2) and Note(3).

Note (1) Production Year

Year	2006	2007	2008	2009	2010	2011	2012	2013	2035
Mark	6	7	8	9	A	B	C	D	Z

Note (2) Production Month

Month	Jan.	Feb.	Mar.	Apr.	May.	Jun.	Jul.	Aug.	Sep.	Oct	Nov.	Dec.
Mark	1	2	3	4	5	6	7	8	9	A	B	C

Document Name	M150GNN2 R3 Customer Approval Specification			Page 23 of 24	
Document No.	A-M150GNN2-R3-468-02	Made/Revised Date	2018/01/31	Ver.	00

Note (3) Production Day: 1~V.
Code 20~23 : Serial Number.

9.0 General Precaution

9.1 Using Restriction

This product is not authorized for using in life supporting systems, aircraft navigation control systems, military systems and any other appliance where performance failure could be life-threatening or lead to be catastrophic.

9.2 Operation Precaution

(1)The LCD product should be operated under normal conditions.

Normal condition is defined as below:

Temperature: 25°C

Humidity: 55±10%

Display pattern: continually changing pattern (Not stationary)

(2) Brightness and response time depend on the temperature. (It needs more time to reach normal brightness in low temperature.)

(3) It is necessary for you to pay attention to condensation when the ambient temperature drops suddenly. Condensate water would damage the polarizer and electrical contacted parts of the module. Besides, smear or spot will remain after condensate water evaporating.

(4) If the absolute maximum rating value was exceeded, it may damage the module.

(5) Do not adjust the variable resistor located on the module.

(6) Sufficient suppression to the electromagnetic interference shall be done by system manufacturers. Grounding and shielding may be important to minimize the interference.

(7) Image sticking may occur when the module displayed the same pattern for long time.

(8) Do not connect or disconnect the module in the “power on” condition. Power supply should always be turned on/off by the “power on/off sequence”

(9) Ultra-violet ray filter is necessary for outdoor operation.

9.3 Mounting Precaution

(1) All the operators should be electrically grounded and with Ion-blown equipment turning on when mounting or handling. Dressing finger-stalls out of the gloves is important for keeping the panel clean during the incoming inspection and the process of assembly.

(2) It is unacceptable that the material of cover case contains acetic or chloric. Besides, any other material that could generate corrosive gas or cause circuit break by electro-chemical reaction is not desirable.

(3) The case on which a module is mounted should have sufficient strength so that external force is not transmitted to the module directly.

(4) It is obvious that you should adopt radiation structure to satisfy the temperature specification.

(5) So as to acquire higher luminance, the cable between the back light and the inverter of the

Document Name	M150GNN2 R3 Customer Approval Specification			Page 24 of 24	
Document No.	A-M150GNN2-R3-468-02	Made/Revised Date	2018/01/31	Ver.	00

power supply should be connected directly with a minimize length.

(6) It should be attached to the system tightly by using all holes for mounting, when the module is assembled. Be careful not to apply uneven force to the module, especially to the PCB on the back.

(7) A transparent protective film needs to be attached to the surface of the module.

(8) Do not press or scratch the polarizer exposed with anything harder than HB pencil lead. In addition, don't touch the pin exposed with bare hands directly.

(9) Clean the polarizer gently with absorbent cotton or soft cloth when it is dirty.

(10) Wipe off saliva or water droplet as soon as possible. Otherwise, it may cause deformation and fading of color.

(11) Desirable cleaners are IPA (Isopropyl Alcohol) or hexane. Do not use Ketone type materials (ex. Acetone), Ethyl alcohol, Toluene, Ethyl acid or Methyl chloride. It might permanent damage to the polarizer due to chemical reaction.

(12) Do not disassemble or modify the module. It may damage sensitive parts in the LCD module, and cause scratches or dust remains. IVO does not warrant the module, if you disassemble or modify the module.

9.4 Handling Precaution

(1) Static electricity will generate between the film and polarizer, when the protection film is peeled off. It should be peeled off slowly and carefully by operators who are electrically grounded and with Ion-blown equipment turning on. Besides, it is recommended to peel off the film from the bonding area.

(2) The protection film is attached to the polarizer with a small amount of glue. When the module with protection film attached is stored for a long time, a little glue may remain after peeling.

(3) If the liquid crystal material leaks from the panel, keep it away from the eyes and mouth. In case of contact with hands, legs or clothes, it must be clean with soap thoroughly.

9.5 Storage Precaution

When storing modules as spares for long time, the following precautions must be executed.

(1) Store them in a dark place. Do not expose to sunlight or fluorescent light. Keep the temperature between 5°C and 35°C at normal humidity.

(2) The polarizer surface should not come in contact with any other object. It is recommended that they be stored in the container in which they were shipped.

(3) It is recommended to use it in a short-time period, after it's unpacked. Otherwise, we would not guarantee the quality.

9.6 Others

When disposing LCD module, obey the local environmental regulations.