

Document Title	M121GNS3 R0 Customer Approved Specification			Page No.	1/25
Document No.	A- M121GNS3-R0-468-02	Issue date	2018/08/22	Revision	00

Customer Approved Specification

To: 苏州与来视讯科技有限公司

Product Name: M121GNS3 R0

Document Issue Date: 2018/08/22

Customer	InfoVision Optoelectronics
<p><u>SIGNATURE</u></p> <p>_____</p> <p>_____</p> <p>_____</p> <p>Please return 1 copy for your confirmation with your signature and comments.</p>	<p><u>SIGNATURE</u></p> <p>REVIEWED BY CQM</p> <p>_____</p> <p>PREPARED BY FAE</p> <p>_____</p>

Note: 1. Please contact InfoVision Company before designing your product based on this product.

2. The information contained herein is presented merely to indicate the characteristics and performance of our products. No responsibility is assumed by IVO for any intellectual property claims or other problems that may result from application based on the module described herein.

FQ-7-30-0-009-03D

Document Title	M121GNS3 R0 Customer Approved Specification			Page No.	3/25
Document No.	A- M121GNS3-R0-468-02	Issue date	2018/08/22	Revision	00

CONTENTS

1.0	GENERAL DESCRIPTIONS	4
2.0	ABSOLUTE MAXIMUM RATINGS	6
3.0	OPTICAL CHARACTERISTICS	7
4.0	ELECTRICAL CHARACTERISTICS	10
6.0	RELIABILITY CONDITIONS	21
7.0	PACKAGE SPECIFICATION	22
8.0	LOT MARK	23
9.0	GENERAL PRECAUTION	24

Document Title	M121GNS3 R0 Customer Approved Specification			Page No.	4/25
Document No.	A- M121GNS3-R0-468-02	Issue date	2018/08/22	Revision	00

1.0 General Descriptions

1.1 Introduction

The M121GNS3 R0 is a Color Active Matrix Liquid Crystal Display with a back light system. The matrix uses a-Si Thin Film Transistor as a switching device. This TFT LCD has a 12.1 inch diagonally measured active display area with SVGA resolution (800 horizontal by 600 vertical pixels array).

1.2 Features

- Supported SVGA Resolution
- LVDS Interface
- Compatible with RoHS Standard

1.3 Product Summary

Items	Specifications	Unit
Screen Diagonal	12.1	inch
Active Area (H x V)	246.00x184.50	mm
Number of Pixels (H x V)	800 x 600	-
Pixel Pitch (H x V)	0.3075 x 0.3075	mm
Pixel Arrangement	R.G.B. Vertical Stripe	-
Display Mode	Normally White	-
White Luminance	(400) (Typ.)	cd /m ²
Contrast Ratio	(800) (Typ.)	-
Response Time	TBD (Typ.)	ms
Input Voltage	(3.3) (Typ.)	V
Power Consumption	(6.16) (Max.) @ Black pattern, FV=(60)Hz	W
Weight	(665)(Max.)	g
Outline Dimension (H x V x D)	(276.00) (Typ.) x (209.00) (Typ.) x (9.10) (Max.)	mm
Electrical Interface (Logic)	LVDS	-
Support Color	262 K	-
NTSC	(50) (Typ.)	%
Optimum Viewing Direction	6 O'clock	-
Surface Treatment	Anti-glare,3H	-

Document Title	M121GNS3 R0 Customer Approved Specification			Page No.	5/25
Document No.	A- M121GNS3-R0-468-02	Issue date	2018/08/22	Revision	00

1.4 Functional Block Diagram

Figure 1 shows the functional block diagram of the LCD module.

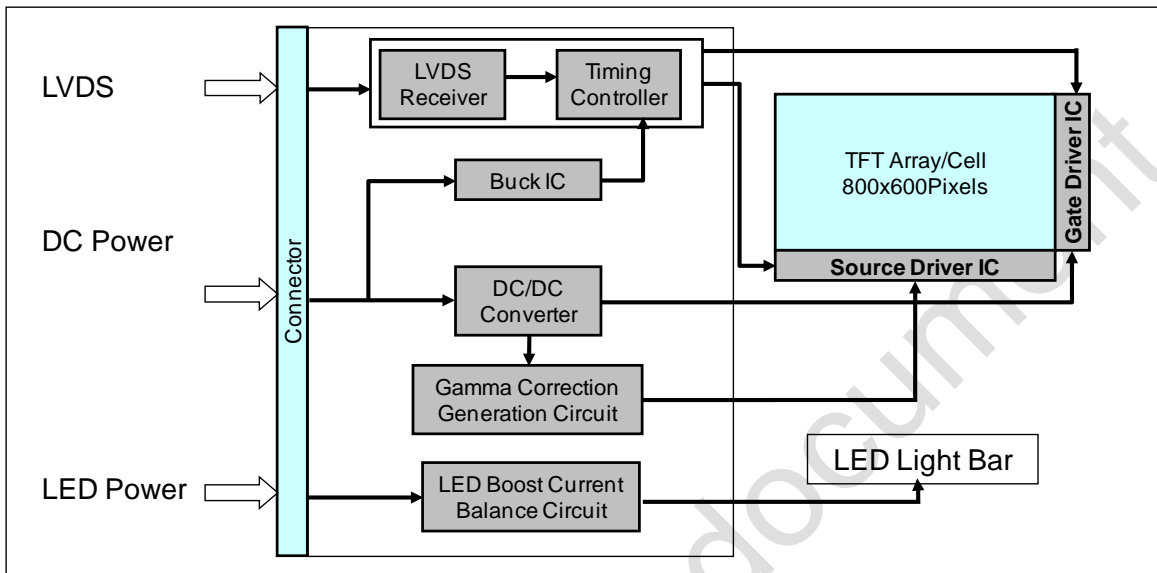

Figure 1 Block Diagram

1.5 Pixel Mapping

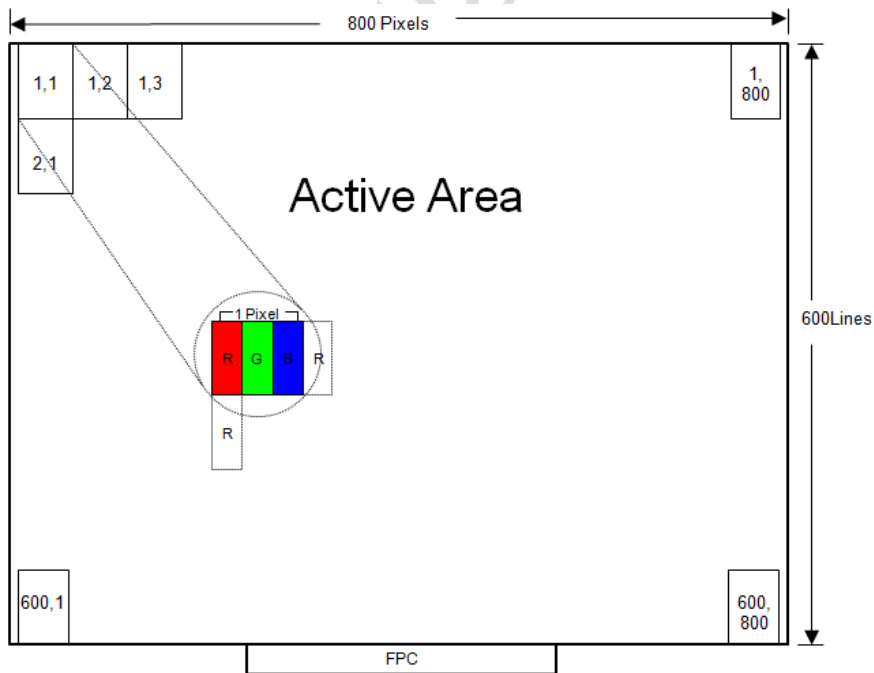

Figure 2 Pixel Mapping

Document Title	M121GNS3 R0 Customer Approved Specification			Page No.	6/25
Document No.	A- M121GNS3-R0-468-02	Issue date	2018/08/22	Revision	00

2.0 Absolute Maximum Ratings

Table 1 Electrical & Environment Absolute Rating

Item	Symbol	Min.	Max.	Unit	Note
Logic Supply Voltage	V_{cc}	(-0.3)	(4.0)	V	(1),(2), (3),(4)
Logic Input Signal Voltage	V_{Signal}	(-0)	(2.4)	V	
Operating Temperature	T_{gs}	(-20)	(70)	°C	
Storage Temperature	T_a	(-30)	(85)	°C	

Note (1) All the parameters specified in the table are absolute maximum rating values that may cause faulty operation or unrecoverable damage, if exceeded. It is recommended to follow the typical value.

Note (2) All the contents of electro-optical specifications and display fineness are guaranteed under Normal Conditions. All the display fineness should be inspected under normal conditions. Normal conditions are defined as follow: Temperature: 25°C, Humidity: 55± 10%RH.

Note (3) Unpredictable results may occur when it was used in extreme conditions. T_a = Ambient Temperature, T_{gs} = Glass Surface Temperature. All the display fineness should be inspected under normal conditions.

Note (4) Temperature and relative humidity range are shown in the figure below. Wet bulb temperature should be lower than 47°C, and no condensation of water. Besides, protect the module from static electricity.

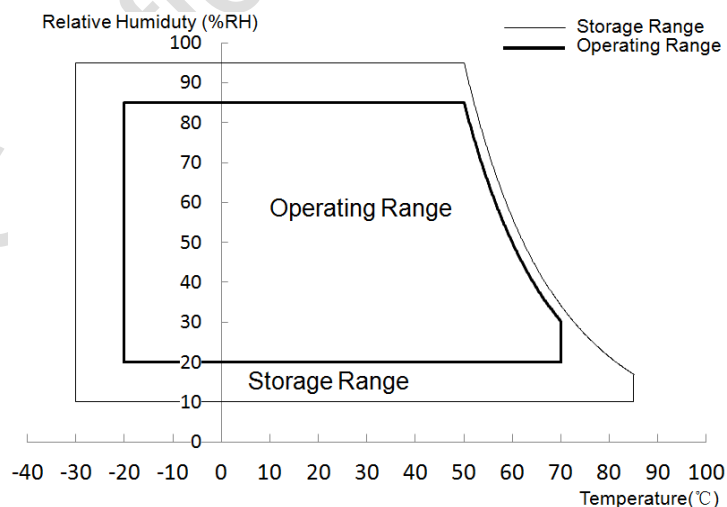

Figure 3 Absolute Ratings of Environment of the LCD Module

Document Title	M121GNS3 R0 Customer Approved Specification			Page No.	7/25
Document No.	A- M121GNS3-R0-468-02	Issue date	2018/08/22	Revision	00

3.0 Optical Characteristics

The optical characteristics are measured under stable conditions as following notes.

Table 2 Optical Characteristics

Item	Conditions	Min.	Typ.	Max.	Unit	Note		
Viewing Angle (CR≥10)	Horizontal	θ_{x+}	TBD	(80)	-	degree (1),(2),(3),(4)(8)		
		θ_{x-}	TBD	(80)	-			
	Vertical	θ_{y+}	TBD	(60)	-			
		θ_{y-}	TBD	(80)	-			
Contrast Ratio	Center	(650)	(800)	-	-	(1),(2),(4),(8) $\theta_x=\theta_y=0^\circ$		
Response Time	Rising + Falling	-	TBD	(30)	ms	(1),(2),(5),(8) $\theta_x=\theta_y=0^\circ$		
Color Chromaticity (CIE1931)	Red x	Typ. -0.03	(0.561)	Typ. +0.03	-	(1),(2),(3),(8) $\theta_x=\theta_y=0^\circ$		
	Red y		(0.327)		-			
	Green x		(0.347)		-			
	Green y		(0.590)		-			
	Blue x		(0.160)		-			
	Blue y		(0.084)		-			
	White x		(0.263)		(0.313)		(0.363)	-
	White y		(0.279)		(0.329)		(0.379)	-
NTSC	-	TBD	(50)	-	%	(1),(2),(3),(8) $\theta_x=\theta_y=0^\circ$		
White Luminance	Center Point	(300)	(400)	-	cd/m ²	(1),(2),(6),(8) $\theta_x=\theta_y=0^\circ$		
Luminance Uniformity	5 Points	(75)	-	-	%	(1),(2),(7),(8) $\theta_x=\theta_y=0^\circ$		

Note (1) Measurement Setup:

The LCD module should be stabilized at given ambient temperature (25°C) for 30 minutes to avoid abrupt temperature changing during measuring. In order to stabilize the luminance, the measurement should be executed after lighting backlight for 30 minutes in the windless room.

Document Title	M121GNS3 R0 Customer Approved Specification	Page No.	8/25
Document No.	A- M121GNS3-R0-468-02	Issue date	2018/08/22
		Revision	00

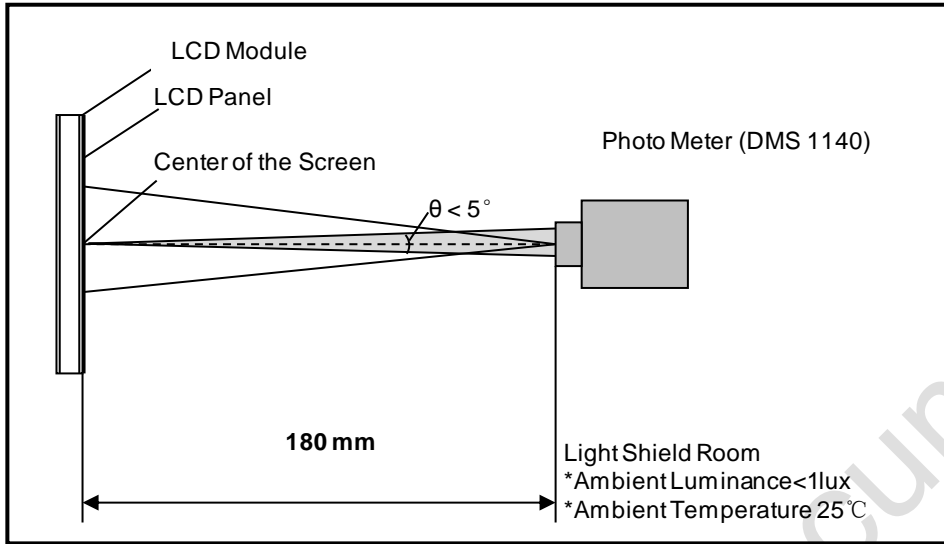

Figure 4 Measurement Setup

Note (2) The LED input parameter setting as:

V_{LED} : (12)V

PWM_LED: Duty 100 %

Note (3) Definition of Viewing Angle

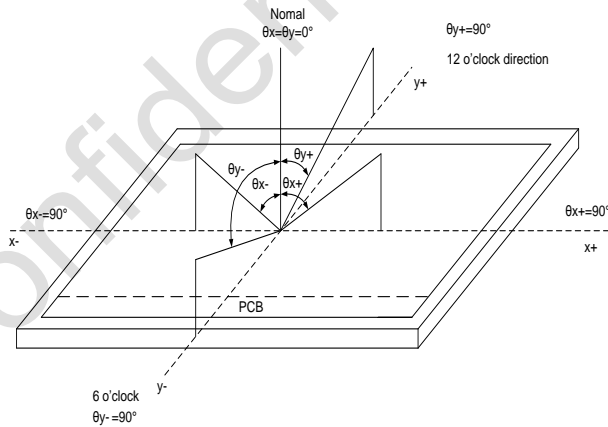

Note (4) Definition of Contrast Ratio (CR)

The contrast ratio can be calculated by the following expression:

Contrast Ratio (CR) = The luminance of White pattern/ The luminance of Black pattern

Document Title	M121GNS3 R0 Customer Approved Specification			Page No.	9/25
Document No.	A- M121GNS3-R0-468-02	Issue date	2018/08/22	Revision	00

Note (5) Definition of Response Time (T_R , T_F)

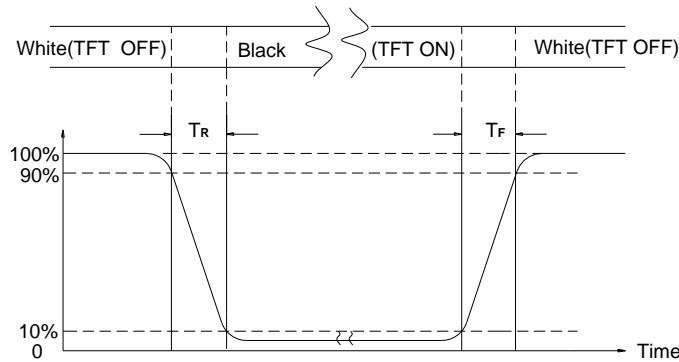

Figure 5 Definition of Response Time

Note (6) Definition of Luminance of White

Measure the luminance of White pattern (Ref.: Active Area)

Display Luminance=L1 (center point)

H—Active Area Width, V—Active Area Height, L—Luminance

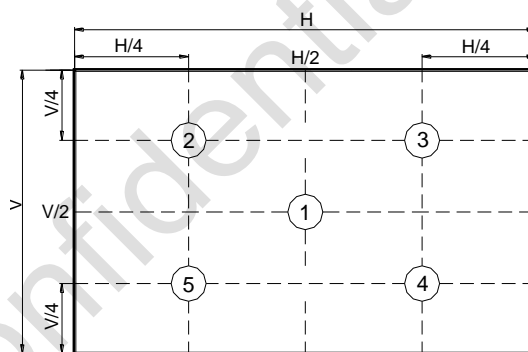

Figure 6 Measurement Locations of 5 Points

Note (7) Definition of Luminance Uniformity (Ref.: Active Area)

Measure the luminance of White pattern at 5 points.

Luminance Uniformity= $\text{Min.}(L1, L2, \dots L5) / \text{Max.}(L1, L2, \dots L5)$

H—Active Area Width, V—Active Area Height, L—Luminance

Note (8) All optical data are based on IVO given system & nominal parameter & testing machine in this document.

Document Title	M121GNS3 R0 Customer Approved Specification			Page No.	10/25
Document No.	A- M121GNS3-R0-468-02	Issue date	2018/08/22	Revision	00

4.0 Electrical Characteristics

4.1 Interface Connector

Table 3 Signal Connector Type

Item	Description
Mating Receptacle / Type (Reference)	076B20-0048RA-G4

Table 4 Signal Connector Pin Assignment

Pin No.	Symbol	Description	Remarks
1	Vcc	+3.3V Power supply	-
2	Vcc	+3.3V Power supply	-
3	GND	GND	-
4	GND	GND	-
5	RxIN0-	LVDS receiver signal CH0(-)	-
6	RxIN0+	LVDS receiver signal CH0(+)	-
7	GND	GND	-
8	RxIN1-	LVDS receiver signal CH1(-)	-
9	RxIN1+	LVDS receiver signal CH1(+)	-
10	GND	GND	-
11	RxIN2-	LVDS receiver signal CH2(-)	-
12	RxIN2+	LVDS receiver signal CH2(+)	-
13	GND	GND	-
14	CK IN-	LVDS receiver signal CK(-)	-
15	CK IN+	LVDS receiver signal CK(+)	-
16	GND	GND	-
17	NC	Non connection	-
18	RL/UD	Horizontal/Vertical Control Pin	-
19	GND	GND	-
20	GND	GND	-

Note (1) L/NC: (0~0.4)V; H: (3~3.6)V;

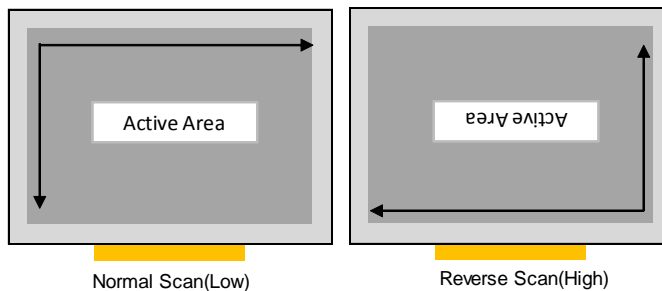

Table 5 LED Connector Name / Designation

Document Title	M121GNS3 R0 Customer Approved Specification			Page No.	11/25
Document No.	A- M121GNS3-R0-468-02	Issue date	2018/08/22	Revision	00

Item	Description
Mating Receptacle / Type (Reference)	SM06B-SHLK-G-TF (HF)

Table 6 LED Connector Pin Assignment

Pin No.	Symbol	Description	Remarks
1	VCC	Power supply(+12V)	-
2	VCC	Power supply(+12V)	-
3	GND	Ground	-
4	GND	Ground	-
5	EN_LED	LED ENABLE PIN(+3.3V INPUT)	-
6	PWM_LED	SYSTEM PWM SIGNAL INPUT	-

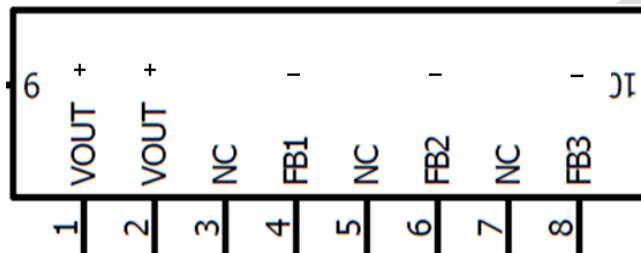

Figure 7 LED Connector

Document Title	M121GNS3 R0 Customer Approved Specification			Page No.	12/25
Document No.	A- M121GNS3-R0-468-02	Issue date	2018/08/22	Revision	00

4.2 Signal Electrical Characteristics

4.2.1 Signal Electrical Characteristics For LVDS Receiver

The built-in LVDS receiver is compatible with (ANSI/TIA/TIA-644) standard.

Table 7 LVDS Receiver Electrical Characteristics

Parameter	Symbol	Min.	Typ.	Max.	Unit	Conditions
Differential Input High Threshold	V_{th}	-	-	+100	mV	$V_{CM}=+1.2V$
Differential Input Low Threshold	V_{tl}	-100	-	-	mV	$V_{CM}=+1.2V$
Magnitude Differential Input	$ V_{ID} $	200	-	600	mV	-
Common Mode Voltage	V_{CM}	-	1.2	-	V	$V_{th}-V_{tl} = 200\text{ mV}$
Common Mode Voltage Offset	ΔV_{CM}	-50	-	50	mV	$V_{th}-V_{tl} = 200\text{ mV}$

Note (1) Input signals shall be low or Hi- resistance state when VCC is off.

Note (2) All electrical characteristics for LVDS signal are defined and shall be measured at the interface connector of LCD.

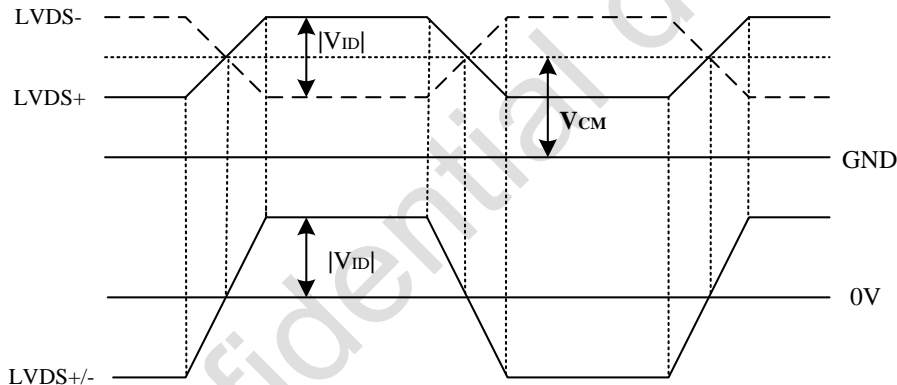

Figure 8 Voltage Definitions

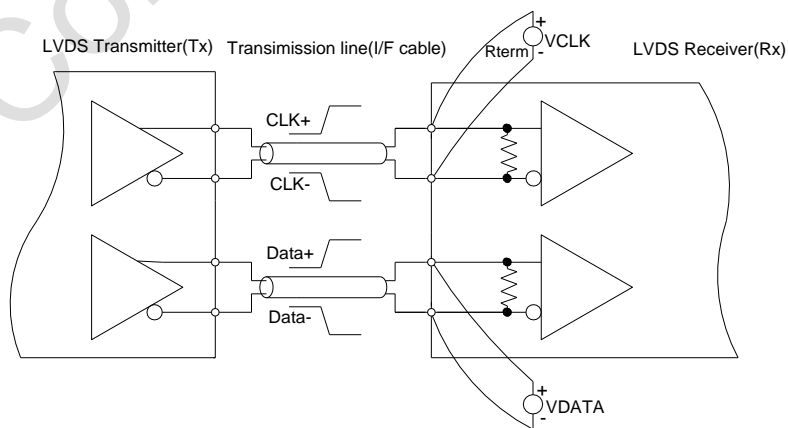

Figure 9 Measurement System

Document Title	M121GNS3 R0 Customer Approved Specification			Page No.	13/25
Document No.	A- M121GNS3-R0-468-02	Issue date	2018/08/22	Revision	00

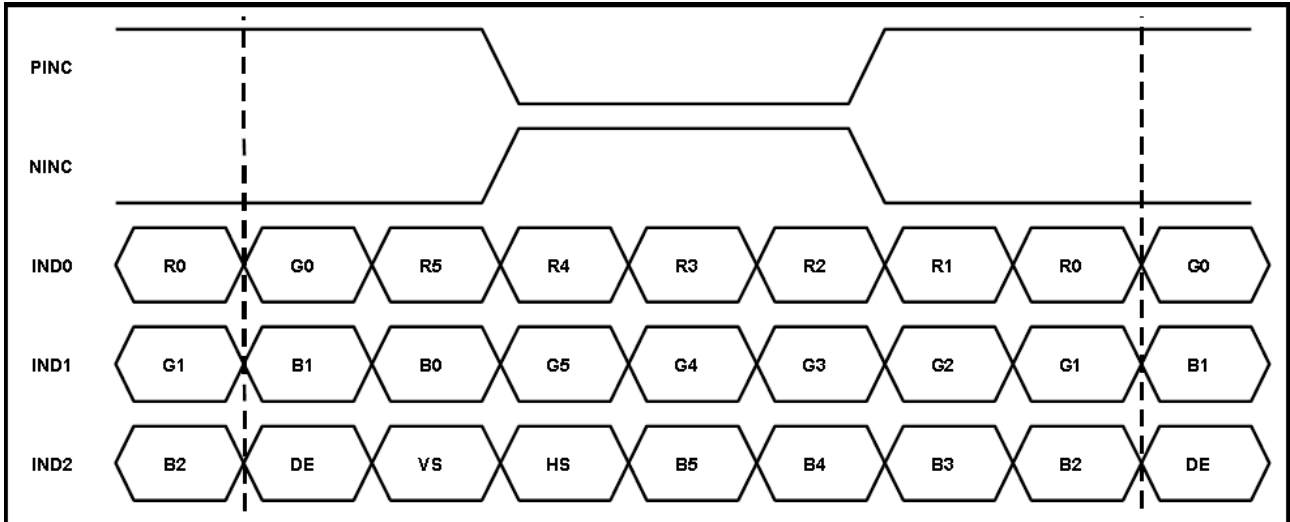

Figure 10 Data Mapping

Document Title	M121GNS3 R0 Customer Approved Specification			Page No.	14/25
Document No.	A- M121GNS3-R0-468-02	Issue date	2018/08/22	Revision	00

4.2.2 LVDS Receiver Internal Circuit

Figure 12 shows the internal block diagram of the LVDS receiver. This LCD module equips termination resistors for LVDS link.

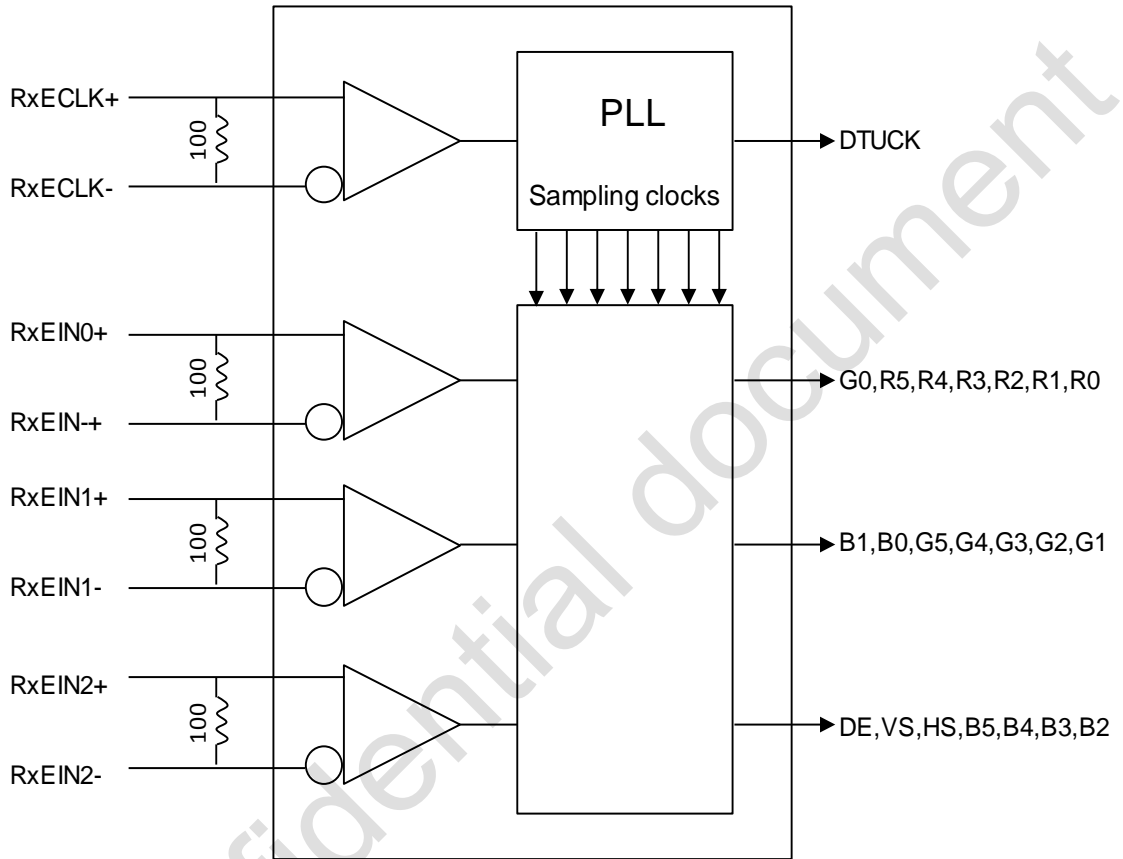

Figure 11 LVDS Receiver Internal Circuit

Document Title	M121GNS3 R0 Customer Approved Specification			Page No.	15/25
Document No.	A- M121GNS3-R0-468-02	Issue date	2018/08/22	Revision	00

4.3 Interface Timings

Table 8 Table 8 Interface Timings

Parameter	Symbol	Min.	Typ.	Max.	Unit
LVDS Clock Frequency	Fclk	(38.7)	(42.2)	(45.7)	MHz
H Total Time	HT	(940)	(1056)	(1395)	Clocks
H Active Time	HA	(800)			
V Total Time	VT	(628)	(666)	(798)	Lines
V Active Time	VA	(600)			
Frame Rate	FV	(55)	(60)	(65)	Hz

Note1: $HT * VT * \text{Frame Frequency} \leq 42.2 \text{ MHz}$

Note2: All reliabilities are specified for timing specification based on refresh rate of 60 Hz.

M121GNS3 R0 is secured only for function under lower refresh rate; 60 Hz at Normal mode, 55 Hz at Power save mode. Don't care flicker level (power save mode)

Document Title	M121GNS3 R0 Customer Approved Specification			Page No.	16/25
Document No.	A- M121GNS3-R0-468-02	Issue date	2018/08/22	Revision	00

4.4 Input Power Specifications

Input power specifications are as follows.

Table 9 Input Power Specifications

Parameter	Symbol	Min.	Typ.	Max.	Unit	Note	
<i>System Power Supply</i>							
LCD Drive Voltage (Logic)	V_{CC}	(3.0)	(3.3)	(3.6)	V	(1),(2)	
VCC Current	Black	I_{DD}	-	-	(0.35)	A	(1),(4)
VCC Power Consumption	Pattern	P_{DD}	-	-	(1.16)	W	
Logic Input Signal Voltage		V_{IH}	(3.0)	-	(3.6)	V	(1)
		V_{IL}	(0)	-	(0.4)	V	
Rush Current		I_{Rush}	-	-	(1.5)	A	(1),(4)
Allowable Logic/LCD Drive Ripple Voltage		V_{VCC-RP}	-	-	(200)	mV	(1)
<i>LED Power Supply</i>							
LED Input Voltage		V_{LED}	(10.2)	(12.0)	(13.8)	V	(1),(2),(9)
LED Power Consumption		P_{LED}	-	-	(5.0)	W	(1),(5),(9)
LED Forward Voltage		V_F	(2.7)	-	(3.2)	V	(1),(2)
LED Forward Current		I_F	-	(49.26)	-	mA	
PWM Signal Voltage	High	V_{PWM}	(3.0)	-	(3.6)	V	
	Low		(0)	-	(0.4)		
LED Enable Voltage	High	V_{LED_EN}	(3.0)	-	(3.6)	V	
	Low		(0)	-	(0.4)		
Input PWM Frequency		F_{PWM}	(200)	-	(1,000)	Hz	(1),(2),(6)
Duty Ratio		PWM	(10)	-	(100)	%	(1),(7)
LED Life Time		LT	(50,000)	-	-	Hours	(1),(8)

Note (1) All of the specifications are guaranteed under normal conditions. Normal conditions are defined as follow: Temperature: 25°C, Humidity: 55± 10%RH.

Note (2) All of the absolute maximum ratings specified in the table, if exceeded, may cause faulty operation or unrecoverable damage .It is recommended to follow the typical value.

Note (3) The specified V_{CC} current and power consumption are measured under the $V_{CC} = (3.3) V$, $FV = (60) Hz$ condition and Black pattern.

Note (4) The figures below is the measuring condition of V_{CC} . Rush current can be measured when T_{RUSH} is 0.5 ms.

Document Title	M121GNS3 R0 Customer Approved Specification			Page No.	17/25
Document No.	A- M121GNS3-R0-468-02	Issue date	2018/08/22	Revision	00

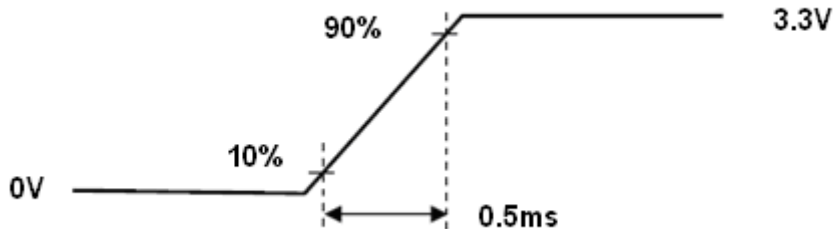

Figure 12 V_{CC} Rising Time

Note (5) The power consumption of LED Driver are under the $V_{LED} = (12) V$, Dimming of Max luminance.

Note (6) Although acceptable range as defined, the dimming ratio is not effective at all conditions. The PWM frequency should be fixed and stable for more consistent luminance control at any specific level desired.

Note (7) The operation of LED Driver below minimum dimming ratio may cause flickering or reliability issue.

Note (8) The life time is determined as the sum of the lighting time till the luminance of LCD at the typical LED current reducing to 50% of the minimum value under normal operating condition.

Document Title	M121GNS3 R0 Customer Approved Specification			Page No.	18/25
Document No.	A- M121GNS3-R0-468-02	Issue date	2018/08/22	Revision	00

4.5 Power ON/OFF Sequence

- 1.Interface signals are also shown in the chart. Signals from any system shall be Hi-resistance state or low level when VCC voltage is off.
2. When system first start up, should keep the VCC high time longer than 200ms, otherwise may cause image sticking when VCC drop off.

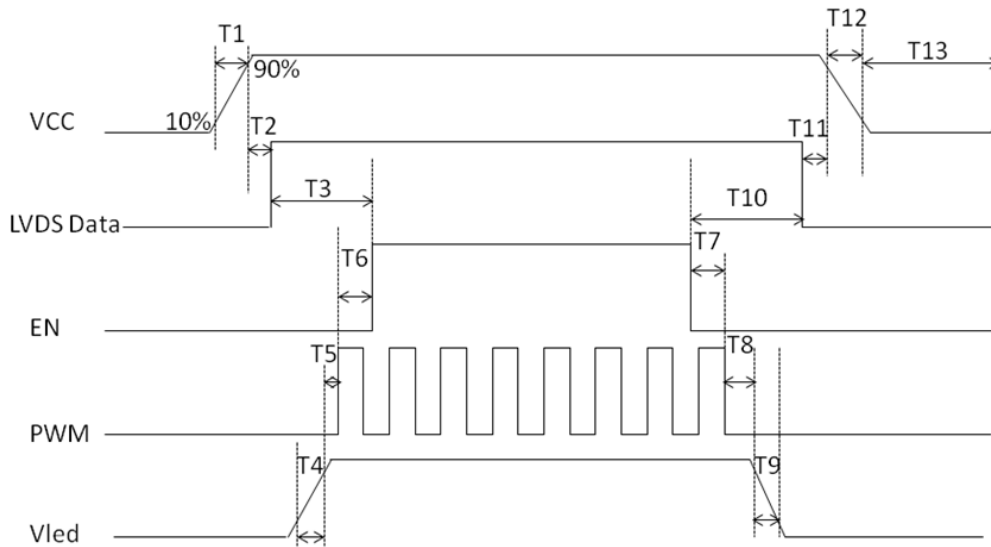

Figure 13 Power Sequence

Table 10 Power Sequencing Requirements

Parameter	Symbol	Min.	Typ.	Max.	Unit
VCC Rise Time	T1	(0.5)	-	(10)	ms
VCC Good to Signal Valid	T2	(0)	-	(50)	ms
Signal Valid to Backlight Enable On	T3	(200)	-	-	ms
Vled Power On Time	T4	(0.5)	-	(10)	ms
Vled Good to System PWM On	T5	(10)	-	-	ms
System PWM ON to Backlight Enable ON	T6	(10)	-	-	ms
Backlight Enable Off to System PWM Off	T7	(10)	-	-	ms
System PWM Off to B/L Power Disable	T8	(10)	-	-	ms
Backlight Power Off Time	T9	(0.5)	-	(30)	ms
Backlight Power Off to Signal Disable	T10	(200)	-	-	ms
Signal Disable to Power Down	T11	(0)	-	(50)	ms
VCC Fall Time	T12	(0.5)	-	(30)	ms
VCC Power Off	T13	(500)	-	-	ms

Document Title	M121GNS3 R0 Customer Approved Specification			Page No.	19/25
Document No.	A- M121GNS3-R0-468-02	Issue date	2018/08/22	Revision	00

5.0 Mechanical Characteristics

5.1 Outline Drawing

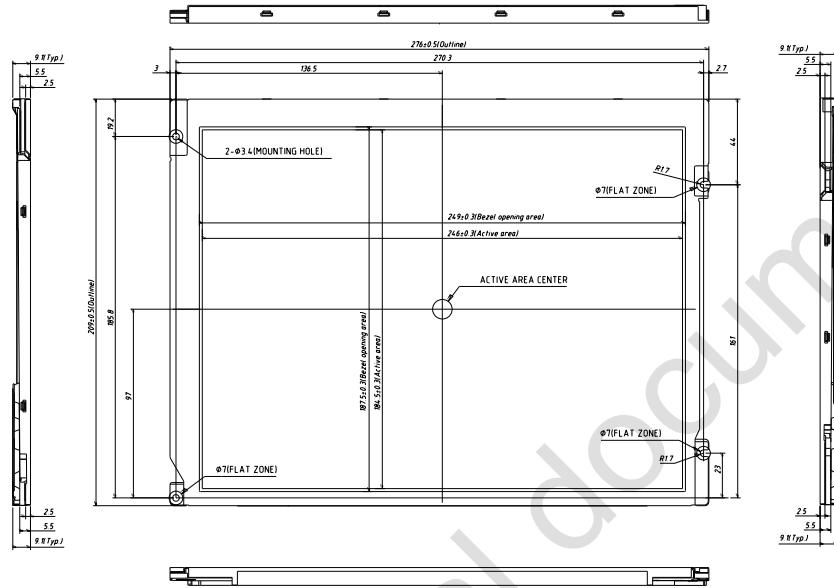

Figure 14 Reference Outline Drawing (Front Side)

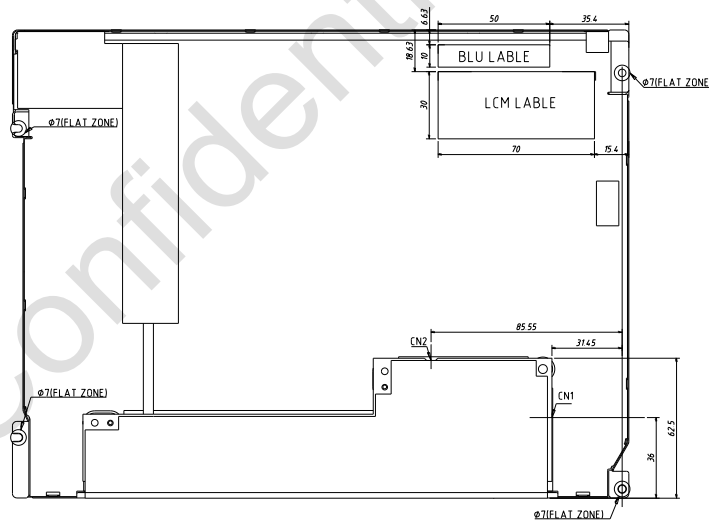

Figure 15 Reference Outline Drawing (Back Side)

Unit:mm

Note1: Unnoted tolerance $\pm 0.5\text{mm}$;

Document Title	M121GNS3 R0 Customer Approved Specification			Page No.	20/25
Document No.	A- M121GNS3-R0-468-02	Issue date	2018/08/22	Revision	00

5.2 Dimension Specifications

Table 11 Module Dimension Specifications

Item		Min.	Typ.	Max.	Unit
Width		(275.5)	(276)	(276.5)	mm
Height		(208.5)	(209)	(209.5)	mm
Thickness	With PCBA	(8.6)	(9.1)	(9.6)	mm
Weight		-	-	(665)	g

Note: Outline dimension measure instrument: Vernier Caliper.

Document Title	M121GNS3 R0 Customer Approved Specification			Page No.	21/25
Document No.	A- M121GNS3-R0-468-02	Issue date	2018/08/22	Revision	00

6.0 Reliability Conditions

Table 12 Reliability Condition

Item	Package	Test Conditions	Note	
High Temperature/High Humidity Operating Test	Module	$T_{gs}=50^{\circ}\text{C}$, 85%RH, 300 hours	(1),(2),(3),(4)	
High Temperature Operating Test	Module	$T_{gs}=70^{\circ}\text{C}$, 300 hours		
Low Temperature Operating Test	Module	$T_a=-20^{\circ}\text{C}$, 300 hours		
High Temperature Storage Test	Module	$T_a=85^{\circ}\text{C}$, 300 hours	(1),(3),(4)	
Low Temperature Storage Test	Module	$T_a=-30^{\circ}\text{C}$, 300 hours		
Shock Non-operating Test	Module	100G, 6ms, X Y Z × 2face × 3times, Total 18 times	(1),(3),(5)	
Vibration Non-operating Test	Module	half-sine, Frequency: 8Hz ~ 33Hz, Stroke: 1.3mm, Sweep: 2.9G 33.3Hz ~ 400Hz X,Z ,Cycle : 15 minutes, 2 hrs for each direction of X,Z ; 4 hours for Y direction		
ESD Test	Operating	Contact	$\pm 8\text{KV}$, 150pF(330Ohm)	(1),(2),(6)
		Air	$\pm 15\text{KV}$, 150pF(330Ohm)	
	Non-operating	Contact	$\pm 10\text{KV}$, 150pF(330Ohm)	(1),(6)
		Air	$\pm 20\text{KV}$, 150pF(330Ohm)	

Note (1) A sample can only have one test. Outward appearance, image quality and optical data can only be checked at normal conditions according to the IVO document before reliable test. Only check the function of the module after reliability test.

Note (2) The setting of electrical parameters should follow the typical value before reliability test.

Note (3) During the test, it is unaccepted to have condensate water remains. Besides, protect the module from static electricity.

Note (4) The sample must be released for 24 hours under normal conditions before judging.

Furthermore, all the judgment must be made under normal conditions. Normal conditions are defined as follow: Temperature: 25°C , Humidity: $55 \pm 10\% \text{RH}$. T_a = Ambient Temperature, T_{gs} = Glass Surface Temperature.

Note (5) The module should be fixed firmly in order to avoid twisting and bending.

Note (6) It could be regarded as pass, when the module recovers from function fault caused by ESD after resetting.

Document Title	M121GNS3 R0 Customer Approved Specification			Page No.	22/25
Document No.	A- M121GNS3-R0-468-02	Issue date	2018/08/22	Revision	00

7.0 Package Specification

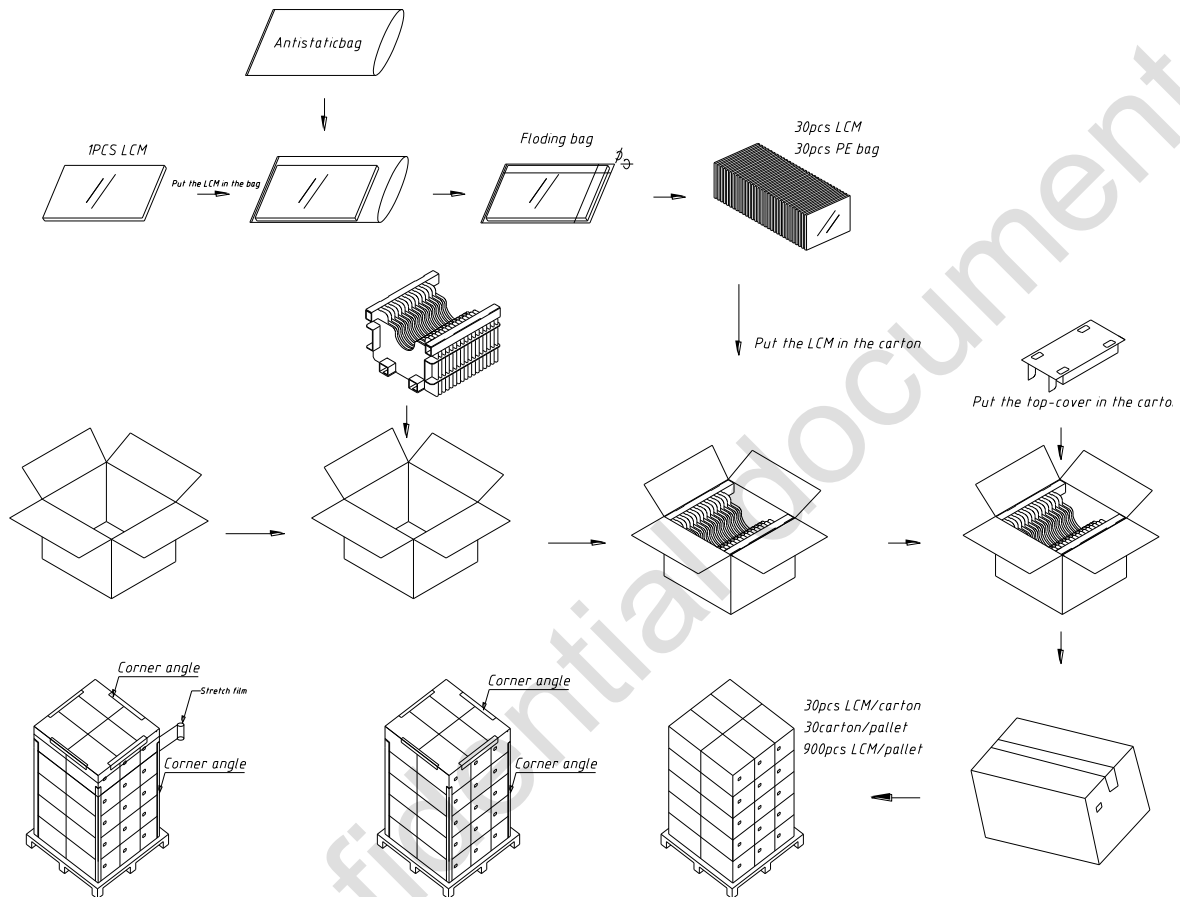

Figure 16 Packing Method

昆山龙腾光电有限公司

IVO InfoVision Optoelectronics (Kunshan) Co.,LTD.

Document Title	M121GNS3 R0 Customer Approved Specification			Page No.	23/25
Document No.	A- M121GNS3-R0-468-02	Issue date	2018/08/22	Revision	00

8.0 Lot Mark

TBD

IVO Confidential document

Document Title	M121GNS3 R0 Customer Approved Specification			Page No.	24/25
Document No.	A- M121GNS3-R0-468-02	Issue date	2018/08/22	Revision	00

9.0 General Precaution

9.1 Using Restriction

This product is not authorized for using in life supporting systems, aircraft navigation control systems, military systems and any other appliance where performance failure could be life-threatening or lead to be catastrophic.

9.2 Operation Precaution

(1)The LCD product should be operated under normal conditions.

Normal conditions are defined as below:

Temperature: 25°C

Humidity: 55±10%

Display pattern: continually changing pattern (Not stationary)

(2) Brightness and response time depend on the temperature. (It needs more time to reach normal brightness in low temperature.)

(3) It is necessary for you to pay attention to condensation when the ambient temperature drops suddenly. Condensate water would damage the polarizer and electrical contacted parts of the module. Besides, smear or spot will remain after condensate water evaporating.

(4) If the absolute maximum rating value was exceeded, it may damage the module.

(5) Do not adjust the variable resistor located on the module.

(6) Sufficient suppression to the electromagnetic interference shall be done by system manufacturers. Grounding and shielding may be important to minimize the interference.

(7) Image sticking may occur when the module displayed the same pattern for long time.

(8) Do not connect or disconnect the module in the “power on” condition. Power supply should always be turned on/off by the “power on/off sequence”

(9) Ultra-violet ray filter is necessary for outdoor operation.

9.3 Mounting Precaution

(1) All the operators should be electrically grounded and with Ion-blown equipment turning on when mounting or handling. Dressing finger-stalls out of the gloves is important for keeping the panel clean during the incoming inspection and the process of assembly.

(2) It is unacceptable that the material of cover case contains acetic or chloric. Besides, any other material that could generate corrosive gas or cause circuit break by electro-chemical reaction is not desirable.

(3) The case on which a module is mounted should have sufficient strength so that external force is not transmitted to the module directly.

(4) It is obvious that you should adopt radiation structure to satisfy the temperature specification.

(5) It should be attached to the system tightly by using all holes for mounting, when the module is assembled. Be careful not to apply uneven force to the module, especially to the PCB on the back.

Document Title	M121GNS3 R0 Customer Approved Specification			Page No.	25/25
Document No.	A- M121GNS3-R0-468-02	Issue date	2018/08/22	Revision	00

- (6) A transparent protective film needs to be attached to the surface of the module.
- (7) Do not press or scratch the polarizer exposed with anything harder than HB pencil lead. In addition, don't touch the pin exposed with bare hands directly.
- (8) Clean the polarizer gently with absorbent cotton or soft cloth when it is dirty.
- (9) Wipe off saliva or water droplet as soon as possible. Otherwise, it may cause deformation and fading of color.
- (10) Desirable cleaners are IPA (Isopropyl Alcohol) or hexane. Do not use Ketone type materials (ex. Acetone), Ethyl alcohol, Toluene, Ethyl acid or Methyl chloride. It might permanent damage to the polarizer due to chemical reaction.
- (11) Do not disassemble or modify the module. It may damage sensitive parts in the LCD module, and cause scratches or dust remains. IVO does not warrant the module, if you disassemble or modify the module.

9.4 Handling Precaution

- (1) Static electricity will generate between the film and polarizer, when the protection film is peeled off. It should be peeled off slowly and carefully by operators who are electrically grounded and with Ion-blown equipment turning on. Besides, it is recommended to peel off the film from the bonding area.
- (2) The protection film is attached to the polarizer with a small amount of glue. When the module with protection film attached is stored for a long time, a little glue may remain after peeling.
- (3) If the liquid crystal material leaks from the panel, keep it away from the eyes and mouth. In case of contact with hands, legs or clothes, it must be clean with soap thoroughly.

9.5 Storage Precaution

When storing modules as spares for long time, the following precautions must be executed.

- (1) Store them in a dark place. Do not expose to sunlight or fluorescent light. Keep the temperature between 5°C and 35°C at normal humidity.
- (2) The polarizer surface should not come in contact with any other object. It is recommended that they be stored in the container in which they were shipped.
- (3) It is recommended to use it in a short-time period, after it's unpacked. Otherwise, we would not guarantee the quality.

9.6 Others

When disposing LCD module, obey the local environmental regulations.