



Document name	M116NWR4 R1 Product Specification			Page 2 of 27	
Document No.		Made/Revised date	2015/06/24	Ver.	00

CONTENTS

1.0 GENERAL DESCRIPTIONS 3

2.0 ABSOLUTE MAXIMUM RATINGS 5

3.0 OPTICAL CHARACTERISTICS 5

4.0 ELECTRICAL CHARACTERISTICS 9

5.0 MECHANICAL CHARACTERISTICS 15

6.0 RELIABILITY CONDITIONS 17

7.0 PACKAGE SPECIFICATION 18

8.0 LOT MARK 19

9.0 GENERAL PRECAUTION 20

10.0 EDID FORMAT 21



Document name	M116NWR4 R1 Product Specification			Page 3 of 27	
Document No.		Made/Revised date	2015/06/24	Ver.	00

1.0 General Descriptions

1.1 Introduction

The M116NWR4 R1 is a color active matrix thin film transistor (TFT) liquid crystal display (LCD) that uses amorphous silicon TFT as a switching device. This model is composed of a TFT LCD panel, a driver circuit and a backlight system. This TFT LCD has a 11.6 inch diagonally measured active display area with HD resolution (1,366 horizontal by 768 vertical pixels array).

1.2 Features

- Supported HD Resolution
- eDP1.2 Interface
- Wide View Angle
- Compatible with RoHS Standard

1.3 Product Summary

Items		Specifications	Unit
Screen Diagonal		11.6	inch
Active Area (H x V)		256.13 x 144.00	mm
Number of Pixels (H x V)		1,366 x 768	-
Pixel Pitch (H x V)		0.1875 x 0.1875	mm
Pixel Arrangement		R.G.B. Vertical Stripe	-
Display Mode		Normally Black	-
White Luminance		260 (Typ.)	cd /m ²
Contrast Ratio		800 (Typ.)	-
Response Time		25 (Typ.)	ms
Input Voltage		3.3 (Typ.)	V
Power Consumption		3.0(Max.)	W
Weight		210 (Max.)	g
Outline Dimension (H x V x D)	with PCBA	268.00 (Typ.) x 157.35(Typ.) x 4.80 (Max.)	mm
	without PCBA	268.00 (Typ.) x 157.35(Typ.) x 2.80 (Max.)	mm
Electrical Interface (Logic)		eDP1.2	-
Support Color		262K	-
NTSC		50(Typ.)	%
Viewing Direction		All	-
Surface Treatment		Glare/Hard coating 3H	-

Document name	M116NWR4 R1 Product Specification			Page 4 of 27	
Document No.		Made/Revised date	2015/06/24	Ver.	00

1.4 Functional Block Diagram

Figure 1 shows the functional block diagram of the LCD module.

Figure 1 Block Diagram

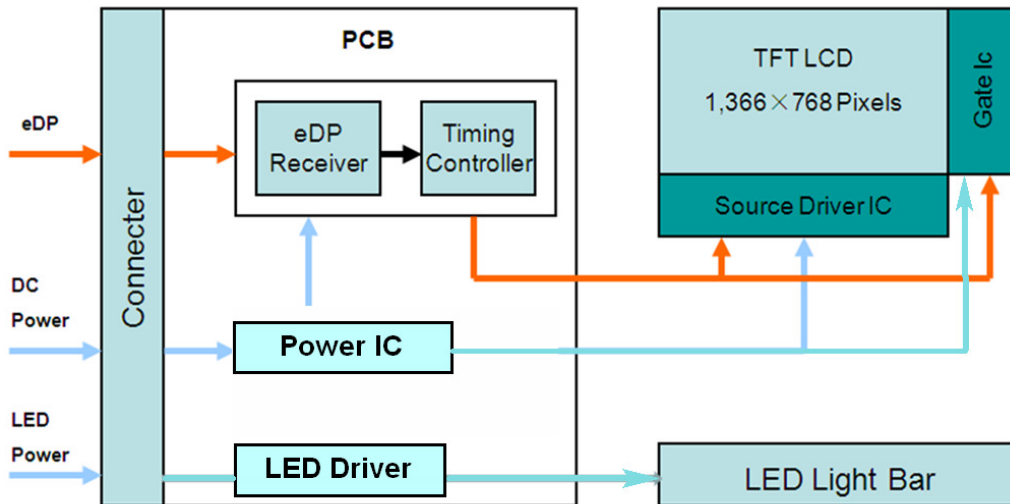

1.5 Pixel Mapping

Figure2 Pixel Mapping

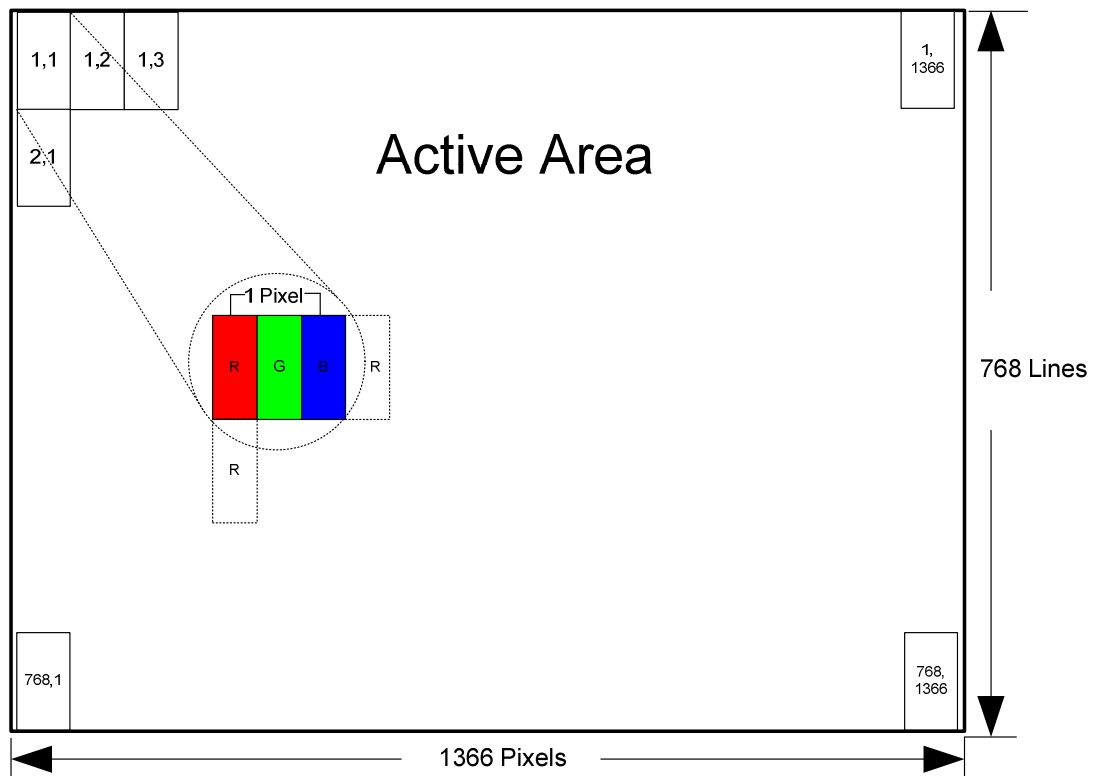



Document name	M116NWR4 R1 Product Specification			Page 5 of 27	
Document No.		Made/Revised date	2015/06/24	Ver.	00

2.0 Absolute Maximum Ratings

Table 1 Electrical & Environment Absolute Rating

Item	Symbol	Min.	Max.	Unit	Note
Logic Supply Voltage	V_{DD}	-0.3	4.0	V	(1),(2)
Logic Input Signal Voltage	V_{Signal}	-0.3	2.4	V	
Operating Temperature	T_{OP}	0	60	°C	(3),(4),(5),(6)
Storage Temperature	T_{ST}	-20	60	°C	
Vibration(Non-operating)	VB	-	1.5	G	(7)
Shock(Non-operating)	Shock	-	240	G	(8)

Note (1) Permanent damage may occur to the LCD module if beyond this specification. Functional operation should be restricted to the conditions described under normal operating conditions.

Note (2) Operating temperature 25°C, humidity 55%RH.

Note (3) ($T \leq 40^\circ\text{C}$) Note static electricity. Maximum wet bulb temperature at 39°C or less. ($T > 40^\circ\text{C}$) No condensation.

Note (4) There is a possibility of causing deterioration in the irregularity and others of the screen and the display fineness though the liquid crystal module doesn't arrive at destruction when using it at $-20 \sim 0^\circ\text{C}$.

Note (5) There is a possibility of causing the fineness deterioration by the prolonged use in the (high temperature) humidity environment (60%RH or more).

Note (6) In the operating temperature item, the low temperature side is the ambient temperature regulations. The high temperature side is the panel surface temperature regulations.

Note (7) 10-500Hz, random vibration, 1hrs for each X, Y, Z axis.

Note (8) 2ms, half sine wave, 1time for $\pm x, \pm y, \pm z$ 6 directions.

3.0 Optical Characteristics



Document name	M116NWR4 R1 Product Specification			Page 6 of 27	
Document No.		Made/Revised date	2015/06/24	Ver.	00

The optical characteristics are measured under stable conditions as following notes.

Table 2 Optical Characteristics

Item	Conditions	Min.	Typ.	Max.	Unit	Note
Viewing Angle (CR>10)	Horizontal	θ_{x+}	85	89	-	degree (1),(2),(3)
		θ_{x-}	85	89	-	
	Vertical	θ_{y+}	85	89	-	
		θ_{y-}	85	89	-	
Contrast Ratio	Center	560	800	-	-	(1),(2),(4)
Response Time	Rising + Falling	-	25	30	ms	(1),(2),(5)
Color Chromaticity (CIE1931)	Red x	Typ. -0.03	0.5877	Typ. +0.03	-	(1),(2),(3) $\theta_x=\theta_y=0^\circ$
	Red y		0.3298		-	
	Green x		0.3020		-	
	Green y		0.5567		-	
	Blue x		0.1760		-	
	Blue y		0.1030		-	
	White x	0.283	0.313	0.343	-	
White y	0.299	0.329	0.359	-		
NTSC	-	47	50	-	%	(1),(2),(3) $\theta_x=\theta_y=0^\circ$
White Luminance	5 Points Average	187	220	-	cd/m ²	(1),(2),(6)
Luminance Uniformity	5Points	80	-	-	%	(1),(2),(7)
	13Points	67	-	-		

Note (1) Measurement Setup:

The LCD module should be stabilized at given temperature(25°C) for 15 minutes to Avoid abrupt temperature change during measuring. In order to stabilize the luminance, the measurement should be executed after lighting backlight for 15 minutes in a windless room.

Document name	M116NWR4 R1 Product Specification			Page 7 of 27	
Document No.		Made/Revised date	2015/06/24	Ver.	00

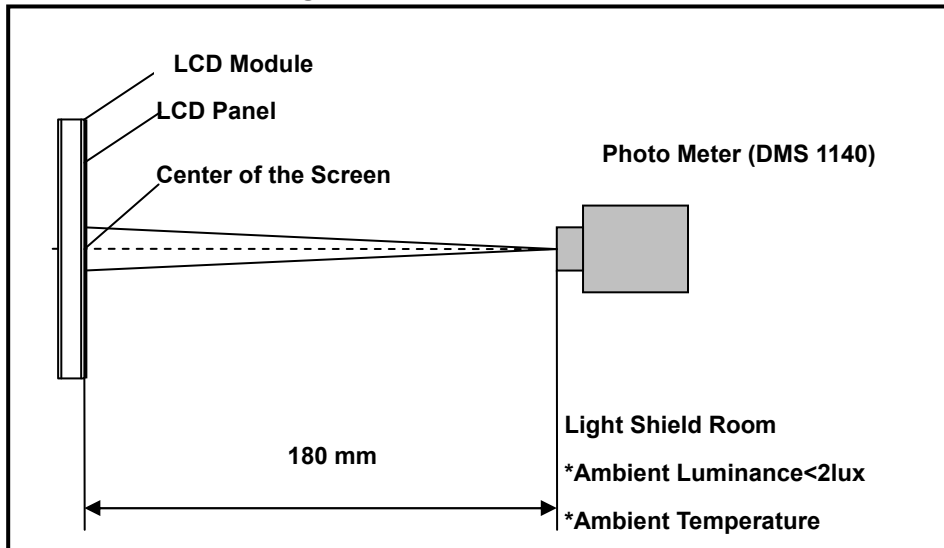
Figure 3 Measurement Setup

Note (2) The LED input parameter setting as:

V_LED: 12V

PWM_LED: Duty 100%

Note (3) Definition of Viewing Angle

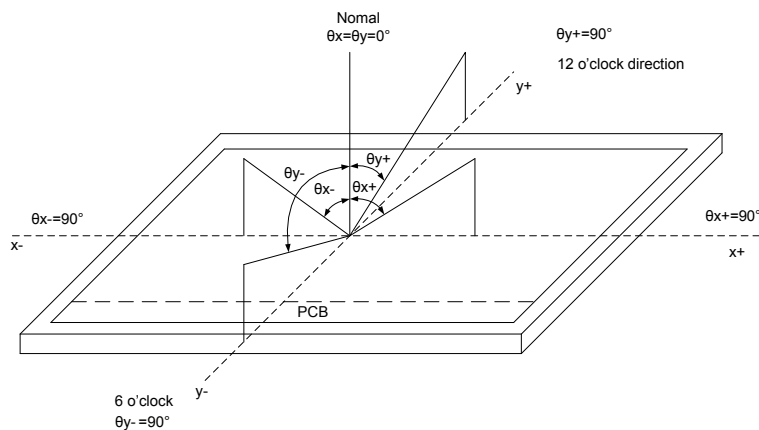
Figure 4 Definition of Viewing Angle

Note (4) Definition Of Contrast Ratio (CR)

The contrast ratio can be calculated by the following expression

$$\text{Contrast Ratio (CR)} = L_{63} / L_0$$

L63: Luminance of gray level 63, L0: Luminance of gray level 0

Document name	M116NWR4 R1 Product Specification			Page 8 of 27	
Document No.		Made/Revised date	2015/06/24	Ver.	00

Note (5) Definition Of Response Time (T_R , T_F)

Figure 5 Definition of Response Time

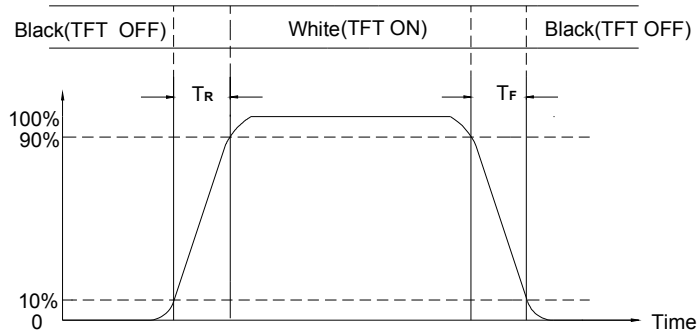

Note (6) Definition Of Luminance White

Measure the luminance of gray level 63 at center point (Ref.: Active Area)

Display Luminance= $(L_1+L_2+L_3+L_4+L_5) / 5$

H—Active Area Width, V—Active Area Height, L—Luminance

Figure 6 Measurement Locations Of 5 Points

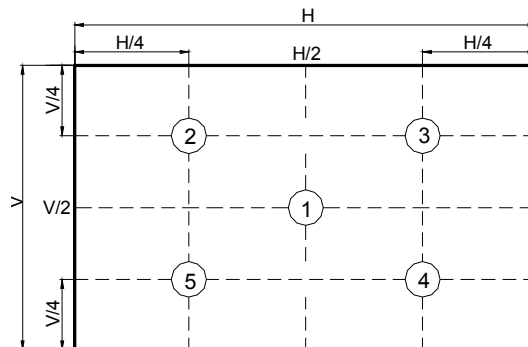

Note (7) Definition Of Luminance Uniformity (Ref: Active Area)

Measure the luminance of gray level 63 at 5 points and 13 points.

Luminance Uniformity= $\text{Min.}(L_1, L_2, \dots L_5) / \text{Max.}(L_1, L_2, \dots L_5)$

Luminance Uniformity= $\text{Min.}(L_1, L_2, \dots L_{13}) / \text{Max.}(L_1, L_2, \dots L_{13})$

H—Active Area Width, V—Active Area Height, L—Luminance

Document name	M116NWR4 R1 Product Specification			Page 9 of 27	
Document No.		Made/Revised date	2015/06/24	Ver.	00

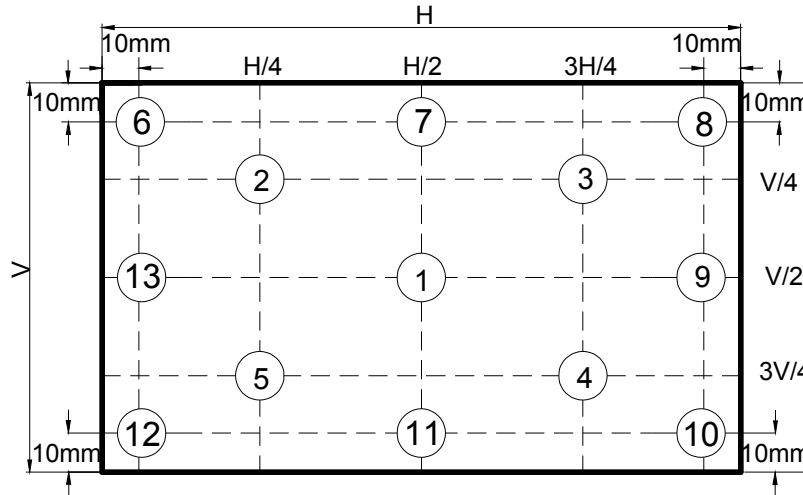
Figure 7 Measurement Locations Of 13 Points

4.0 Electrical Characteristics

4.1 Interface Connector

Table 3 Signal Connector Type

Item	Description
Manufacturer / Type	STM/MSAK24025P30D or Compatible
Mating Receptacle / Type (Reference)	I-PEX 20455-030T-11 or Compatible

Table 4 Signal Connector Pin Assignment

Pin No.	Symbol	Description	Remarks
1	NC	NC	-
2	H_GND	High Speed Ground	-
3	NC	NC	-
4	NC	NC	-
5	H_GND	High Speed Ground	-
6	Lane0_N	Complement Signal Link Lane 0	-
7	Lane0_P	True Signal Link Lane 0	-
8	H_GND	High Speed Ground	-
9	AUX_P	True Signal Auxiliary Channel	-
10	AUX_N	Complement Signal Auxiliary Channel	-
11	H_GND	High Speed Ground	-
12	LCD_VCC	LCD logic and driver power(3.3 +/-0.3V)	-
13	LCD_VCC	LCD logic and driver power(3.3 +/-0.3V)	-



InfoVision Optoelectronics (Kunshan) Co.,LTD.

Document name	M116NWR4 R1 Product Specification			Page 10 of 27	
Document No.		Made/Revised date	2015/06/24	Ver.	00

14	BIST	LCD Panel Self-Test Enable (optional)	-
15	LCD_GND	LCD logic and driver ground	-
16	LCD_GND	LCD logic and driver ground	-
17	HPD	HPD signal pin	-
18	BL_GND	Backlight ground	-
19	BL_GND	Backlight ground	-
20	BL_GND	Backlight ground	-
21	BL_GND	Backlight ground	-
22	Backlight_ENABLE	Backlight On/Off	-
23	BL_PWM_DIM	System PWM signal input for dimming	-
24	NC	NC	-
25	NC	NC	-
26	BL PWR	Backlight power(5~21V)	-
27	BL PWR	Backlight power(5~21V)	-
28	BL PWR	Backlight power(5~21V)	-
29	BL PWR	Backlight power(5~21V)	-
30	NC	NC	-

Document name	M116NWR4 R1 Product Specification			Page 11 of 27	
Document No.		Made/Revised date	2015/06/24	Ver.	00

4.2 Signal Electrical Characteristics

Table 5 Display Port Main Link

Parameter	Description	Min.	Typ.	Max.	Unit
V_{CM}	Differentia Common Mode Voltage	0	-	2.0	V
$V_{DIFF P-P}$ Level 1	Differential Peak to Peak Voltage Level 1	0.34	0.40	0.46	V
$V_{DIFF P-P}$ Level 2	Differential Peak to Peak Voltage Level 2	0.51	0.60	0.68	V
$V_{DIFF P-P}$ Level 3	Differential Peak to Peak Voltage Level 3	0.69	0.80	0.92	V
$V_{DIFF P-P}$ Level 4	Differential Peak to Peak Voltage Level 4	1.02	1.20	1.38	V

Note: (1) Input signals shall be low or Hi- resistance state when VDD is off.

(2) It is recommended to refer the specifications of VESA Display Port Standard V1.2 in detail.

(3) Follow as VESA display port standard V1.2 at both 1.62 and 2.7 Gbps link rates.

Figure 8 Display Port Main Link Signal

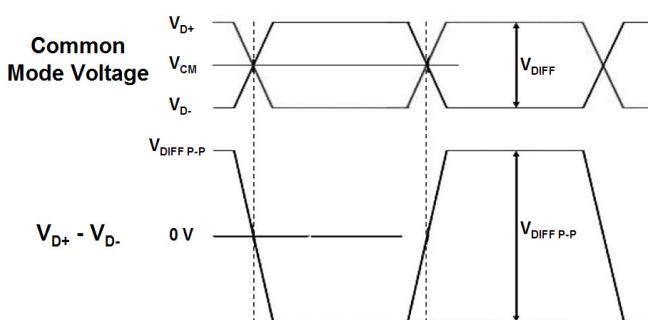

Figure 9 Display Port AUX_CH Signal

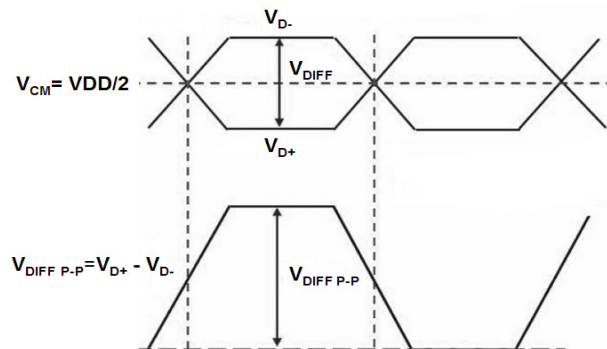

Table 6 Display Port AUX_CH

Parameter	Description	Min.	Typ.	Max.	Unit
V_{CM}	Differentia Common Mode Voltage	0	VDD/2	2	V
$V_{DIFF P-P}$	Differential Peak to Peak Voltage	0.39	-	1.38	V

Note: Follow as VESA display port standard V1.2.

Table 7 Display Port V_{HPD}

Parameter	Description	Min.	Typ.	Max.	Unit
V_{HPD}	HPD Voltage	2.25	-	3.60	V

Note: Follow as VESA display port standard V1.2.



Document name	M116NWR4 R1 Product Specification			Page 12 of 27	
Document No.		Made/Revised date	2015/06/24	Ver.	00

4.3 Interface Timings

Table 8 Interface Timings

Parameter	Symbol	Min.	Typ.	Max.	Unit
Clock Frequency	Fclk	67.5	72.33	76.3	MHz
H Total Time	HT	1,502	1,526	1,586	Clocks
H Active Time	HA	1,366	1,366	1,366	Clocks
V Total Time	VT	782	790	802	Lines
V Active Time	VA	768	768	768	Lines
Frame Rate	FV	55	60	65	Hz

4.4 Input Power Specifications

Input power specifications are as follows.

Table 9 Input Power Specifications

Parameter	Symbol	Min.	Typ.	Max.	Unit	Note	
System Power Supply							
LCD Drive Voltage (Logic)	V _{DD}	3.0	3.3	3.6	V	(2), (4)	
VDD Current	White Pattern	I _{DD}	-	-	0.18	A	(3),(4)
VDD Power Consumption	White Pattern	P _{DD}	-	-	0.6	W	
Rush Current	I _{Rush}	-	-	1.5	A	(1),(4),(5)	
Allowable Logic/LCD Drive Ripple Voltage	V _{VDD-RP}	-	-	200	mV	(4)	
LED Power Supply							
LED Input Voltage	V _{LED}	5	12	21	V	(4)	
LED Power Consumption	P _{LED}	-	-	2.4	W		
LED Forward Voltage	V _F	2.8	-	3.1	V		
LED Forward Current	I _F	-	20	-	mA		
PWM Signal Voltage	High	V _{PWM}	2.2	-	-		V
	Low		-	-	0.4		V
LED Enable Voltage	High	V _{LED_EN}	2.2	-	-		V
	Low		-	-	0.4		V
Input PWM Frequency	F _{PWM}	200	-	1,000	Hz		
Duty Ratio	PWM	1	-	100	%		(4),(6)
LED Life Time	LT	15,000	-	-	Hours	(4),(6)	

Document name	M116NWR4 R1 Product Specification			Page 13 of 27	
Document No.		Made/Revised date	2015/06/24	Ver.	00

Note (1) Measure Condition

Figure 10 VDD Rising Time

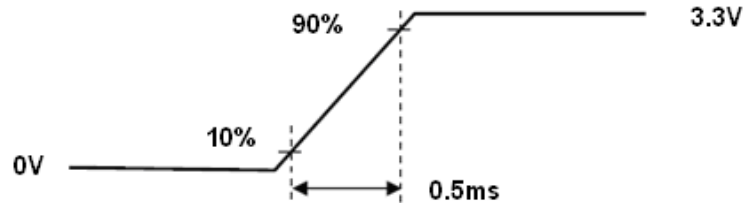

Note (2) VDD Power Dip Condition

$V_{TH} < V_{DD} \leq V_{min}$, $t_d \leq 10ms$ (a time of the voltage return to normal), our panel can revive automatically.

Figure 11 VDD Power Dip

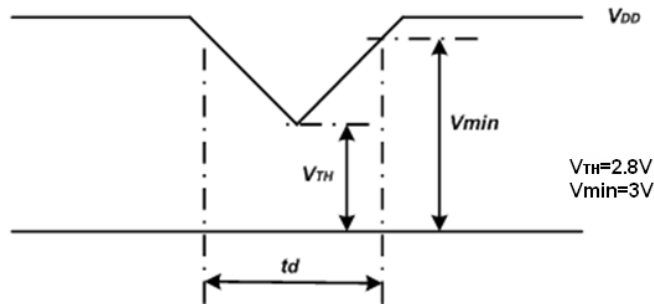

Note (3) Frame Rate=60Hz, VDD=3.3V, DC Current.

Note (4) Operating temperature 25°C, humidity 55%RH.

Note (5) The reference measurement circuit of I_rush current.

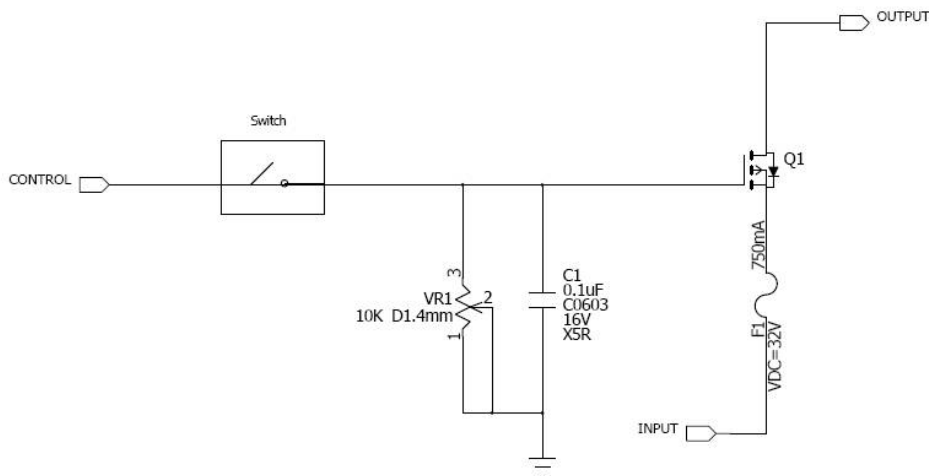

Note (6) The LED life time define as the estimated time to 50% degradation of initial luminous.

Document name	M116NWR4 R1 Product Specification			Page 14 of 27	
Document No.		Made/Revised date	2015/06/24	Ver.	00

4.5 Power ON/OFF Sequence

Interface signals are also shown in the chart. Signals from any system shall be Hi- resistance state or low level when VCC voltage is off.

Figure 12 Power Sequence

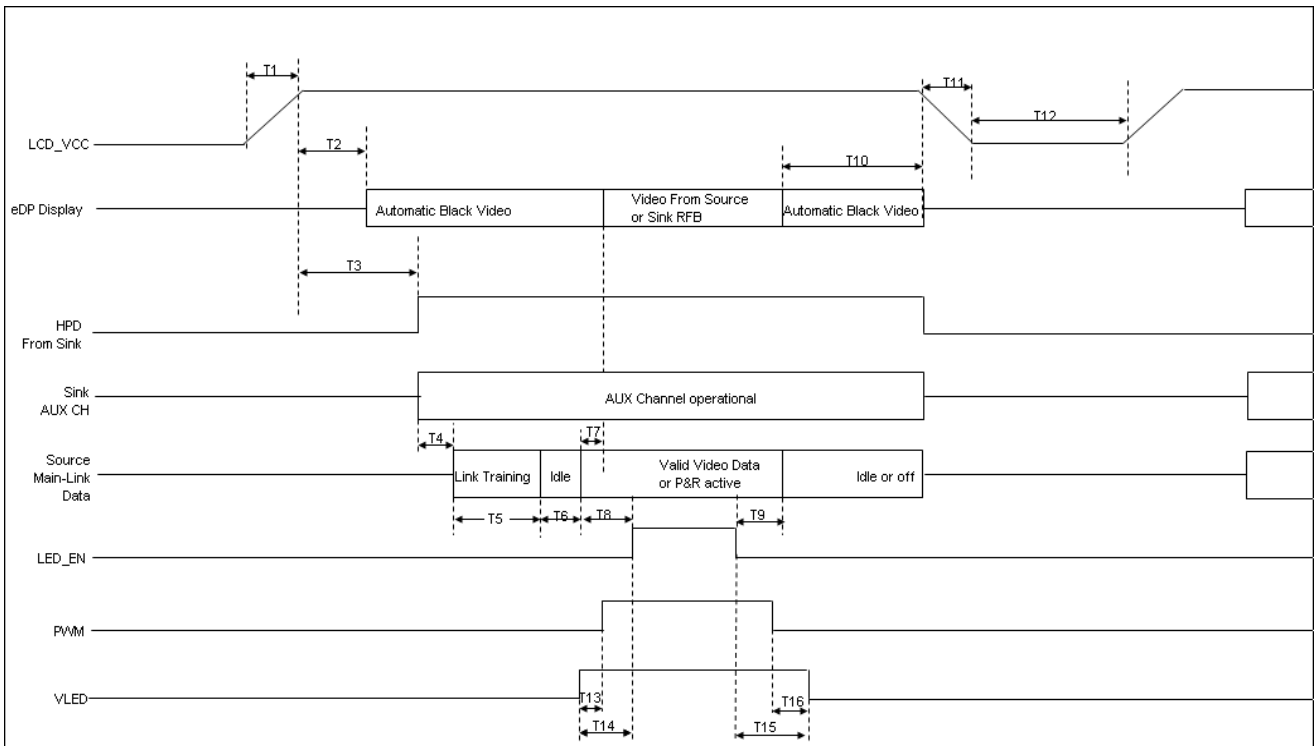

Table 10 Power Sequencing Requirements

Parameter	Symbol	Min.	Typ.	Max.	Unit
LCD_VCC Rise Time (10% to 90%)	T1	0.5	-	10	ms
Delay from LCD_VCC to automatic Black Video generation	T2	0	-	200	ms
Delay from LCD_VCC to HPD high	T3	0	-	200	ms
Delay from HPD high to link training initialization	T4	-	-	-	ms
Link training duration	T5	-	-	-	ms
Link idle	T6	-	-	-	ms
Delay from valid video data from Source to video on display	T7	0	-	50	ms
Delay from valid video data from Source to backlight enable	T8	-	-	-	ms
Delay from backlight disable to end of valid video data	T9	-	-	-	ms
Delay from end of valid video data from Source to VCC off	T10	0	-	500	ms
LCD_VCC fall time (90% to 10%)	T11	0	-	10	ms
VCC off time	T12	500	-	-	ms



Document name	M116NWR4 R1 Product Specification			Page 15 of 27	
Document No.		Made/Revised date	2015/06/24	Ver.	00

Delay from VLED to PWM	T13	0	-	-	ms
Delay from VLED to backlight enable	T14	0	-	-	ms
Delay from backlight disable to VLED off	T15	0	-	-	ms
Delay from PWM off to VLED off	T16	0	-	-	ms

5.0 Mechanical Characteristics

5.1 Outline Drawing

Figure 13 Reference Outline Drawing (Front Side)

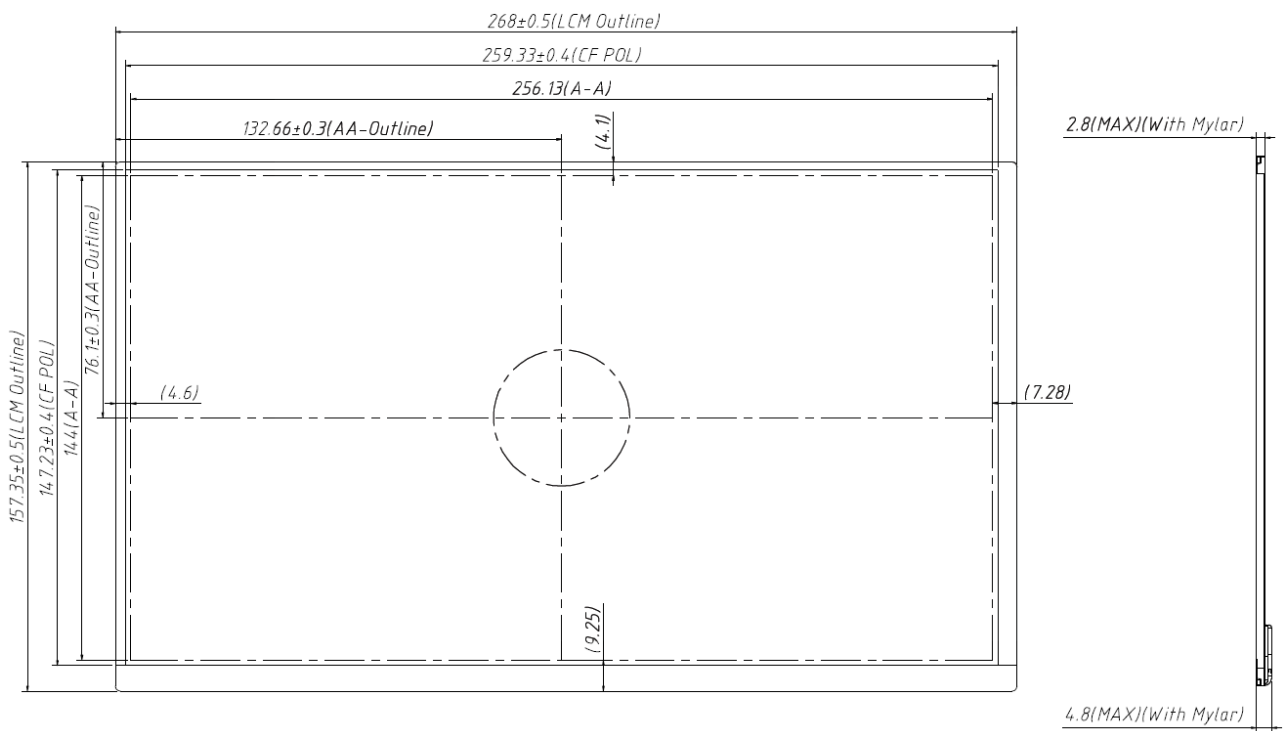

Unit: mm



Document name	M116NWR4 R1 Product Specification			Page 16 of 27	
Document No.		Made/Revised date	2015/06/24	Ver.	00

Figure 14 Reference Outline Drawing (Back Side)

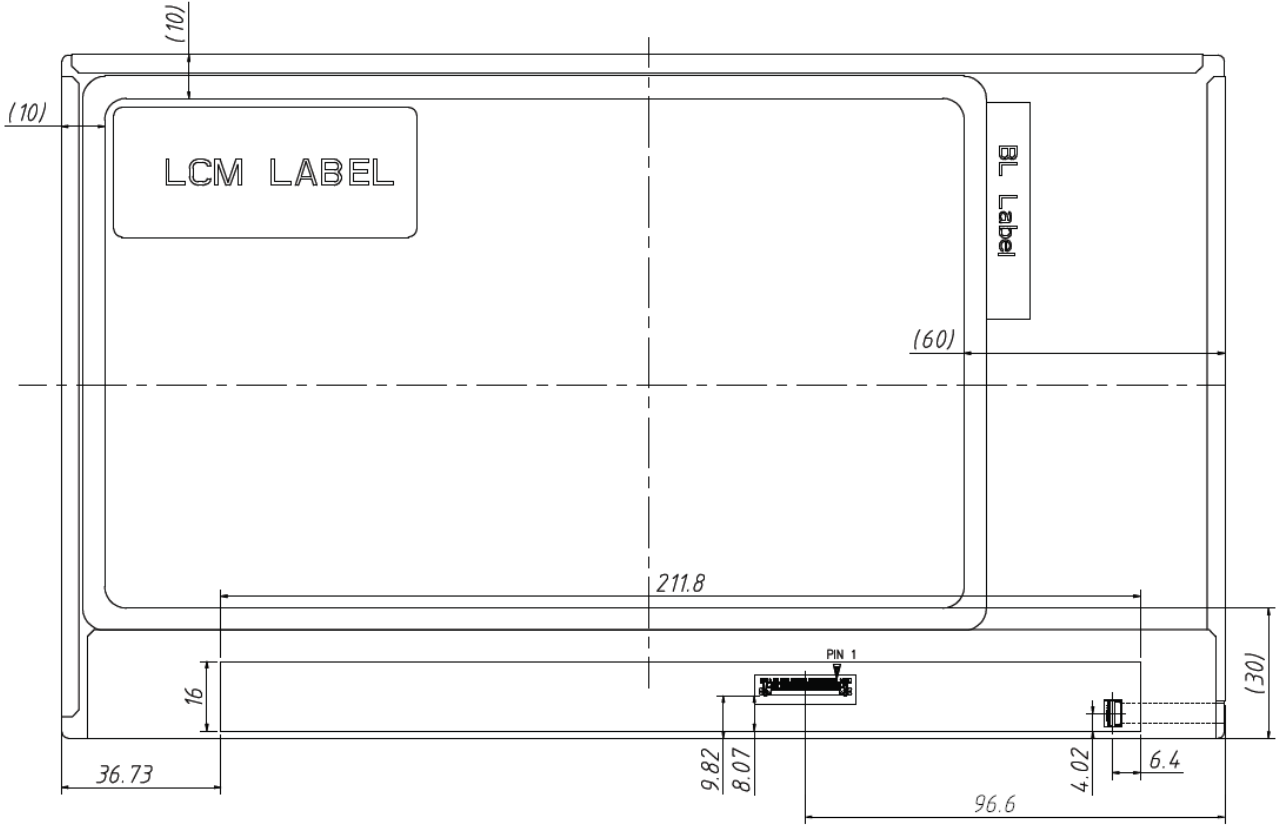

Unit: mm



Document name	M116NWR4 R1 Product Specification			Page 17 of 27	
Document No.		Made/Revised date	2015/06/24	Ver.	00

5.2 Dimension Specifications**Table 11 Module Dimension Specifications**

Item		Min.	Typ.	Max.	Unit
Width		267.5	268.0	268.5	mm
Height		156.85	157.35	157.85	mm
Thickness	Without PCBA	-	-	2.8	mm
	With PCBA	-	-	4.8	mm
Weight		-	-	210	g

6.0 Reliability Conditions

Item		Package	Test Conditions		Note
Low Temperature Operating Test		Module	0°C, 300 hours		(1),(2),(3),(4)
Low Temperature Storage Test		Module	-20°C, 300 hours		(1),(2),(4)
High Temperature/High Humidity Operating Test		Module	60°C, 90%RH,300 hours		(1),(2),(3),(4)
Shock Non-operating Test		Module	240G, 2ms, 1time for ±x,±y,±z 6 directions		(4)
Vibration Non-operating Test		Module	1.5G,10-500Hz,X Y Z each axis/1h		
ESD Test	Operating	Module	Contact	± 8 KV, 150pF(330Ohm)	(5)
			Air	± 15 KV, 150pF(330Ohm)	

Note (1) All the judgments are under room temperature and the sample need to be static more than 2 hours in the room temperature before judge.

Note (2) During measurement, the condensation water or remains shall not be allowed.

Note (3) In operating test, the backlight voltage and current must be in specfication.

Note (4) There is no display function issue occurred, all the cosmetic specification is judged before the reliability stress.

Note (5) In case of malfunction defect caused by ESD damage. If it would be recovered to normal state after resetting, it would be judge as pass.



Document name	M116NWR4 R1 Product Specification			Page 18 of 27	
Document No.		Made/Revised date	2015/06/24	Ver.	00

7.0 Package Specification

Figure 15 Packing Method

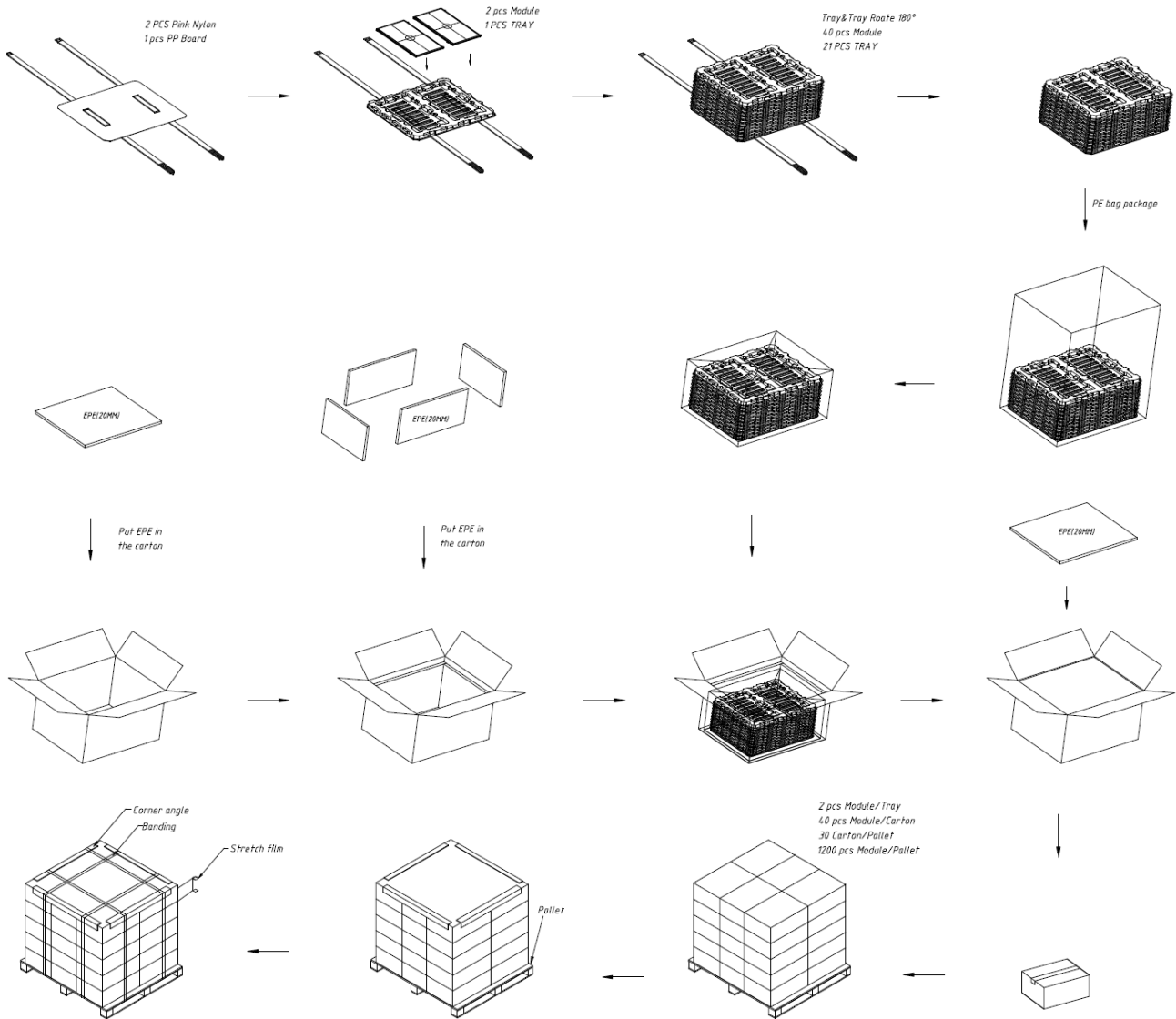

Document name	M116NWR4 R1 Product Specification			Page 19 of 27	
Document No.		Made/Revised date	2015/06/24	Ver.	00

8.0 Lot Mark

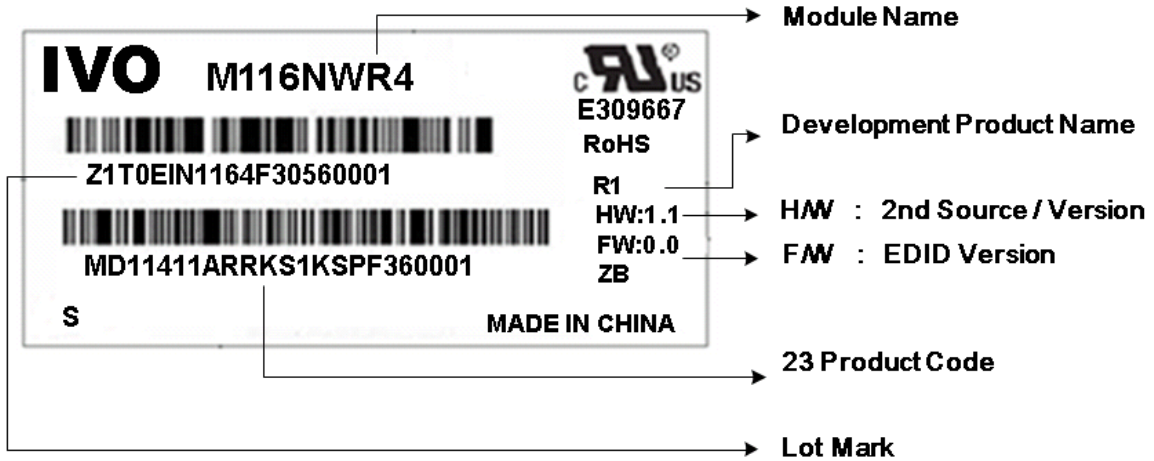

Note: This picture is only an example.

8.1 20 Lot Mark

1	2	3	4	5	6	7	8	9	10	11	12	13	14	15	16	17	18	19	20
---	---	---	---	---	---	---	---	---	----	----	----	----	----	----	----	----	----	----	----

Code 1,2,4,5,6,7,8,9,10,11,16: IVO internal flow control code.
 Code 3: Production Location.
 Code 12: Production Year.
 Code 13: Production Month.
 Code 14,15: Production Day.
 Code 17,18,19,20: Serial Number.

8.2 23 Product Barcode

1	2	3	4	5	6	7	8	9	10	11	12	13	14	15	16	17	18	19	20	21	22	23
---	---	---	---	---	---	---	---	---	----	----	----	----	----	----	----	----	----	----	----	----	----	----

Code 1,2: Manufacture District.
 Code 3,4,5,6,7: IVO internal module name.
 Code 8,9,10,13,16: IVO internal flow control code.
 Code 11,12: Cell location Suzhou, China defined as "KS".
 Code 14,15: Module location Kunshan, China defined as "KS"; Yangzhou, China defined as "YZ"; Shenzhen, China defined as "SE"; Zhuhai, China defined as "ZH"; Suzhou, China defined as "SZ".
 Code 17,18,19 : Year, Month, Day refer to Note(1), Note(2) and Note(3).

Note (1) Production Year

Year	2006	2007	2008	2009	2010	2011	2012	2013	2035
Mark	6	7	8	9	A	B	C	D	Z

Note (2) Production Month

Month	Jan.	Feb.	Mar.	Apr.	May.	Jun.	Jul.	Aug.	Sep.	Oct	Nov.	Dec.
Mark	1	2	3	4	5	6	7	8	9	A	B	C



Document name	M116NWR4 R1 Product Specification			Page 20 of 27	
Document No.		Made/Revised date	2015/06/24	Ver.	00

Note (3) Production Day: 1~V.
Code 20~23 : Serial Number.

9.0 General Precaution

9.1 Use Restriction

This product is not authorized for use in life supporting systems, aircraft navigation control systems, military systems and any other application where performance failure could be life-threatening or otherwise catastrophic.

9.2 Handling Precaution

- (1) Please mount LCD module by using mounting holes arranged in four corners tightly.
- (2) Do not disassemble or modify the module. It may damage sensitive parts inside LCD module, and may cause scratches or dust on the display. IVO does not warrant the module, if customers disassemble or modify the module.
- (3) If LCD panel is broken and liquid crystal spills out, do not ingest or inhale liquid crystal, and do not contact liquid crystal with skin. If liquid crystal contacts mouth or eyes, rinse out with water immediately. If liquid crystal contacts skin or cloths, wash it off immediately with alcohol and rinse thoroughly with water.
- (4) Disconnect power supply before handling LCD module.
- (5) Refrain from strong mechanical shock and /or any force to the module.
- (6) Do not exceed the absolute maximum rating values, such as the supply voltage variation, input voltage variation, variation in parts parameters, environmental temperature; etc otherwise LCD module may be damaged. It's recommended employing protection circuit for power supply.
- (7) Do not touch, push or rub the polarizer with anything harder than HB pencil lead. Use fingerstalls of soft gloves in order to keep clean display quality, when persons handle the LCD module for incoming inspection or assembly.
- (8) When the surface is dusty, please wipe gently with absorbent cotton or other soft material. When cleaning the adhesives, please use absorbent cotton wetted with a little petroleum benzene or other adequate solvent.
- (9) Wipe off saliva or water drops as soon as possible. If saliva or water drops contact with polarizer for a long time, they may causes deformation or color fading.
- (10) Protection film must remove very slowly from the surface of LCD module to prevent from electrostatic occurrence.
- (11) Because LCD module uses CMOS-IC on circuit board and TFT-LCD panel, it is very weak to electrostatic discharge, please be careful with electrostatic discharge. Persons who handle the module should be grounded through adequate methods.
- (12) Do not adjust the variable resistor located on the module.

9.3 Storage Precaution

- (1) Please do not leave LCD module in the environment of high humidity and high temperature for a long time.
- (2) The module shall not be exposed under strong light such as direct sunlight. Otherwise, display characteristics may be changed.
- (3) The module should be stored in a dark place. It is prohibited to apply sunlight or fluorescent light in storage.

9.4 Operation Precaution

- (1) Do not connect or disconnect the module in the "Power On" condition.



Document name	M116NWR4 R1 Product Specification			Page 21 of 27	
Document No.		Made/Revised date	2015/06/24	Ver.	00

- (2) Power supply should always be turned on/off by "Power On/Off Sequence".
- (3) Module has high frequency circuits. Sufficient suppression to the electromagnetic interference should be done by system manufacturers. Grounding and shielding methods may be important to minimize the interference.
- (4) After installation of the TFT module into an enclosure, do not twist nor bend the TFT module even momentary. At designing the enclosure, it should be taken into consideration that no bending/twisting forces are applied to the TFT module from outside. Otherwise the TFT module may be damaged.

9.5 Others

- (1) Ultra-violet ray filter is necessary for outdoor operation.
- (2) Avoid condensation of water which may result in improper operation or disconnection of electrode.
- (3) If the module keeps displaying the same pattern for a long period of time, the image may be "sticked" to the screen.
- (4) This module has its circuitry PCB's on the rear side and should be handled carefully in order not to be stressed.

9.6 Disposal

When disposing LCD module, obey the local environmental regulations.

10.0 EDID format

Address (DEC)	Address (HEX)	Field Name & Comments	Value (HEX)	Value (BIN)	Value (DEC)
0	0	Header	0	0	0
1	1	Header	FF	11111111	255
2	2	Header	FF	11111111	255
3	3	Header	FF	11111111	255
4	4	Header	FF	11111111	255
5	5	Header	FF	11111111	255
6	6	Header	FF	11111111	255
7	7	Header	0	0	0
8	8	manufacture code	26	100110	38
9	9	manufacture code	CF	11001111	207



InfoVision Optoelectronics (Kunshan) Co.,LTD.

Document name	M116NWR4 R1 Product Specification			Page 22 of 27	
Document No.		Made/Revised date	2015/06/24	Ver.	00

10	A	Product Code	8C	10001100	140
11	B	Product Code	4	100	4
12	C	LCD module Serial No –("0" if not used)	0	0	0
13	D	LCD module Serial No –("0" if not used)	0	0	0
14	E	LCD module Serial No –("0" if not used)	0	0	0
15	F	LCD module Serial No –("0" if not used)	0	0	0
16	10	Week of manufacture	0A	1010	10
17	11	Year of manufacture	19	11001	25
18	12	EDID Structure Ver # = 1	1	1	1
19	13	EDID revision # = 3	4	100	4
20	14	Video I/P definition = Digital I/P (80h)	95	10010101	149
21	15	Max H image size = (Rounded to cm)	1A	11010	26
22	16	Max V image size = (Rounded to cm)	0E	1110	14
23	17	Display Gamma	78	1111000	120
24	18	Feature support (no DPMS, Active off, RGB, timing BLK 1)	0A	1010	10
25	19	Red/Green Low bits (RxRy/GxGy)	96	10010110	150
26	1A	Blue/White Low bits (BxBY/WxWy)	10	10000	16
27	1B	Red X Rx	96	10010110	150
28	1C	Red Y Ry	54	1010100	84
29	1D	Green X Gx	4D	1001101	77



InfoVision Optoelectronics (Kunshan) Co.,LTD.

Document name	M116NWR4 R1 Product Specification			Page 23 of 27	
Document No.		Made/Revised date	2015/06/24	Ver.	00

30	1E	Green Y Gy	8E	10001110	142
31	1F	Blue X Bx	2D	101101	45
32	20	Blue Y By	1A	11010	26
33	21	White X Wx	50	1010000	80
34	22	White Y Wy	54	1010100	84
35	23	Established timings 1 (00h if not used)	0	0	0
36	24	Established timing 2 (00h if not used)	0	0	0
37	25	Manufacturer@39;s timings (00h if not used)	0	0	0
38	26	Standard timing ID1 (01h if not used)	1	1	1
39	27	Standard timing ID1 (01h if not used)	1	1	1
40	28	Standard timing ID2 (01h if not used)	1	1	1
41	29	Standard timing ID2 (01h if not used)	1	1	1
42	2A	Standard timing ID3 (01h if not used)	1	1	1
43	2B	Standard timing ID3 (01h if not used)	1	1	1
44	2C	Standard timing ID4 (01h if not used)	1	1	1
45	2D	Standard timing ID4 (01h if not used)	1	1	1
46	2E	Standard timing ID5 (01h if not used)	1	1	1
47	2F	Standard timing ID5 (01h if not used)	1	1	1
48	30	Standard timing ID6 (01h if not used)	1	1	1
49	31	Standard timing ID6	1	1	1



Document name	M116NWR4 R1 Product Specification			Page 24 of 27	
Document No.		Made/Revised date	2015/06/24	Ver.	00

		(01h if not used)			
50	32	Standard timing ID7 (01h if not used)	1	1	1
51	33	Standard timing ID7 (01h if not used)	1	1	1
52	34	Standard timing ID8 (01h if not used)	1	1	1
53	35	Standard timing ID8 (01h if not used)	1	1	1
54	36	Pixel Clock LSB	87	10000111	135
55	37	Pixel Clock HSB	1B	11011	27
56	38	Horizontal Active (lower 8 bits)	56	1010110	86
57	39	Hor blanking (lower 8 bits)	88	10001000	136
58	3A	Horizontal Active/Horizontal blanking (upper4:4 bits)	50	1010000	80
59	3B	Vertical active(lower 8 bits)	0	0	0
60	3C	Vertical blanking(lower 8 bits)	0E	1110	14
61	3D	Vertical Active : Vertical Blanking (upper4:4 bits)	30	110000	48
62	3E	Horizontal Sync Offset	28	101000	40
63	3F	Horizontal Sync Pulse Width	20	100000	32
64	40	Vertical Sync Offset , Sync Width	55	1010101	85
65	41	Horizontal Vertical Sync Offset/Width	0	0	0



InfoVision Optoelectronics (Kunshan) Co.,LTD.

Document name	M116NWR4 R1 Product Specification			Page 25 of 27	
Document No.		Made/Revised date	2015/06/24	Ver.	00

		upper 2 bits			
66	42	Horizontal Image Size	0	0	0
67	43	Vertical image Size	90	10010000	144
68	44	Horizontal Image Size / Vertical image size	10	10000	16
69	45	Horizontal Border = (0 for Notebook LCD)	0	0	0
70	46	Vertical Border = (0 for Notebook LCD)	0	0	0
71	47	Non-interlaced, Normal, no stereo, Separate sync, H/V pol Negatives,	19	11001	25
72	48	Timing Descriptor #2	0	0	0
73	49		0	0	0
74	4A		0	0	0
75	4B		0	0	0
76	4C		0	0	0
77	4D		0	0	0
78	4E		0	0	0
79	4F		0	0	0
80	50		0	0	0
81	51		0	0	0
82	52		0	0	0
83	53		0	0	0
84	54		0	0	0
85	55		0	0	0
86	56		0	0	0
87	57		0	0	0



InfoVision Optoelectronics (Kunshan) Co.,LTD.

Document name	M116NWR4 R1 Product Specification			Page 26 of 27	
Document No.		Made/Revised date	2015/06/24	Ver.	00

88	58		0	0	0
89	59		0	0	0
90	5A	Detailed timing/monitor descriptor#3	0	0	0
91	5B	Flag	0	0	0
92	5C	Flag	0	0	0
93	5D	Range limits	FE	11111110	254
94	5E	Flag	0	0	0
95	5F	Min. Vertical Freq	49	1001001	73
96	60	Max. Vertical Freq	6E	1101110	110
97	61	Min. Horizontal Freq	66	1100110	102
98	62	Max.Horizontal Freq	6F	1101111	111
99	63	Max. Pixel Clock Freq	56	1010110	86
100	64		69	1101001	105
101	65		73	1110011	115
102	66		69	1101001	105
103	67		6F	1101111	111
104	68		6E	1101110	110
105	69	New line character indicates end of ASCII string	0A	1010	10
106	6A		20	100000	32
107	6B		20	100000	32
108	6C	Detailed timing/monitor descriptor #4	0	0	0
109	6D		0	0	0
110	6E		0	0	0
111	6F	FE (hex) defines ASCII string	FE	11111110	254



InfoVision Optoelectronics (Kunshan) Co.,LTD.

Document name	M116NWR4 R1 Product Specification			Page 27 of 27	
Document No.		Made/Revised date	2015/06/24	Ver.	00

112	70	Flag	0	0	0
113	71	Manufacture P/N	4D	1001101	77
114	72	Manufacture P/N	31	110001	49
115	73	Manufacture P/N	31	110001	49
116	74	Manufacture P/N	36	110110	54
117	75	Manufacture P/N	4E	1001110	78
118	76	Manufacture P/N	57	1010111	87
119	77	Manufacture P/N	52	1010010	82
120	78	Manufacture P/N	34	110100	52
121	79	Manufacture P/N	20	100000	32
122	7A	Manufacture P/N	52	1010010	82
123	7B	Manufacture P/N	31	110001	49
124	7C	New line character indicates end of ASCII string	20	100000	32
125	7D		0A	1010	10
126	7E	Extension Flag = 00	0	0	0
127	7F	Checksum	29	101001	41