

Document Name	M150GNN2 R0 Customer Approval Specification			Page 1 of 24	
Document No.	A-M150GNN2-R0-468-02	Made/Revised Date	2019/04/24	Ver.	00

Customer Approval Specification

To: 苏州与来视讯科技有限公司

Product Name: M150GNN2 R0

Document Issue Date: 2019/04/24

Customer	InfoVision Optoelectronics
<p><u>SIGNATURE</u></p> <p>_____</p> <p>_____</p> <p>_____</p> <p>Please return 1 copy for your confirmation with your signature and comments.</p>	<p><u>SIGNATURE</u></p> <p>REVIEWED BY CQM</p> <p>_____</p> <p>PREPARED BY FAE</p> <p>_____</p>

- Note: 1. Please contact InfoVision Company, before designing your product based on this product.
 2. The information contained herein is presented merely to indicate the characteristics and performance of our products. No responsibility is assumed by IVO for any intellectual property claims or other problems that may result from application based on the module described herein.

FQ-7-30-0-009-03D

Document Name	M150GNN2 R0 Customer Approval Specification			Page 2 of 24	
Document No.	A-M150GNN2-R0-468-02	Made/Revised Date	2019/04/24	Ver.	00

Revision	Date	Page	Old Description	New Description	Remark
00	2019/04/24	-	First issued.	-	-

IVO Confidential document

Document Name	M150GNN2 R0 Customer Approval Specification			Page 3 of 24	
Document No.	A-M150GNN2-R0-468-02	Made/Revised Date	2019/04/24	Ver.	00

Contents

1.0 General Descriptions4

2.0 Absolute Maximum Ratings.....6

3.0 Optical Characteristics.....7

4.0 Electrical Characteristics.....10

5.0 Mechanical Characteristics18

6.0 Reliability Conditions20

7.0 Package Specification.....21

8.0 Lot Mark22

9.0 General Precaution.....23

IVO Confidential document

Document Name	M150GNN2 R0 Customer Approval Specification			Page 4 of 24	
Document No.	A-M150GNN2-R0-468-02	Made/Revised Date	2019/04/24	Ver.	00

1.0 General Descriptions

1.1 Introduction

The M150GNN2 R0 is a Color Active Matrix Liquid Crystal Display with a back light system. The matrix uses a-Si Thin Film Transistor as a switching device. This TFT LCD has a 15 inch diagonally measured active display area with XGA resolution (1,024 horizontal by 768 vertical pixels array).

1.2 Features

- Supported XGA Resolution
- LVDS Interface
- Compatible with RoHS standard

1.3 Product Summary

Items	Specifications	Unit
Screen Diagonal	15.0	Inch
Active Area (H x V)	304.128 x 228.096	mm
Number of Pixels (H x V)	1,024 x 768	-
Pixel Pitch (H x V)	0.297 x 0.297	mm
Pixel Arrangement	R.G.B. Vertical Stripe	-
Display Mode	Normally White	-
White Luminance	500(Typ.)	cd /m ²
Contrast Ratio	800(Typ.)	-
Response Time	25(Typ.)	ms
Input Voltage	3.3(Typ.)	V
Power Consumption	13.8 (Max.)	W
Weight	930(Typ.) 960 (Max.)	g
Outline Dimension (H x V x D)	326.5(Typ.) x 253.5(Typ.) x 12.5 (Max.)	mm
Electrical Interface (Logic)	LVDS	-
Support Color	16.2M	-
NTSC	70 (Typ.)	%
Viewing Direction	6 O'clock	-
Surface Treatment	Anti-glare, Hard-Coating (3H)	-

Document Name	M150GNN2 R0 Customer Approval Specification			Page 5 of 24	
Document No.	A-M150GNN2-R0-468-02	Made/Revised Date	2019/04/24	Ver.	00

1.4 Functional Block Diagram

Show the functional block diagram of the LCD module.

Figure 1 Block Diagram

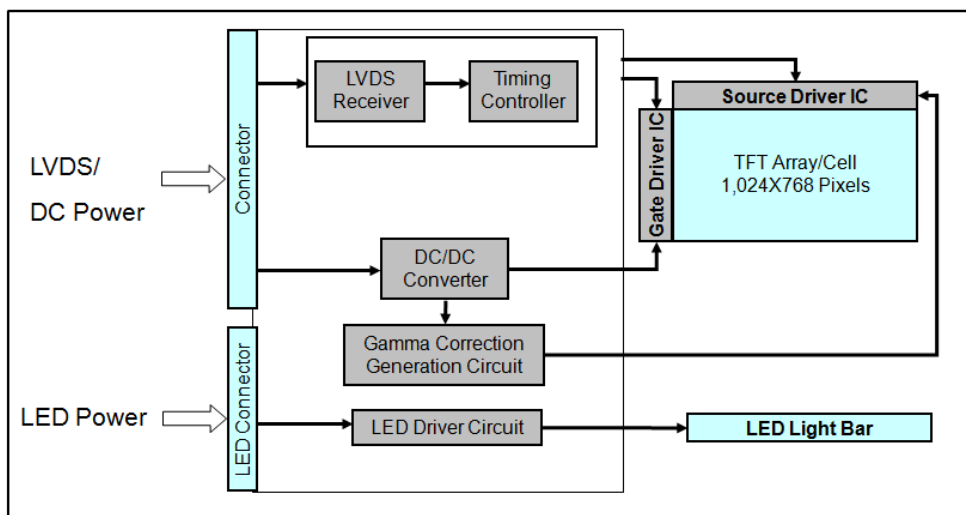

1.5 Pixel Mapping

Figure2 Pixel Mapping

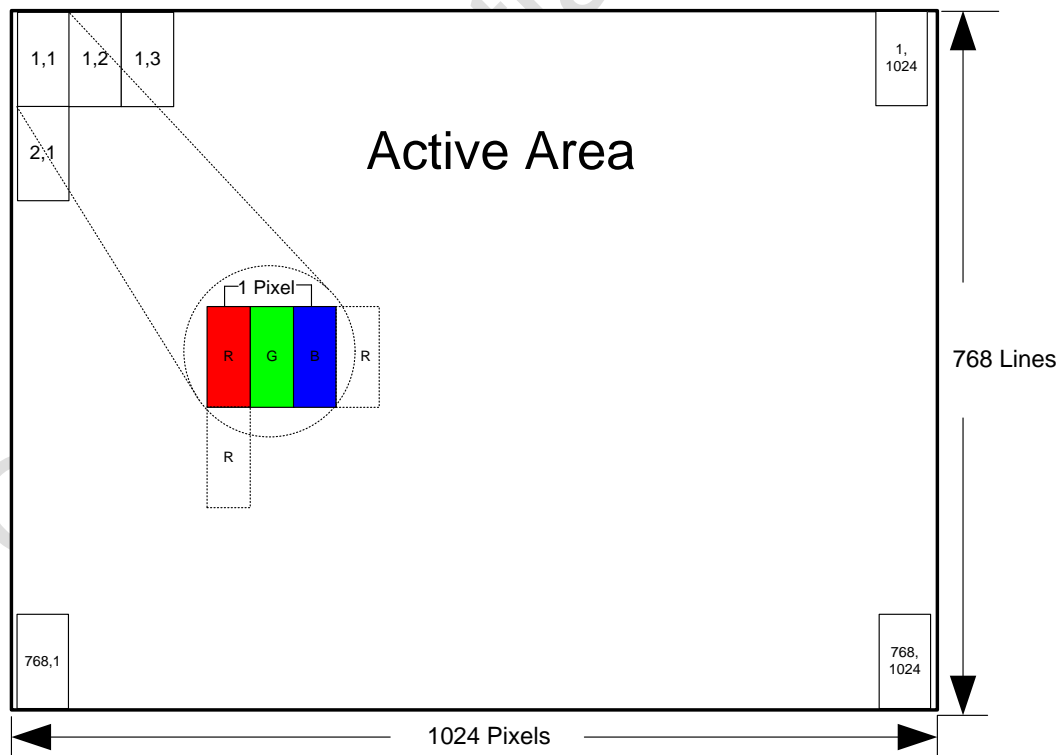

Document Name	M150GNN2 R0 Customer Approval Specification			Page 6 of 24	
Document No.	A-M150GNN2-R0-468-02	Made/Revised Date	2019/04/24	Ver.	00

2.0 Absolute Maximum Ratings

Table 1 Absolute Ratings of Environment

Item	Symbol	Min.	Max.	Unit	Conditions
Supply Voltage	V_{DD}	-0.5	5	V	(1) (2) (3) (4)
Operating Temperature	T_{gs}	-30	85	°C	
Storage Temperature	T_a	-30	85	°C	

Note (1) All the parameters specified in the table are absolute maximum rating values that may cause faulty operation or unrecoverable damage, if exceeded. It is recommended to follow the typical value.

Note (2) All the contents of electro-optical specifications and display fineness are guaranteed under Normal Conditions. All the display fineness should be inspected under normal conditions. Normal conditions are defined as follow: Temperature: 25°C, Humidity: 55± 10%RH.

Note (3) Unpredictable results may occur when it was used in extreme conditions. T_a = Ambient Temperature, T_{gs} = Glass Surface Temperature. All the display fineness should be inspected under normal conditions.

Note (4) Temperature and relative humidity range are shown in the figure below. Wet bulb temperature should be lower than 39°C, and no condensation of water. Besides, protect the module from static electricity.

Figure 3 Absolute Ratings of Environment of the LCD Module

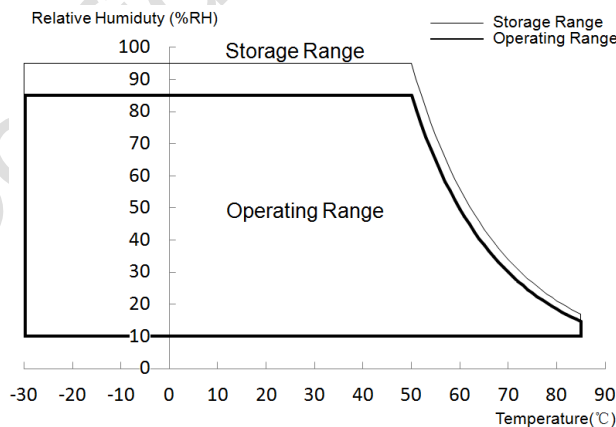

Document Name	M150GNN2 R0 Customer Approval Specification			Page 7 of 24	
Document No.	A-M150GNN2-R0-468-02	Made/Revised Date	2019/04/24	Ver.	00

3.0 Optical Characteristics

The optical characteristics are measured under stable conditions as following notes

Table 2 Optical Characteristics

Item	Conditions	Min.	Typ.	Max.	Unit	Note		
Viewing Angle (CR>10)	Horizontal	θ_{x+}	70	80	-	degree (1),(2),(3),(4),(8)		
		θ_{x-}	70	80	-			
	Vertical	θ_{y+}	70	80	-			
		θ_{y-}	60	80	-			
Contrast Ratio	Center	450	800	-	-	(1),(2),(4),(8) $\theta_x=\theta_y=0^\circ$		
Response Time	Rising + Falling	-	25	-	ms	(1),(2),(5),(8) $\theta_x=\theta_y=0^\circ$		
Color Chromaticity (CIE1931)	Red x	Typ. -0.03	0.631	Typ. +0.03	-	(1),(2),(3),(8) $\theta_x=\theta_y=0^\circ$		
	Red y		0.354		-			
	Green x		0.318		-			
	Green y		0.630		-			
	Blue x		0.147		-			
	Blue y		0.075		-			
	White x		0.255		0.305		0.355	-
	White y		0.275		0.325		0.375	-
NTSC	-	-	70	-	%	(1),(2),(3),(8) $\theta_x=\theta_y=0^\circ$		
White Luminance	Center	400	500	-	cd/m ²	(1),(2),(6),(8) $\theta_x=\theta_y=0^\circ$		
Luminance Uniformity	9 Points	75	80	-	%	(1),(2),(7),(8) $\theta_x=\theta_y=0^\circ$		

Note (1) Measurement Setup:

The LCD module should be stabilized at given temperature(25°C) for 30 minutes to avoid abrupt temperature changing during measuring. In order to stabilize the luminance, the measurement should be executed after lighting backlight for 30 minutes in a windless room.

Document Name	M150GNN2 R0 Customer Approval Specification			Page 8 of 24	
Document No.	A-M150GNN2-R0-468-02	Made/Revised Date	2019/04/24	Ver.	00

Figure 4 Measurement Setup

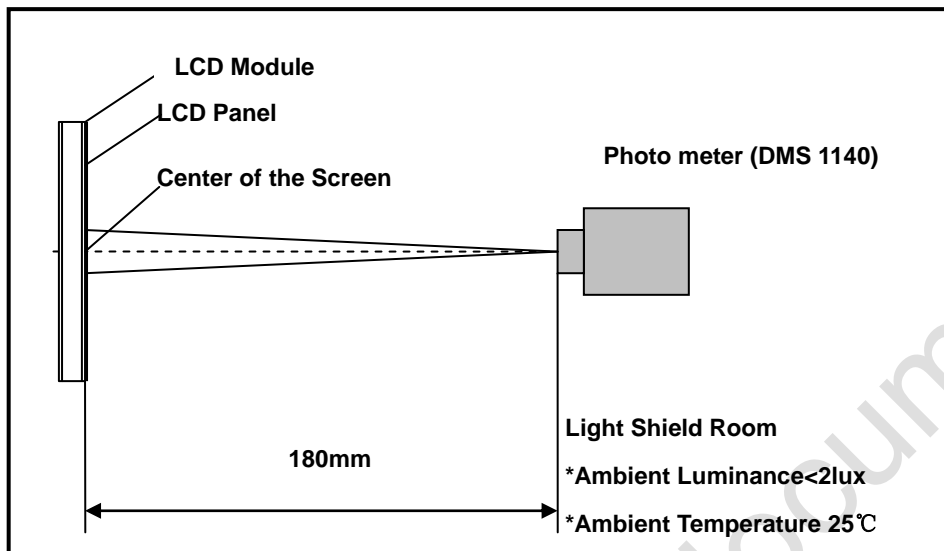

Note (2) The LED input parameter setting as:

I_LED:240mA;

PWM_LED: Duty 100 %

Note (3) Definition of Viewing Angle

Figure 5 Definition of Viewing Angle

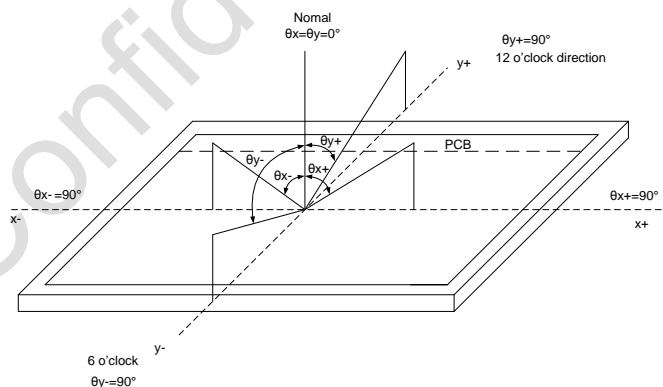

Note (4) Definition Of Contrast Ratio (CR)

The contrast ratio can be calculated by the following expression

$$\text{Contrast Ratio (CR)} = L_{255} / L_0$$

L255: Luminance of gray level 255, L0: Luminance of gray level 0

Note (5) Definition Of Response Time (T_R , T_F)

Document Name	M150GNN2 R0 Customer Approval Specification			Page 9 of 24	
Document No.	A-M150GNN2-R0-468-02	Made/Revised Date	2019/04/24	Ver.	00

Figure 6 Definition of Response Time

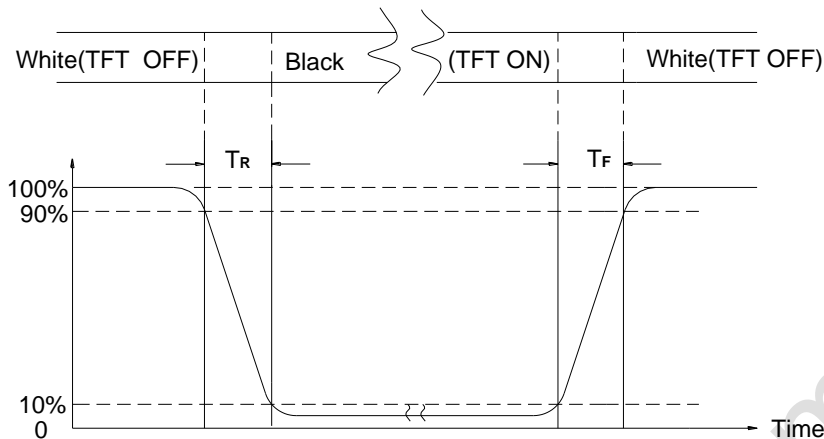

Note (6) Definition Of Luminance White

Measure the luminance of gray level 255 at center point (Ref.: Active Area)

Note (7) Definition Of Luminance Uniformity (Ref.: Active Area)

Measure the luminance of gray level 255 at 9 points.

Luminance Uniformity= $\text{Min.}(L1, L2, \dots L9) / \text{Max.}(L1, L2, \dots L9)$

H—Active Area Width, V—Active Area Height, L—Luminance

Figure 7 Measurement Locations of 9 Points

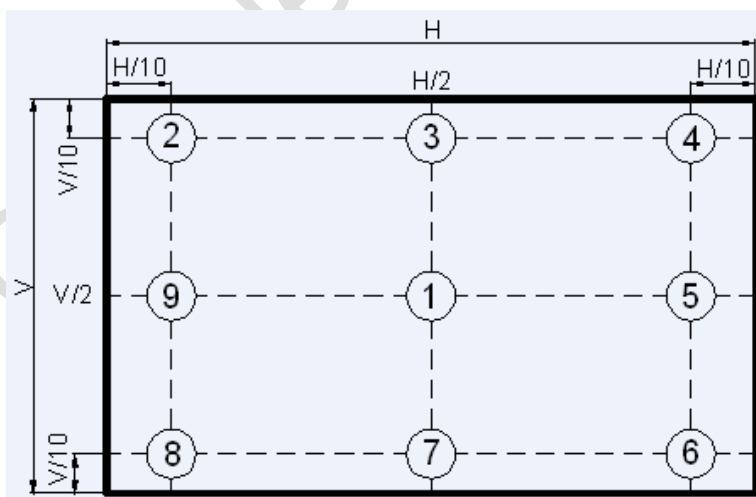

Note (8) All optical data based on IVO given system & nominal parameter & testing machine in this document.

Document Name	M150GNN2 R0 Customer Approval Specification			Page 10 of 24	
Document No.	A-M150GNN2-R0-468-02	Made/Revised Date	2019/04/24	Ver.	00

4.0 Electrical Characteristics

4.1 Interface Connector

Table 3 Signal Connector Type

Item	Description
Type / Part Number	MSB240420HD
Mating Model Number	P240420 or compatible

Table 4 Signal Connector Pin Assignment

Pin No.	Symbol	Description	Remarks
1	VDD	Power Supply, 3.3V (typical)	
2	VDD	Power Supply, 3.3V (typical)	
3	VSS	Ground	
4	REV	Reverse Scan selection	Note
5	Rin1-	-LVDS differential data input (R0-R5,G0)	
6	Rin1+	+LVDS differential data input (R0-R5,G0)	
7	VSS	Ground	
8	Rin2-	-LVDS differential data input (G1-G5,B0-B1)	
9	Rin2+	+LVDS differential data input (G1-G5,B0-B1)	
10	VSS	Ground	
11	Rin3-	-LVDS differential data input (B2-B5,HS,VS,DE)	
12	Rin3+	+LVDS differential data input (B2-B5,HS,VS,DE)	
13	VSS	Ground	
14	CIKIN-	-LVDS differential clock input	
15	CIKIN+	+LVDS differential clock input	
16	GND	Ground	
17	Rin4-	-LVDS differential data input (R6-R7,G6-G7,B6-B7)	
18	Rin4+	+VDS differential data input (R6-R7,G6-G7,B6-B7)	
19	VSS	Ground	
20	NC	Not connect	

Document Name	M150GNN2 R0 Customer Approval Specification			Page 11 of 24	
Document No.	A-M150GNN2-R0-468-02	Made/Revised Date	2019/04/24	Ver.	00

Note: I REV = LOW/NC

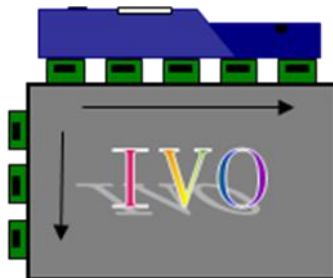

II REV = High

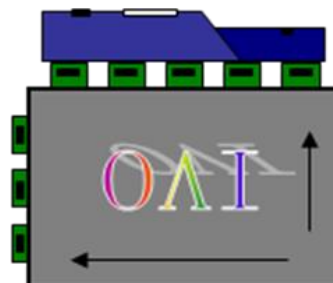

Table 5 LED Connector Name / Designation

Item	Description
Connector Name/Designation	LED Driver Connector
Manufacturer	STM or compatible
Connector Model Number	MSB24038P5A or compatible
Mating Model Number	P24038P5A or compatible

Table 6 LED Connector Pin Assignment

Pin No.	Symbol	Description	Remark
1	Vcc	12V	-
2	GND	GND	-
3	Enable	5V-On / 0V-Off	-
4	Dimming	PWM Dimming or Analog Dimming	-
5	NC	NC	-

Document Name	M150GNN2 R0 Customer Approval Specification			Page 12 of 24	
Document No.	A-M150GNN2-R0-468-02	Made/Revised Date	2019/04/24	Ver.	00

4.2 Signal Electrical Characteristics

4.2.1 Signal Electrical Characteristics For LVDS Receiver

The built-in LVDS receiver is compatible with (ANSI/TIA/TIA-644) standard.

Table 7 LVDS Receiver Electrical Characteristics

Parameter	Symbol	Min.	Typ.	Max.	Unit	Conditions
Differential Input High Threshold	Vth	-	-	+100	mV	V _{CM} =+1.2V
Differential Input Low Threshold	Vtl	-100	-	-	mV	V _{CM} =+1.2V
Magnitude Differential Input Voltage	V _{ID}	200	-	600	mV	-
Common Mode Voltage	V _{CM}	-	1.2	1.85- V _{ID} /2	V	-
Input Leakage Current	/	-10	-	10	mV	V _{CM} =+1.2V

Note (1) Input signals shall be low or Hi- resistance state when VDD is off.

Note (2) All electrical characteristics for LVDS signal are defined and shall be measured at the interface connector of LCD.

Figure 8 Voltage Definitions

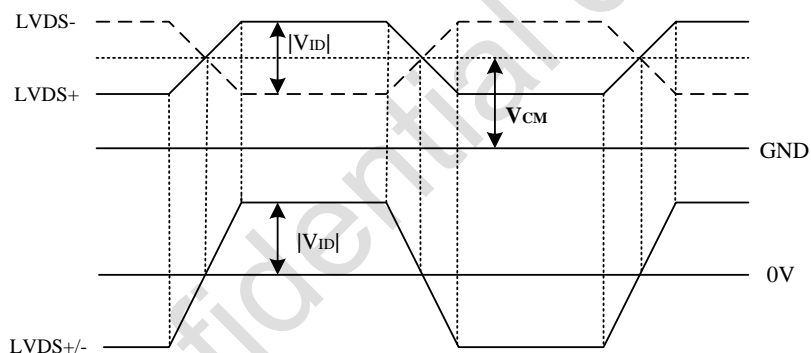
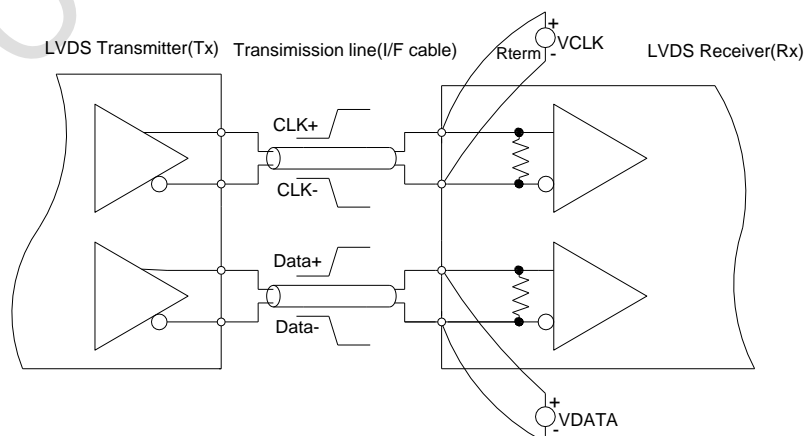
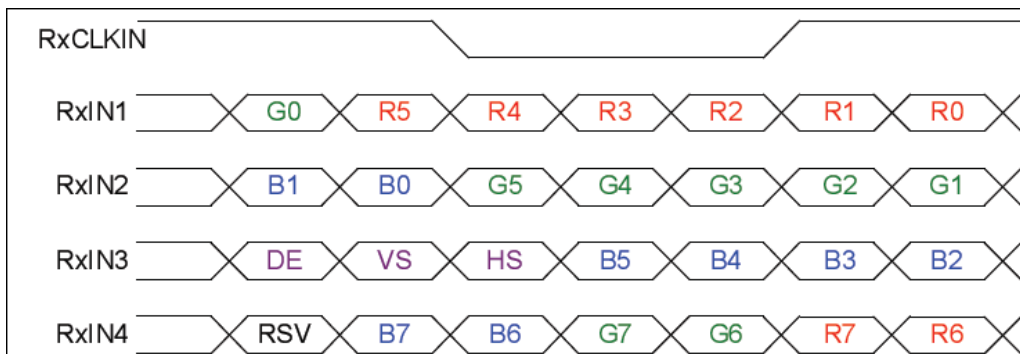

Figure 9 Measurement System



Document Name	M150GNN2 R0 Customer Approval Specification			Page 13 of 24	
Document No.	A-M150GNN2-R0-468-02	Made/Revised Date	2019/04/24	Ver.	00

Figure 10 Data Mapping



Note1 : Follow SPWG

Note2 : R/G/B data7 : MSB , R/G/B data0 : LSB

4.2.2 LVDS Receiver Internal Circuit

Figure 11 shows the internal block diagram of the LVDS receiver. This LCD module equips termination resistors for LVDS link.

Figure 11 LVDS Receiver Internal Circuit

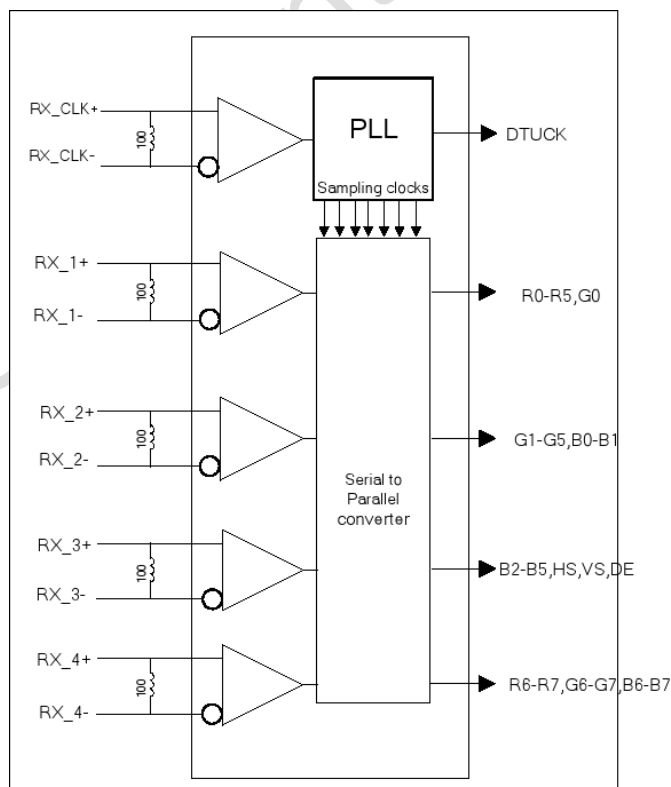

Document Name	M150GNN2 R0 Customer Approval Specification			Page 14 of 24	
Document No.	A-M150GNN2-R0-468-02	Made/Revised Date	2019/04/24	Ver.	00

4.3 Interface Timings

Table 8 Interface Timings

Parameter	Symbol	Min.	Typ.	Max.	Unit
LVDS Clock Frequency	Fclk	50	65	80	MHz
H Total Time	HT	1,056	1,344	1,720	Clocks
H Active Time	HA	1,024			Clocks
V Total Time	VT	772	806	990	Lines
V Active Time	VA	768			Lines
Frame Rate	FV	55	60	70	Hz

Note (1) Synchronization Method: DE only

Note (2) H Blank area and V Blank area can not be changed at every frame

Document Name	M150GNN2 R0 Customer Approval Specification			Page 15 of 24	
Document No.	A-M150GNN2-R0-468-02	Made/Revised Date	2019/04/24	Ver.	00

4.4 Input Power Consumption

Input power specifications are as follows.

Table 9 Input Power Consumption

Parameter	Symbol	Min.	Typ.	Max.	Unit	Note	
System Power Supply							
LCD Drive Voltage (Logic)	V_{DD}	3.0	3.3	3.6	V	(1), (2)	
VDD Current	Black Pattern	I_{DD}	-	0.25	-	A	(1),(2),(3)
VDD Power Consumption	Black Pattern	P_{DD}	-	-	1.3	W	
Rush Current		I_{Rush}	-	-	0.75	A	(1), (4)
Allowable Logic/LCD Drive Ripple Voltage		V_{VDD-RP}	-	-	200	mV	(1)
LED Power Supply							
LED Input Voltage		V_{LED}	10.8	12	12.6	V	(1),(2)
LED Power Consumption		P_{LED}	-	-	12.5	W	(1),(5)
PWM Signal Voltage	High	V_{PWM}	4.5	5	5.5	V	(1),(2)
	Low		-	-	0.8		
LED Enable Voltage	High	V_{LED_EN}	2.0	5	5.5	V	
	Low		-	-	0.8		
Input PWM Frequency		F_{PWM}	200	-	20K	Hz	(1),(6),(7) Ddim ≥ 5%
LED Life Time		LT	50,000	-	-	Hours	(1),(8)

Note (1) All of the specifications are guaranteed under normal conditions. Normal conditions are defined as follow: Temperature: 25°C, Humidity: 55± 10%RH.

Note (2) All of the absolute maximum ratings specified in the table, if exceeded, may cause faulty operation or unrecoverable damage. It is recommended to follow the typical value.

Note (3) The specified V_{DD} current and power consumption are measured under the $V_{DD} = 3.3$ V, $F_v = 60$ Hz condition and Black Pattern.

Note (4) The figures below is the measuring condition of V_{DD} . Rush current can be measured when T_{RUSH} is 0.5 ms.

Document Name	M150GNN2 R0 Customer Approval Specification			Page 16 of 24	
Document No.	A-M150GNN2-R0-468-02	Made/Revised Date	2019/04/24	Ver.	00

Figure 12 V_{DD} Rising Time

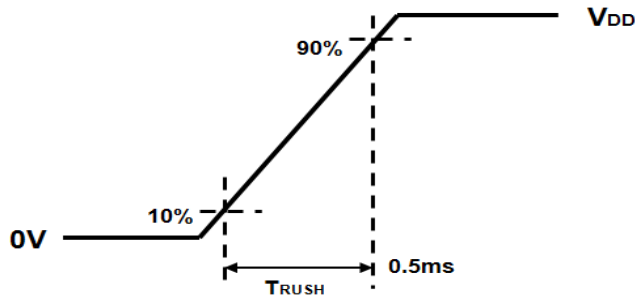

Note (5) The power consumption of LED Driver are under the V_{LED} = 12.0V, Dimming of Max luminance.

Note (6) Although acceptable range as defined, the dimming ratio is not effective at all conditions. The PWM frequency should be fixed and stable for more consistent luminance control at any specific level desired.

Note (7) The operation of LED Driver below minimum dimming ratio may cause flickering or reliability issue.

Note (8) The life time is determined as the sum of the lighting time till the luminance of LCD at the typical LED current reducing to 50% of the minimum value under normal operating condition.

Document Name	M150GNN2 R0 Customer Approval Specification			Page 17 of 24	
Document No.	A-M150GNN2-R0-468-02	Made/Revised Date	2019/04/24	Ver.	00

4.5 Power ON/OFF Sequence

VDD power on/off sequence is as follows. Interface signals are also shown in the chart. Signals from any system shall be Hi-Z state or low level when VDD is off.

Figure 13 Power Sequence

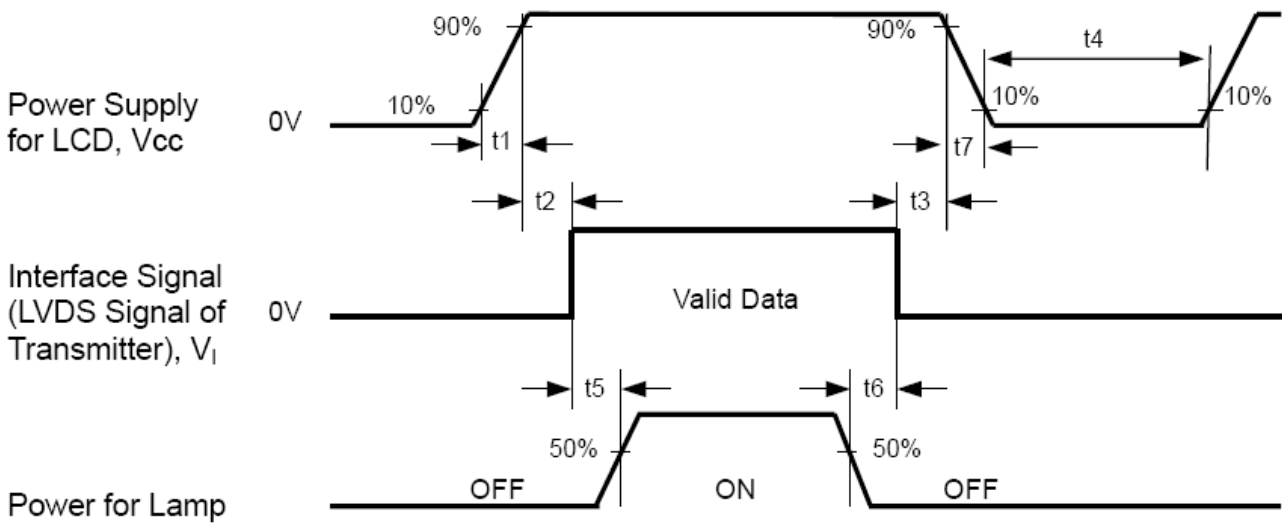

Table 10 Power Sequencing Requirements

Parameter	Symbol	min	Typ.	max	Unit
VDD Rise Time	T1	0.5	-	10	ms
VDD Good to Signal Valid	T2	0	-	20	ms
Signal Disable to Power Down	T3	0	-	1000	ms
Power Off	T4	1000	-	-	ms
Signal Valid to Backlight On	T5	300	-	-	ms
Backlight Off to Signal Disable	T6	200	-	-	ms
VDD Fall Time	T7	0	-	100	ms

Document Name	M150GNN2 R0 Customer Approval Specification			Page 18 of 24	
Document No.	A-M150GNN2-R0-468-02	Made/Revised Date	2019/04/24	Ver.	00

5.0 Mechanical Characteristics

5.1 Outline Drawing

Figure 14 Reference Outline Drawing (Front Side)

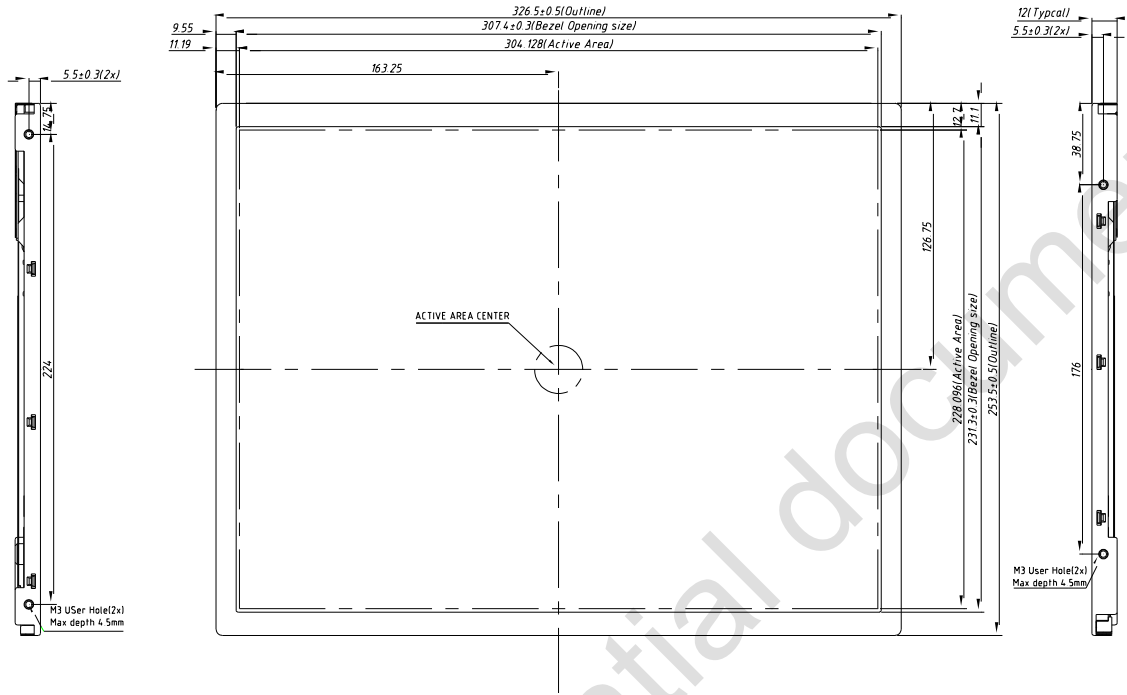
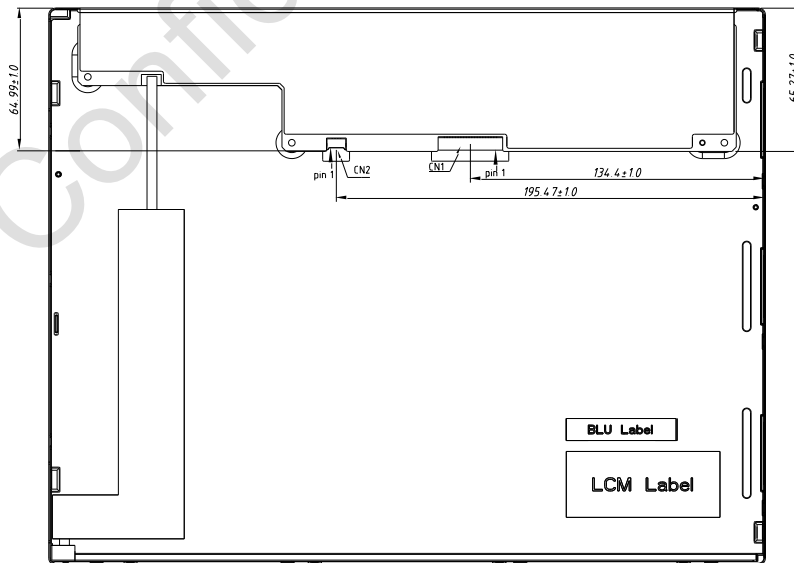

Figure 15 Reference Outline Drawing (Back Side)



Document Name	M150GNN2 R0 Customer Approval Specification			Page 19 of 24	
Document No.	A-M150GNN2-R0-468-02	Made/Revised Date	2019/04/24	Ver.	00

5.2 Dimension Specifications

Table 11 Module Dimension Specifications

Item	Min.	Typ.	Max.	Unit
Width	326.0	326.5	327.0	mm
Height	253.0	253.5	254.0	mm
Thickness	11.5	12.0	12.5	mm
Weight	-	930	960	g

Document Name	M150GNN2 R0 Customer Approval Specification			Page 20 of 24	
Document No.	A-M150GNN2-R0-468-02	Made/Revised Date	2019/04/24	Ver.	00

6.0 Reliability Conditions

Table 12 Reliability Condition

Item		Package	Test Conditions		Note.
High Temperature Operation Test		Module	$T_{gs}=85^{\circ}\text{C}$, 500hrs		(1),(2),(3),(4)
Low Temperature Operating Test		Module	$T_a=-30^{\circ}\text{C}$, 500hrs		(1),(2),(3),(4)
High Temp./High Humidity Operating Test		Module	$T_{gs}=50^{\circ}\text{C}$, 85%, 500hrs		(1),(2),(3),(4)
High Temp./High Humidity Storage Test		Module	$T_a=50^{\circ}\text{C}$, 95%, 500hrs		(1),(3),(4)
Thermal Shock Non-operation Test		Module	$-20^{\circ}\text{C} \sim 60^{\circ}\text{C}$, 1hr/each cycle, 100cycles		(1),(3),(4)
Shock Non-operating Test		Module	3 shock in each direction Peak acceleration:981m/s ² Half Sine Wave; 6ms		(1),(3),(5)
Vibration Non-operating Test		Module	1.5G , 10~500 Hz , x · y · z each axis/1h		
ESD Test	operating	Module	contact	$\pm 8 \text{ KV}$, 150pF(330Ohm)	(1),(2),(6)
			air	$\pm 15 \text{ KV}$, 150pF(330Ohm)	
	non-operating		contact	$\pm 10 \text{ KV}$, 150pF(330Ohm)	(1),(6)
			air	$\pm 20 \text{ KV}$, 150pF(330Ohm)	

Note (1) A sample can only have one test. Outward appearance, image quality and optical data can only be checked at normal conditions according to the IVO document before reliable test. Only check the function of the module after reliability test.

Note (2) The setting of electrical parameters should follow the typical value before reliability test.

Note (3) During the test, it is unaccepted to have condensate water remains. Besides, protect the module from static electricity.

Note (4) The sample must be released for 24 hours under normal conditions before judging.

Furthermore, all the judgment must be made under normal conditions. Normal conditions are defined as follow: Temperature: 25°C , Humidity: $55 \pm 10\% \text{RH}$. T_a = Ambient Temperature, T_{gs} = Glass Surface Temperature.

Note (5) The module should be fixed firmly in order to avoid twisting and bending.

Note (6) It could be regarded as pass, when the module recovers from function fault caused by ESD after resetting.

Document Name	M150GNN2 R0 Customer Approval Specification			Page 21 of 24	
Document No.	A-M150GNN2-R0-468-02	Made/Revised Date	2019/04/24	Ver.	00

7.0 Package Specification

Figure 16 Packing Method

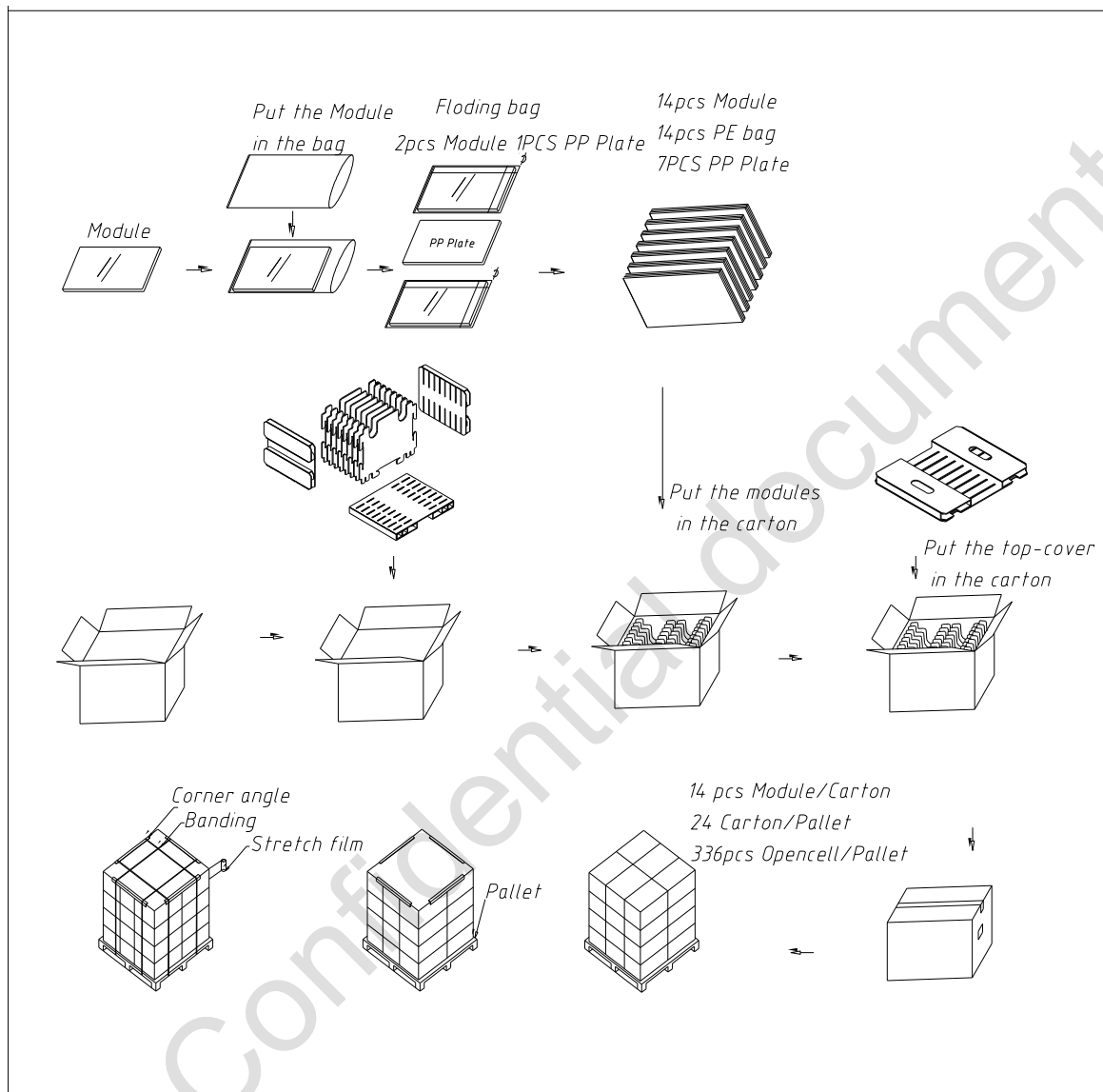

Components Material	Module	Carton	Antistaticbag	Protect film	PP Plate	Pallet	Weight
Matrrial Size(mm)	326.5*253.5*12	406*331*343	350*330*0.06	317*241*0.1	325*252*3	1100*890*120	18Kg
Amount (Pcs/Carton)	14	1	14	14	7	1/24	14Pcs Module (include packing)

Document Name	M150GNN2 R0 Customer Approval Specification			Page 22 of 24	
Document No.	A-M150GNN2-R0-468-02	Made/Revised Date	2019/04/24	Ver.	00

8.0 Lot Mark

Module name

Development product name

23 Product code Overseas

Lot mark

Note: This picture is only a sample.

8.1 20 Lot Mark

1	2	3	4	5	6	7	8	9	10	11	12	13	14	15	16	17	18	19	20
---	---	---	---	---	---	---	---	---	----	----	----	----	----	----	----	----	----	----	----

Code1,2,4,5,6,7,8,9,10,11,16: IVO internal flow control code.

Code3: Production location.

Code12: Production year.

Code13: Production month.

Code14, 15: Production date.

Code17, 18, 19, 20: Serial number.

8.2 23 Product Barcode

1	2	3	4	5	6	7	8	9	10	11	12	13	14	15	16	17	18	19	20	21	22	23
---	---	---	---	---	---	---	---	---	----	----	----	----	----	----	----	----	----	----	----	----	----	----

Code 1,2: Manufacture District.

Code 3,4,5,6,7: IVO internal module name.

Code 8,9,10,13,16: IVO internal flow control code.

Code 11,12: Cell location Suzhou, China defined as "KS".

Code 14, 15: Module location Kunshan, China defined as "KS"; Yangzhou, China defined as "YZ"; Shenzhen, China defined as "SE"; Zhuhai, China defined as "ZH"; Suzhou, China defined as "SZ".

Code 17,18,19 : Year, Month, Day refer to Note(1), Note(2) and Note(3).

Note (1) Production Year

Year	2006	2007	2008	2009	2010	2011	2012	2013	2035
Mark	6	7	8	9	A	B	C	D	Z

Note (2) Production Month

Month	Jan.	Feb.	Mar.	Apr.	May.	Jun.	Jul.	Aug.	Sep.	Oct	Nov.	Dec.
Mark	1	2	3	4	5	6	7	8	9	A	B	C

Note (3) Production Day: 1~V.

Code 20~23 : Serial Number.

Document Name	M150GNN2 R0 Customer Approval Specification			Page 23 of 24	
Document No.	A-M150GNN2-R0-468-02	Made/Revised Date	2019/04/24	Ver.	00

9.0 General Precaution

9.1 Using Restriction

This product is not authorized for using in life supporting systems, aircraft navigation control systems, military systems and any other appliance where performance failure could be life-threatening or lead to be catastrophic.

9.2 Operation Precaution

(1)The LCD product should be operated under normal conditions.

Normal conditions are defined as below:

Temperature: 25°C

Humidity: 55±10%

Display pattern: continually changing pattern (Not stationary)

(2) Brightness and response time depend on the temperature. (It needs more time to reach normal brightness in low temperature.)

(3) It is necessary for you to pay attention to condensation when the ambient temperature drops suddenly. Condensate water would damage the polarizer and electrical contacted parts of the module. Besides, smear or spot will remain after condensate water evaporating.

(4) If the absolute maximum rating value was exceeded, it may damage the module.

(5) Do not adjust the variable resistor located on the module.

(6) Sufficient suppression to the electromagnetic interference shall be done by system manufacturers. Grounding and shielding may be important to minimize the interference.

(7) Image sticking may occur when the module displayed the same pattern for long time.

(8) Do not connect or disconnect the module in the “power on” condition. Power supply should always be turned on/off by the “power on/off sequence”

(9) Ultra-violet ray filter is necessary for outdoor operation.

9.3 Mounting Precaution

(1) All the operators should be electrically grounded and with Ion-blown equipment turning on when mounting or handling. Dressing finger-stalls out of the gloves is important for keeping the panel clean during the incoming inspection and the process of assembly.

(2) It is unacceptable that the material of cover case contains acetic or chloric. Besides, any other material that could generate corrosive gas or cause circuit break by electro-chemical reaction is not desirable.

(3) The case on which a module is mounted should have sufficient strength so that external force is not transmitted to the module directly.

(4) It is obvious that you should adopt radiation structure to satisfy the temperature specification.

(5) So as to acquire higher luminance, the cable between the back light and the inverter of the power supply should be connected directly with a minimize length.

(6) It should be attached to the system tightly by using all holes for mounting, when the module is assembled. Be careful not to apply uneven force to the module, especially to the PCB on the back.

Document Name	M150GNN2 R0 Customer Approval Specification			Page 24 of 24	
Document No.	A-M150GNN2-R0-468-02	Made/Revised Date	2019/04/24	Ver.	00

- (7) A transparent protective film needs to be attached to the surface of the module.
- (8) Do not press or scratch the polarizer exposed with anything harder than HB pencil lead. In addition, don't touch the pin exposed with bare hands directly.
- (9) Clean the polarizer gently with absorbent cotton or soft cloth when it is dirty.
- (10) Wipe off saliva or water droplet as soon as possible. Otherwise, it may cause deformation and fading of color.
- (11) Desirable cleaners are IPA (Isopropyl Alcohol) or hexane. Do not use Ketone type materials (ex. Acetone), Ethyl alcohol, Toluene, Ethyl acid or Methyl chloride. It might permanent damage to the polarizer due to chemical reaction.
- (12) Do not disassemble or modify the module. It may damage sensitive parts in the LCD module, and cause scratches or dust remains. IVO does not warrant the module, if you disassemble or modify the module.

9.4 Handling Precaution

- (1) Static electricity will generate between the film and polarizer, when the protection film is peeled off. It should be peeled off slowly and carefully by operators who are electrically grounded and with Ion-blown equipment turning on. Besides, it is recommended to peel off the film from the bonding area.
- (2) The protection film is attached to the polarizer with a small amount of glue. When the module with protection film attached is stored for a long time, a little glue may remain after peeling.
- (3) If the liquid crystal material leaks from the panel, keep it away from the eyes and mouth. In case of contact with hands, legs or clothes, it must be clean with soap thoroughly.

9.5 Storage Precaution

When storing modules as spares for long time, the following precautions must be executed.

- (1) Store them in a dark place. Do not expose to sunlight or fluorescent light. Keep the temperature between 5°C and 35°C at normal humidity.
- (2) The polarizer surface should not come in contact with any other object. It is recommended that they be stored in the container in which they were shipped.
- (3) It is recommended to use it in a short-time period, after it's unpacked. Otherwise, we would not guarantee the quality.

9.6 Others

When disposing LCD module, obey the local environmental regulations.
mental regulations.