



Document Title	M070SWP1 R5 Customer Approved Specification	Page No.	1/24
Document No.		Issue date	2016/01/04
		Revision	00

Customer Approved Specification

To:

Product Name: M070SWP1 R5

Document Issue Date: 2016/01/04

Customer	InfoVision Optoelectronics
<u>SIGNATURE</u>	<u>SIGNATURE</u>
_____	REVIEWED BY CQM
_____	_____
_____	PREPARED BY FAE
_____	_____
Please return 1 copy for your confirmation with your signature and comments.	

- Note: 1. Please contact InfoVision Company, before designing your product based on this product.
2. The information contained herein is presented merely to indicate the characteristics and performance of our products. No responsibility is assumed by IVO for any intellectual property claims or other problems that may result from application based on the module described herein.



InfoVision Optoelectronics (Kunshan)Co., Ltd.

Document Title	M070SWP1 R5 Customer Approved Specification		Page No.	2/24	
Document No.		Issue date	2016/01/04	Revision	00

Revision	Date	Page	Old Description	New Description	Remark
00	2016/01/04			First issue	



Document Title	M070SWP1 R5 Customer Approved Specification	Page No.	3/24		
Document No.		Issue date	2016/01/04	Revision	00

CONTENTS

1.0 GENERAL DESCRIPTIONS.....	4
2.0 ABSOLUTE MAXIMUM RATINGS	6
3.0 OPTICAL CHARACTERISTICS	7
4.0 ELECTRICAL CHARACTERISTICS	11
5.0 MECHANICAL CHARACTERISTICS.....	18
6.0 RELIABILITY CONDITIONS.....	20
7.0 PACKAGE SPECIFICATION.....	20
8.0 LOT MARK	22
9.0 GENERAL PRECAUTION	23



Document Title	M070SWP1 R5 Customer Approved Specification	Page No.	4/24		
Document No.		Issue date	2016/01/04	Revision	00

1.0 General Descriptions

1.1 Introduction

The M070SWP1 R5 is a color active matrix thin film transistor (TFT) liquid crystal display (LCD) that uses amorphous silicon TFT as a switching device. This model is composed of a TFT LCD panel, a driver circuit and a backlight system. This TFT LCD has a 7.0 inch diagonally measured active display area with WVGA resolution (800 horizontal by 480 vertical pixels array).

1.2 Features

- Supported WVGA Resolution
- TTL Interface
- Compatible with RoHS Standard

1.3 Product Summary

Items	Specifications	Unit
Screen Diagonal	7.0	inch
Active Area (H x V)	153.60 x86.64	mm
Number of Pixels (H x V)	800x480	-
Pixel Pitch (H x V)	0.1920x0.1805	mm
Pixel Arrangement	R.G.B. Vertical Stripe	-
Display Mode	Normally White	-
White Luminance	350 (Typ.)	cd /m ²
Contrast Ratio	500 (Typ.)	-
Response Time	16 (Typ.)	ms
Input Voltage	3.3 (Typ.)	V
Weight	193.9 (Max.)	g
Outline Dimension (H x V x D)	165.00 (Typ.) x 104.00(Typ.) x 7.90 (Max.)	mm
Electrical Interface (Logic)	TTL	-
Support Color	6 bits+HFRC	-
NTSC	50 (Typ.)	%
Viewing Direction	6 O'clock	-
Surface Treatment	Anti-glare, Hard-Coating (3H) with EWV film	-

Document Title	M070SWP1 R5 Customer Approved Specification		Page No.	5/24	
Document No.		Issue date	2016/01/04	Revision	00

1.4 Functional Block Diagram

Figure 1 shows the functional block diagram of the LCD module.

Figure 1 Block Diagram

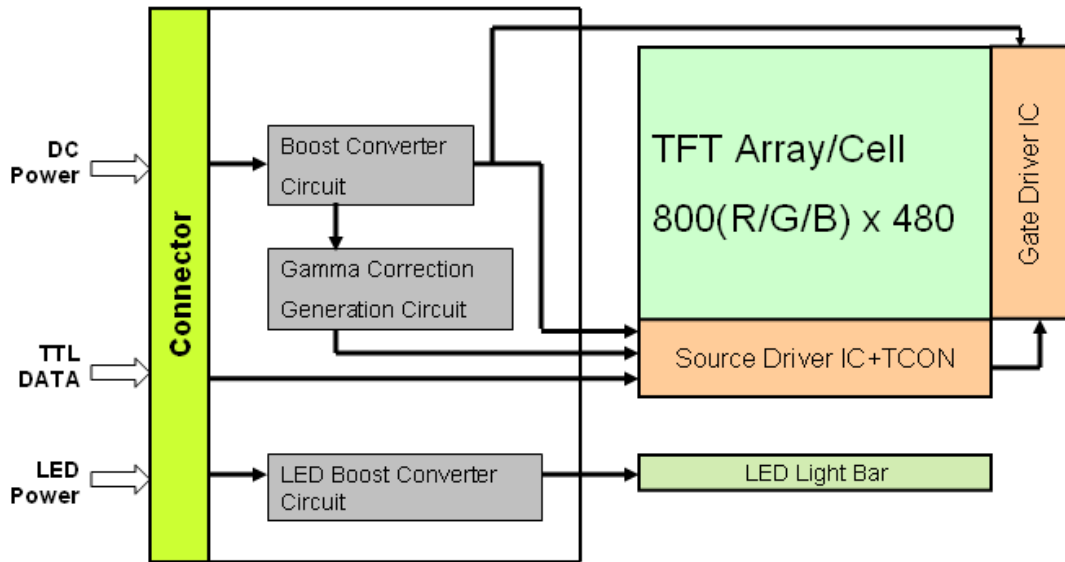

1.5 Pixel Mapping

Figure2 Pixel Mapping

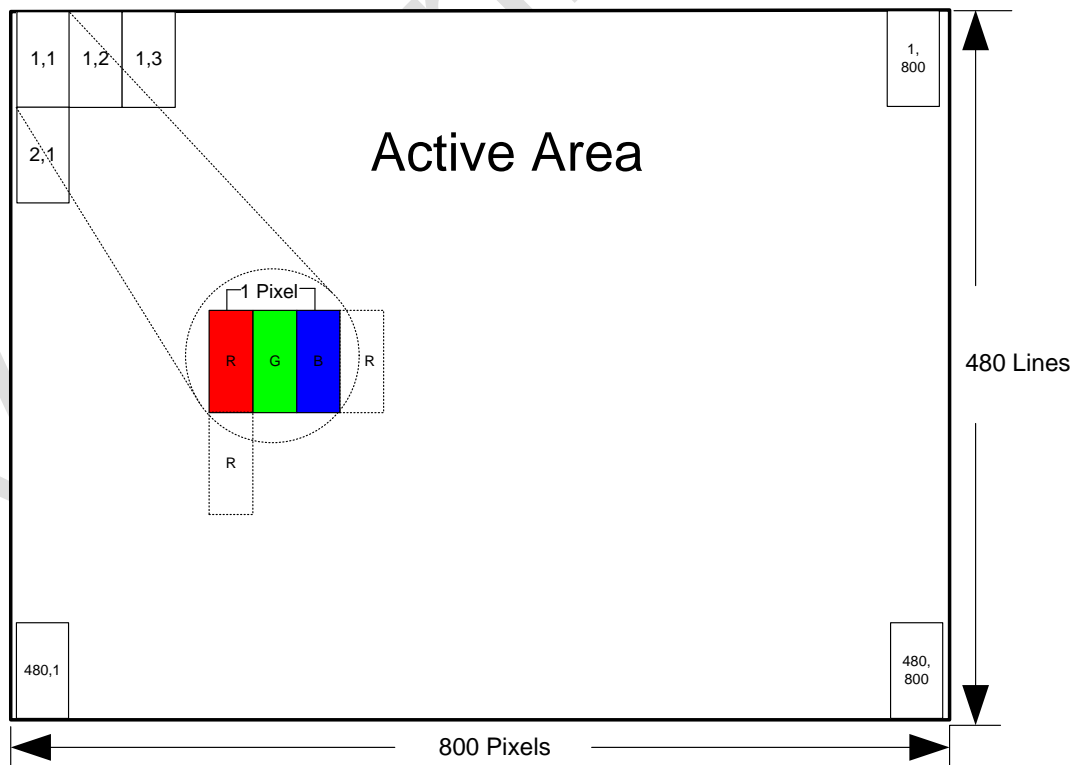



Document Title	M070SWP1 R5 Customer Approved Specification		Page No.	6/24
Document No.		Issue date	2016/01/04	Revision 00

2.0 Absolute Maximum Ratings

Table 1 Electrical & Environment Absolute Rating

Item	Symbol	Min.	Max.	Unit	Note
Logic Supply Voltage	V _{DD}	-0.3	4.0	V	(1),(2)
Operating Temperature	T _{OP}	-20	70	°C	(3),(4),(5),(6)
Storage Temperature	T _{ST}	-30	80	°C	
Vibration(Non-operating)	VB	-	1.5	G	(7)
Shock(Non-operating)	Shock	-	240G	G	(8)

Note (1) Permanent damage may occur to the LCD module if beyond this specification. Functional operation should be restricted to the conditions described under normal operating conditions.

Note (2) Operating temperature 25°C, humidity 55%RH.

Note (3) (T≤40°C) Note static electricity. Maximum wet bulb temperature at 39°C or less. (T>40°C) No condensation.

Note (4) There is a possibility of causing deterioration in the irregularity and others of the screen and the display fineness though the liquid crystal module doesn't arrive at destruction when using it at 60~70°C or -10~0°C.

Note (5) There is a possibility of causing the fineness deterioration by the prolonged use in the (high temperature) humidity environment (60%RH or more).

Note (6) In the operating temperature item, the low temperature side is the ambient temperature regulations. The high temperature side is the panel surface temperature regulations.

Note (7) 10-500Hz, random vibration, 1h for X, Y, Z axis.

Note (8) 240G,2ms, half sine wave, one time for X, Y, Z axis.



Document Title	M070SWP1 R5 Customer Approved Specification			Page No.	7/24
Document No.		Issue date	2016/01/04	Revision	00

3.0 Optical Characteristics

The optical characteristics are measured under stable conditions as following notes.

Table 2 Optical Characteristics

Item	Conditions	Min.	Typ.	Max.	Unit	Note		
Viewing Angle (CR>10)	Horizontal	θ_{x+}	60	70	-	degree (1),(2),(3)		
		θ_{x-}	60	70	-			
	Vertical	θ_{y+}	40	50	-			
		θ_{y-}	50	60	-			
Contrast Ratio	Center	400	500	-	-	(1),(2),(4) $\theta_x=\theta_y=0^\circ$		
Response Time	Rising + Falling	-	16	-	ms	(1),(2),(5) $\theta_x=\theta_y=0^\circ$		
Color Chromaticity (CIE1931)	Red x	Typ. -0.03	0.598	Typ. +0.03	-	(1),(2),(3) $\theta_x=\theta_y=0^\circ$		
	Red y		0.363		-			
	Green x		0.331		-			
	Green y		0.550		-			
	Blue x		0.157		-			
	Blue y		0.098		-			
	White x		0.260		0.310		0.360	-
	White y		0.280		0.330		0.380	-
NTSC	-	47	50	-	%	(1),(2),(3) $\theta_x=\theta_y=0^\circ$		
White Luminance	Center	280	350	-	cd/m ²	(1),(2),(6) $\theta_x=\theta_y=0^\circ$		
Luminance Uniformity	9 Points	70	-	-	%	(1),(2),(7) $\theta_x=\theta_y=0^\circ$		

Note (1) Measurement Setup:

The LCD module should be stabilized at given temperature(25°C) for 15 minutes to avoid abrupt temperature change during measuring. In order to stabilize the luminance, the measurement should be executed after lighting backlight for 15 minutes in a windless room.

Document Title	M070SWP1 R5 Customer Approved Specification	Page No.	8/24
Document No.		Issue date	2016/01/04
		Revision	00

Figure 3 Measurement Setup

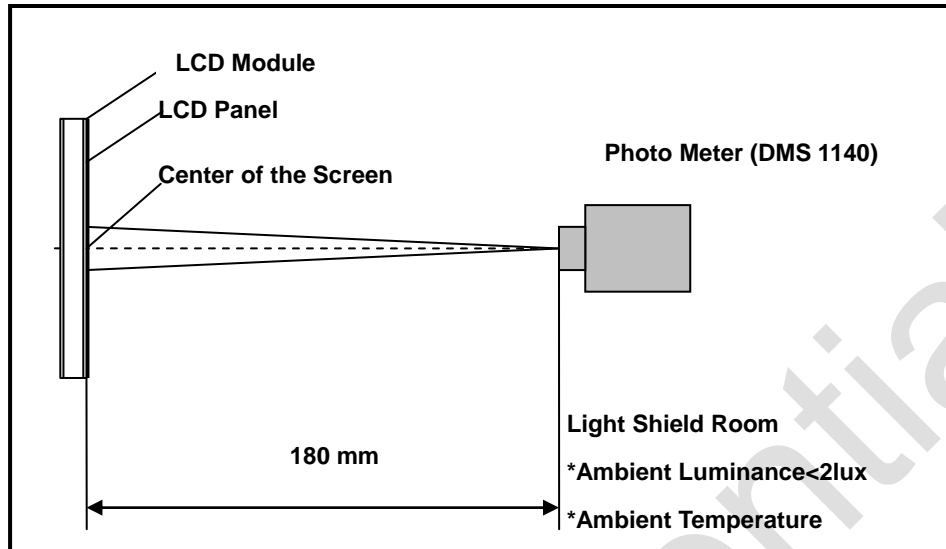

Note (2) The LED input parameter setting as:

I_LED: 12V;

PWM_LED: Duty 100 %

Note (3) Definition of Viewing Angle

Figure 4 Definition of Viewing Angle

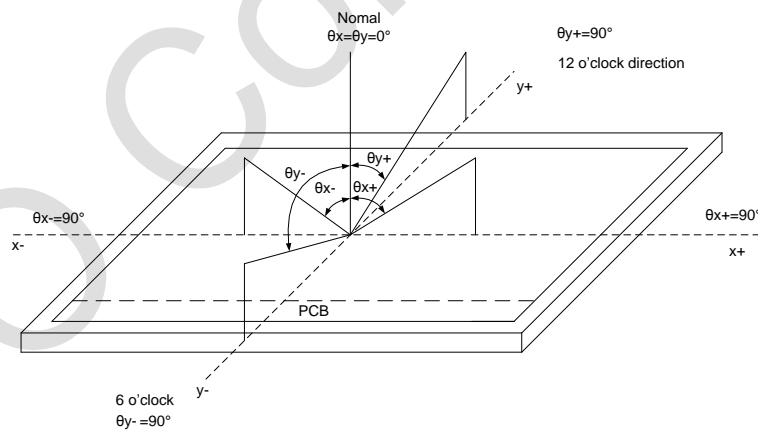

Document Title	M070SWP1 R5 Customer Approved Specification	Page No.	9/24
Document No.		Issue date	2016/01/04
		Revision	00

Note (4) Definition Of Contrast Ratio (CR)

The contrast ratio can be calculated by the following expression:

$$\text{Contrast Ratio (CR)} = L_{255} / L_0$$

L255: Luminance of gray level 255, L0: Luminance of gray level 0

Note (5) Definition Of Response Time (T_R , T_F)

Figure 5 Definition of Response Time

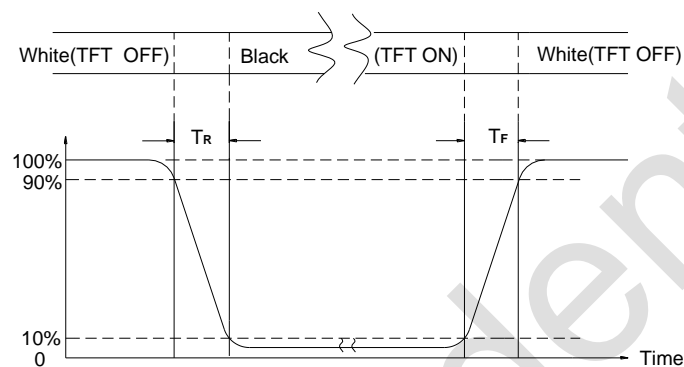

Note (6) Definition Of Luminance White

Measure the luminance of gray level 255 (Ref.: Active Area)

$$\text{Display Luminance} = (L_1 + L_2 + L_3 + \dots + L_9) / 9$$

H—Active Area Width, V—Active Area Height, L—Luminance

Note (7) Definition Of Luminance Uniformity (Ref.: Active Area)

Measure the luminance of gray level 255 at 9 points.

$$\text{Luminance Uniformity} = \text{Min.}(L_1, L_2, \dots, L_9) / \text{Max.}(L_1, L_2, \dots, L_9)$$

H—Active Area Width, V—Active Area Height, L—Luminance

Document Title	M070SWP1 R5 Customer Approved Specification		Page No.	10/24	
Document No.		Issue date	2016/01/04	Revision	00

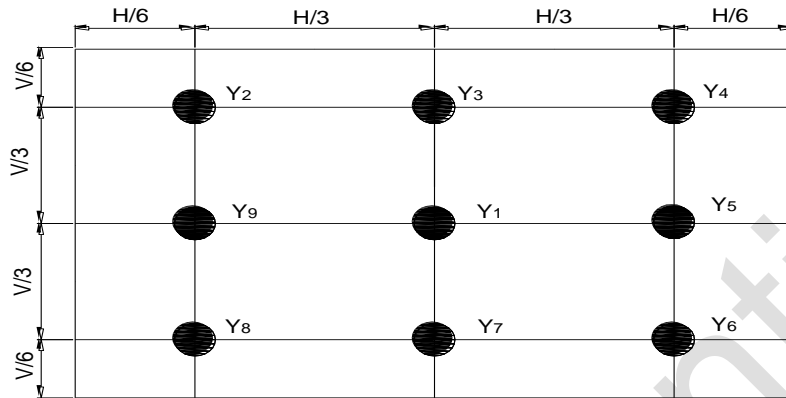
Figure 6 Measurement Locations of 9 Points



Document Title	M070SWP1 R5 Customer Approved Specification	Page No.	11/24		
Document No.		Issue date	2016/01/04	Revision	00

4.0 Electrical Characteristics

4.1 Interface Connector

Table 3 Signal Connector Type

Item	Description
Type/Part Number	089H50-000000-G2-R

Table 4 Signal Connector Pin Assignment

Pin #	Signal Name	Description	Remarks
1	GND	Ground	-
2	GND	Ground	-
3	VDD	Power Supply	3.3V(Typical)
4	VDD	Power Supply	3.3V(Typical)
5	UPDN	Gate up or down scan control	-
6	SHLR	Source right or left sequence control	-
7	GND	Ground	-
8	R0	Data Input (LSB)	-
9	R1	Data Input	-
10	R2	Data Input	-
11	R3	Data Input	-
12	GND	Ground	-
13	R4	Data Input	-
14	R5	Data Input	-
15	GND	Ground	-
16	R6	Data Input	-
17	R7	Data Input (MSB)	-
18	GND	Ground	--
19	G0	Data Input (LSB)	-
20	G1	Data Input	-
21	G2	Data Input	-
22	G3	Data Input	-
23	GND	Ground	-
24	G4	Data Input	-
25	G5	Data Input	-
26	GND	Ground	-
27	G6	Data Input	-



InfoVision Optoelectronics (Kunshan)Co., Ltd.

Document Title	M070SWP1 R5 Customer Approved Specification			Page No.	12/24
Document No.		Issue date	2016/01/04	Revision	00

28	G7	Data Input (MSB)	-
29	GND	Ground	-
30	B0	Data Input (LSB)	-
31	B1	Data Input	-
32	B2	Data Input	-
33	B3	Data Input	-
34	GND	Ground	-
35	B4	Data Input	-
36	B5	Data Input	-
37	GND	Ground	-
38	B6	Data Input	-
39	B7	Data Input (MSB)	-
40	GND	Ground	-
41	DCLK	Clock Input	-
42	GND	Ground	-
43	DE	Data Input Enable	-
44	BIST	Aging Mode	High Enable
45	GND	Ground	-
46	GND	Ground	-
47	LED_PWM	System PWM Signal Input	High Enable
48	LED_EN	LED Enable Pin	High Enable
49	VLED	LED Power Supply	-
50	VLED	LED Power Supply	-



Document Title	M070SWP1 R5 Customer Approved Specification			Page No.	13/24
Document No.		Issue date	2016/01/04	Revision	00

4.2 Interface Timings

4.2.1 Timing Characteristics

Synchronization method should be DE mode.

Table 5 Interface Timings

Parameter	Symbol	Min	Typ	Max	Unit	Note
DCLK Frequency	fclk	28	30	40	MHz	-
Horizontal Display Area	thd	800			DCLK	-
One Horizontal Line	th	908	928	1080	DCLK	-
H Blank Area	th-blank	108	128	280	DCLK	-
Vertical Display Area	tvd	480			H	-
V Period time	tv	517	525	704	H	-
V Blank Area	tv-blank	37	45	224	H	-

Note: H Blanking Time and V Blanking Time can not be changed at every frame.

Table 6 DC Electrical

(VDD=2.7 to 3.6V ,TA=-20 to +80°C)

Parameter	Symbol	Min.	Typ.	Max.	Unit	Conditions
Low level input voltage	Vil	0	-	0.3*VDD	V	For the digital circuit
High level input voltage	Vih	0.7*VDD	-	VDD	V	For the digital circuit

Document Title	M070SWP1 R5 Customer Approved Specification		Page No.	14/24	
Document No.		Issue date	2016/01/04	Revision	00

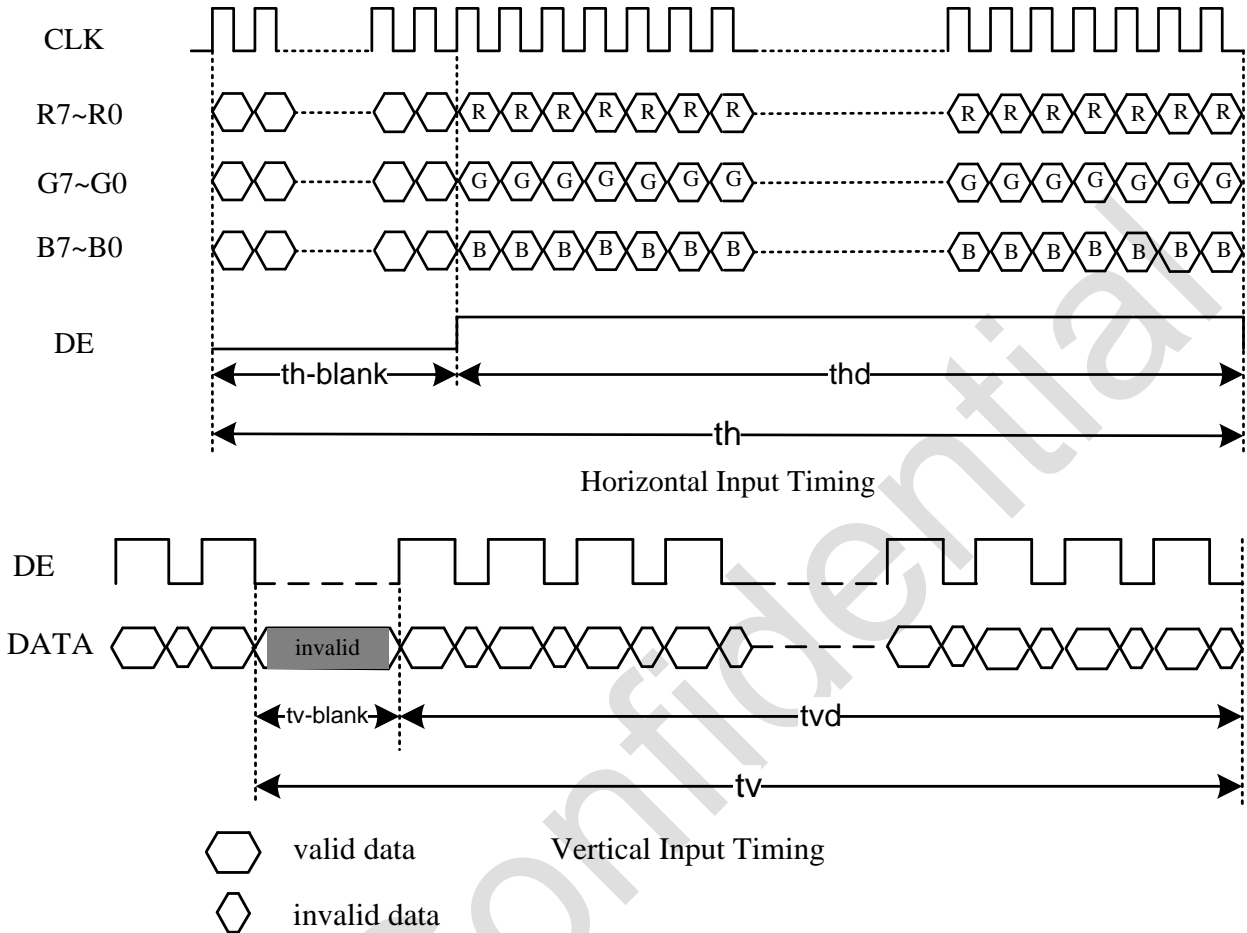
Figure 7 Timing Characteristics

Document Title	M070SWP1 R5 Customer Approved Specification			Page No.	15/24
Document No.		Issue date	2016/01/04	Revision	00

4.3 Input Power Specifications

Input power specifications are as follows.

Table 7 Input Power Specifications

Parameter	Symbol	Min.	Typ.	Max.	Unit	Note	
System Power Supply							
LCD Drive Voltage (Logic)	V_{DD}	3.0	3.3	3.6	V	(2), (4)	
VDD Current	Black Pattern	I_{DD}	-	0.1	0.15	A	(3),(4)
VDD Power Consumption	Black Pattern	P_{DD}	-	-	0.5	W	
Rush Current		I_{Rush}	-	-	1.0	A	(1),(4),(5)
Allowable Logic/LCD Drive Ripple Voltage		V_{VDD-RP}	-	-	200	mV	(4)
LED Power Supply							
LED Input Voltage	V_{LED}	4.5	12	16	V	(4)	
LED Power Consumption	P_{LED}	-	-	2.1	W	(4)	
LED Forward Voltage	V_F	2.9	3.0	3.2	V	(4)	
LED Forward Current	I_F	-	20	-	mA		
PWM Signal Voltage	High	V_{PWM}	2.5	3.3	5.5		V
	Low		-	-	0.5		
LED Enable Voltage	High	V_{LED_EN}	2.5	3.3	5.5		V
	Low		-	-	0.5		
Input PWM Frequency	F_{PWM}	100	-	1,000	Hz		
Duty Ratio	PWM	5	-	100	%		
LED Life Time	LT	20,000	30,000	-	Hours		(4)(6)

Note (1) Measure Condition

Figure 8 VDD Rising Time

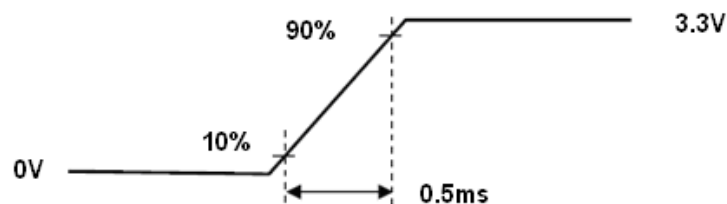

Document Title	M070SWP1 R5 Customer Approved Specification	Page No.	16/24
Document No.		Issue date	2016/01/04
		Revision	00

Note (2) VDD Power Dip Condition

$V_{TH} < V_{DD} \leq V_{min}$, $t_d \leq 10ms$ (a time of the voltage return to normal), our panel can revive automatically.

Figure 9 VDD Power Dip

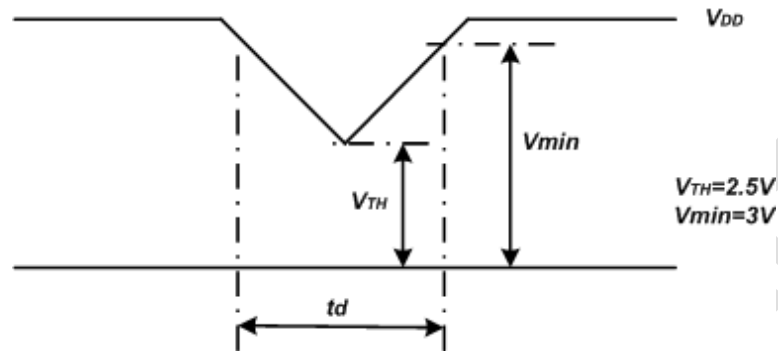

Note (3) Frame Rate=60Hz, VDD=3.3V, DC Current.

Note (4) Operating temperature 25°C, humidity 55%RH.

Note (5) The reference measurement circuit of rush current.

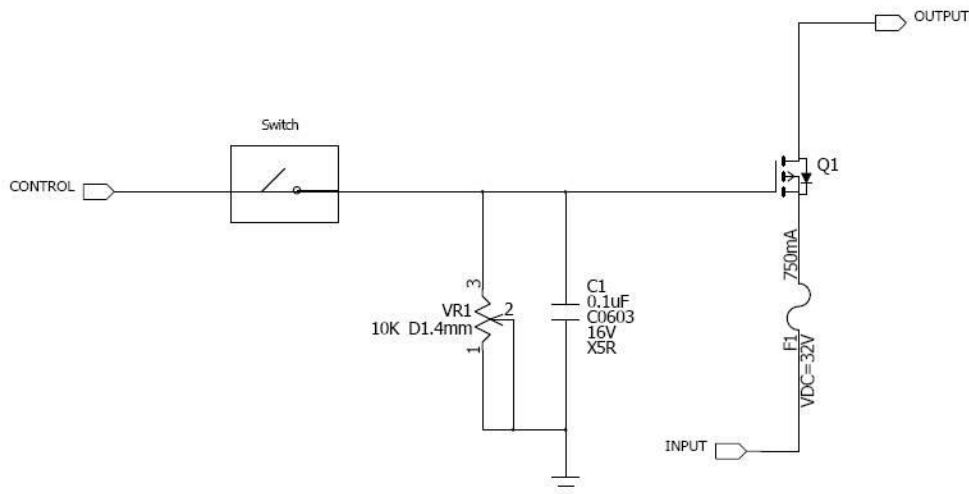

Note (6) The LED life time define as the estimated time to 50% degradation of initial luminous.

Document Title	M070SWP1 R5 Customer Approved Specification	Page No.	17/24
Document No.		Issue date	2016/01/04
		Revision	00

4.4 Power ON/OFF Sequence

Interface signals are also shown in the chart. Signals from any system shall be Hi- resistance state or low level when VDD voltage is off.

Figure 10 Power Sequence

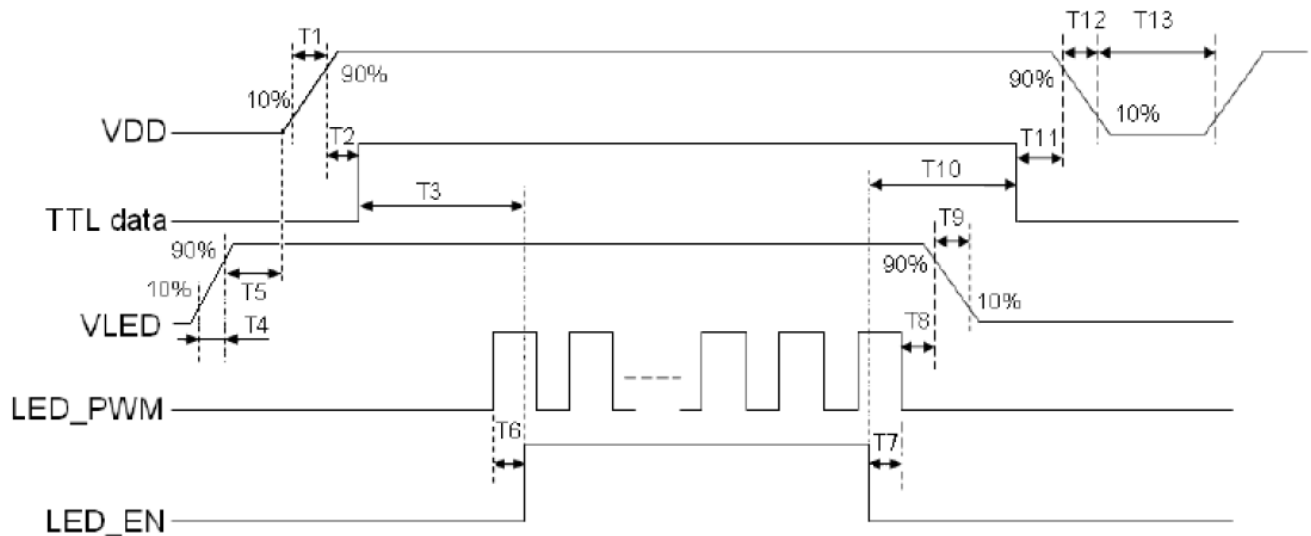

Table 8 Power Sequencing Requirements

Parameter	Symbol	Unit	Min	Typ	Max
VDD Rise Time	T1	ms	0.5	--	10
VDD Good to Signal Valid	T2	ms	30	--	90
Signal Valid to Backlight Enable On	T3	ms	200	--	--
Backlight Power On Time	T4	ms	0.5	--	10
Backlight Power Good to VDD Power On	T5	ms	10	--	--
System PWM ON to Backlight Enable On	T6	ms	10	--	--
Backlight Enable Off to System PWM Off	T7	ms	0	--	--
System PWM Off to B/L Power Disable	T8	ms	10	--	--
Backlight Power Off Time	T9	ms	--	10	30
Backlight Off to Signal Disable	T10	ms	200	--	--
Signal Disable to VDD Down	T11	ms	0	--	50
VDD Fall Time	T12	ms	1	--	30
VDD Off Time	T13	ms	500	--	--



Document Title	M070SWP1 R5 Customer Approved Specification	Page No.	18/24
Document No.		Issue date	2016/01/04
		Revision	00

5.0 Mechanical Characteristics

5.1 Outline Drawing

Figure 11 Reference Outline Drawing (Front Side)

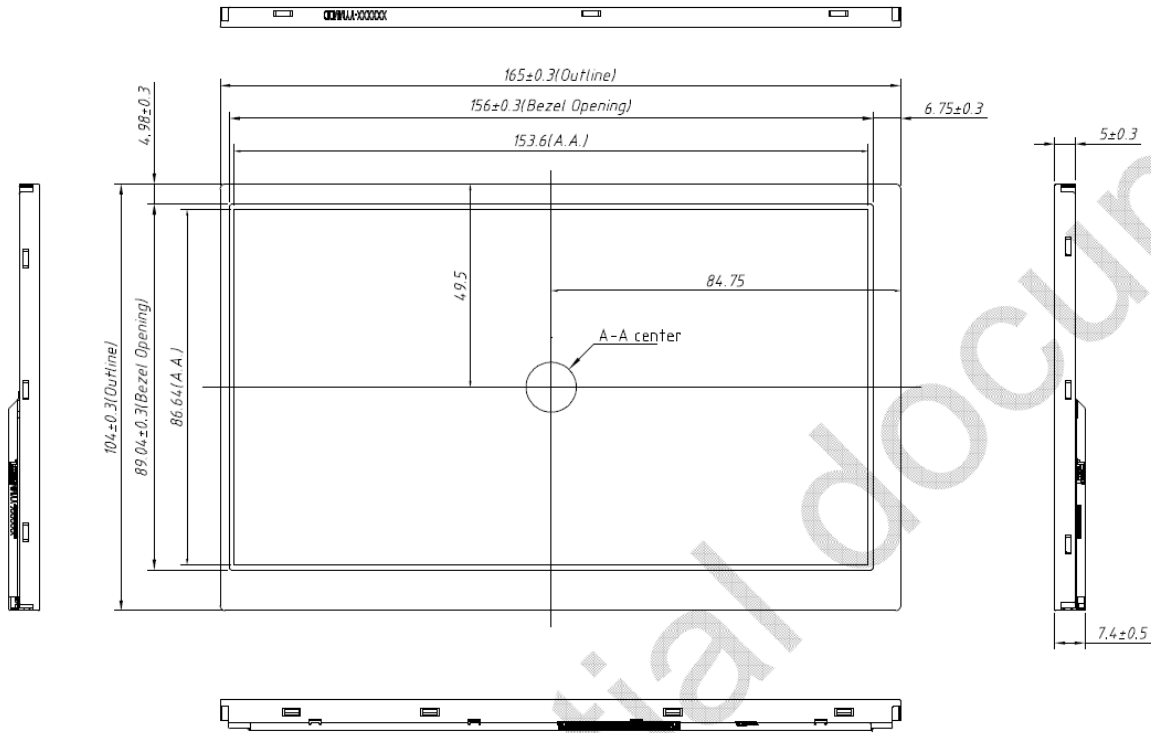
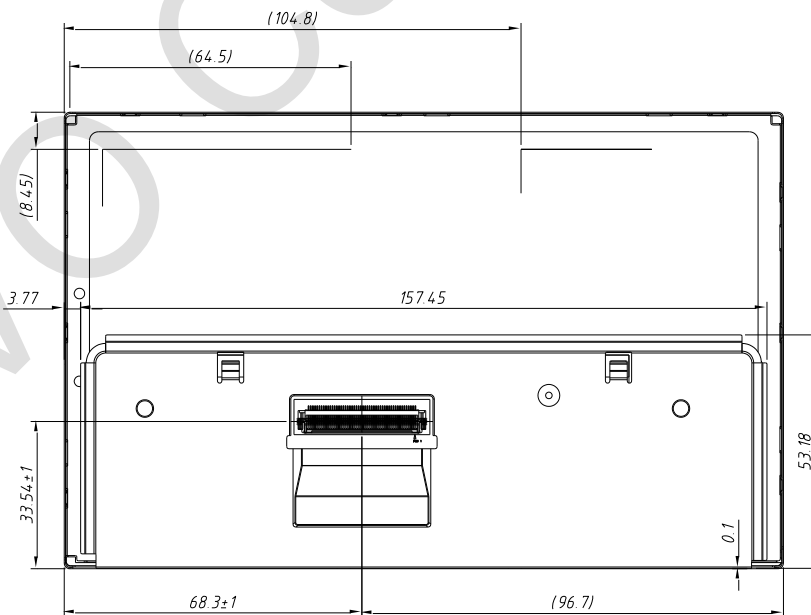

Figure 12 Reference Outline Drawing (Back Side)



Note: Unspecified tolerance to be ± 0.5

Document Title	M070SWP1 R5 Customer Approved Specification	Page No.	19/24
Document No.		Issue date	2016/01/04
		Revision	00

5.2 Active area & Bezel opening drawing

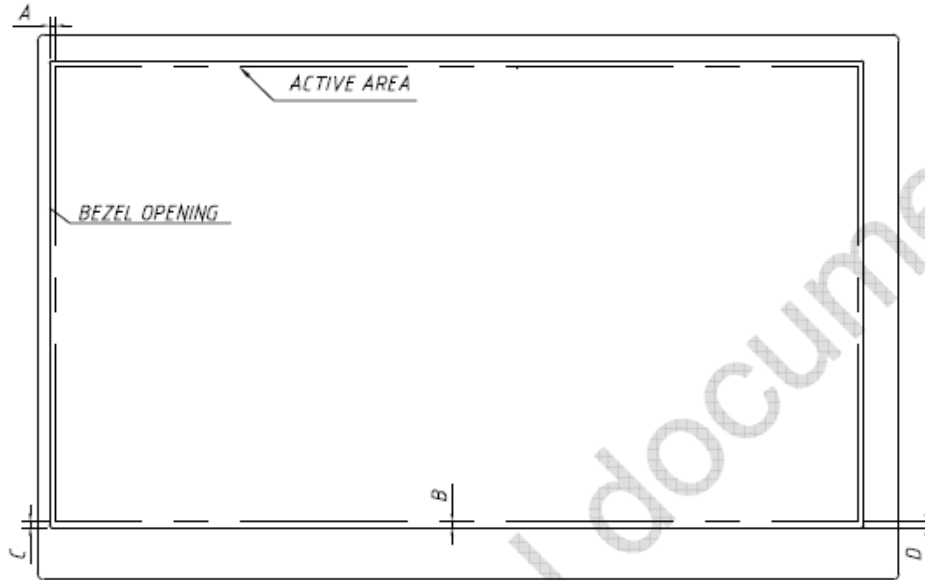

Tolerance x-direction A: $(1.2) \pm 0.5\text{mm}$

Tolerance y-direction B: $(1.2) \pm 0.5\text{mm}$

Obliquity of Display Area | C-D | $< 0.5\text{mm}$

5.3 Dimension Specifications

Table 9 Module Dimension Specifications

Width [mm]	165 ± 0.3
Height [mm]	104 ± 0.3
Thickness [mm]	7.4 ± 0.5
Weight [g]	179.5(Typ) 193.9(Max)

Figure 13 BM Area

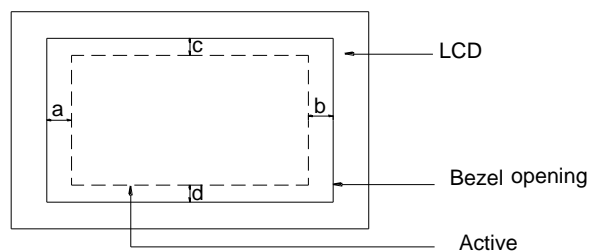



Document Title	M070SWP1 R5 Customer Approved Specification		Page No.	20/24
Document No.		Issue date	2016/01/04	Revision 00

6.0 Reliability Conditions

Item	Package	Test Conditions	Conditions
High Temperature Storage Test	Module	Ambient temperature 80°C, 500hrs	Note1
Low Temperature Storage Test	Module	Ambient temperature -30°C, 500hrs	Note1
High Temp./High Humidity Storage Test	Module	Ambient temperature 50°C, Humidity 90%, 500hrs (No condensation)	Note1
High Temperature Operation Test	Module	Ambient temperature 70°C, 500hrs	Note1
Low Temperature Operation Test	Module	Ambient temperature -20°C, 500hrs	Note1
High Temp/High Humidity Operation Test	Module	Ambient temperature 50°C, Humidity 85%, 500hrs (No condensation)	Note1
Image Sticking Test	Module	Ambient temperature 25°C, 24H	Note1
Thermal shock test	Module	-30°C ~ 80°C, 1hr/each cycle, 200cycles	Note1
ESD Test	Module	Operating Contact ± 8KV Operating Air ± 15KV	Note1
		Non-Operating Contact ± 10KV Non-Operating Air ± 20KV	Note1
Vibration Test	Module	1.5G, 10~500Hz, x, y, z each axis/1h	Note1
Shock Test	Module	Half Sine Wave 240G 2ms, ±X, ±Y, ±Z 1 times each axis	Note1
Vibration Test (no-operating)	With package	1.5G, 10~500Hz, x, y, z each axis/1h	Note1
Drop test		61cm, 1corner, 3arris, 6side	

Note1:

Under the display quality test conditions with normal operation state, these shall be no change which may affect practical display function. (normal operation state: Temperature: 15~35 °C, Humidity: 45~75%, Atmospheric pressure: 86~106kpa)



Document Title	M070SWP1 R5 Customer Approved Specification	Page No.	21/24
Document No.		Issue date	2016/01/04
		Revision	00

7.0 Package Specification

Figure 14 Packing Method

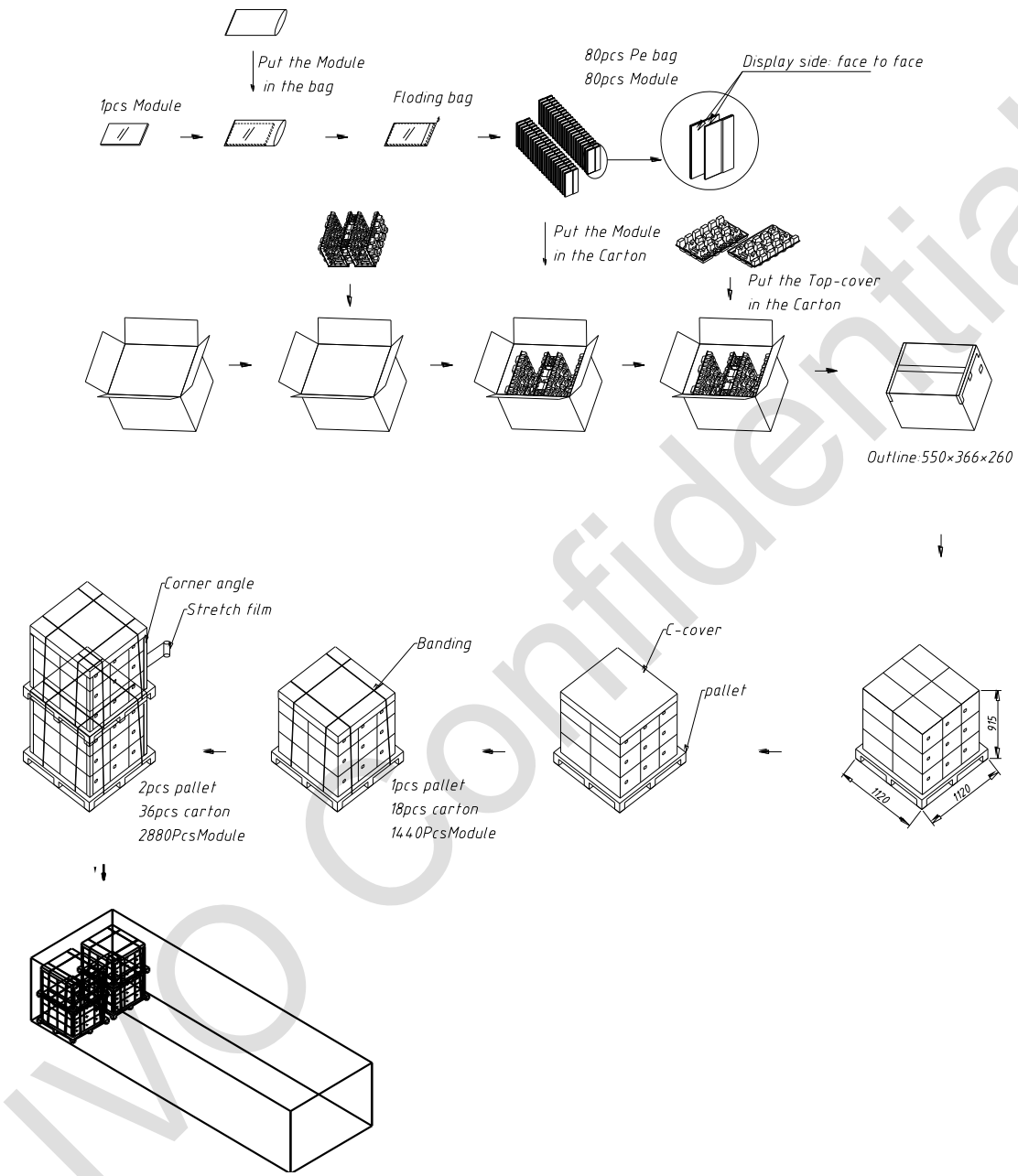

Components Material	Carton	PE Bag	Module	Protect film	Weight		
					200g/pcs module	20Kg/Carton	380Kg/Pallet
Matrrial Size(mm)	550*366*260	220*115*0.06	165*104*7.41	162*98*0.08			
Amount	1 Pcs/Carton	80Pcs/Carton	80Pcs/Carton	80Pcs/Carton		80Pcs Module (include packing)	1440Pcs Module (include packing)



Document Title	M070SWP1 R5 Customer Approved Specification			Page No.	22/24
Document No.		Issue date	2016/01/04	Revision	00

8.0 Lot Mark



Note: This picture is only an example.

8.1 20 Lot Mark

1	2	3	4	5	6	7	8	9	10	11	12	13	14	15	16	17	18	19	20
---	---	---	---	---	---	---	---	---	----	----	----	----	----	----	----	----	----	----	----

Code 1,2,4,5,6,7,8,9,10,11,16: IVO internal flow control code.
 Code 3: Production Location.
 Code 12: Production Year.
 Code 13: Production Month.
 Code 14,15: Production Day.
 Code 17,18,19,20: Serial Number.

8.2 23 Product Barcode

1	2	3	4	5	6	7	8	9	10	11	12	13	14	15	16	17	18	19	20	21	22	23
---	---	---	---	---	---	---	---	---	----	----	----	----	----	----	----	----	----	----	----	----	----	----

Code 1,2: Manufacture District.
 Code 3,4,5,6,7: IVO internal module name.
 Code 8,9,10,13,16: IVO internal flow control code.
 Code 11,12: Cell location Suzhou, China defined as "KS".
 Code 14,15: Module location Kunshan, China defined as "KS"; Yangzhou, China defined as "YZ"; Shenzhen, China defined as "SE"; Zhuhai, China defined as "ZH"; Suzhou, China defined as "SZ".
 Code 17,18,19 : Year, Month, Day refer to Note(1), Note(2) and Note(3).

Note (1) Production Year

Year	2006	2007	2008	2009	2010	2011	2012	2013	2035
Mark	6	7	8	9	A	B	C	D	Z

Note (2) Production Month

Month	Jan.	Feb.	Mar.	Apr.	May.	Jun.	Jul.	Aug.	Sep.	Oct	Nov.	Dec.
Mark	1	2	3	4	5	6	7	8	9	A	B	C

Note (3) Production Day: 1~V.

Code 20~23 : Serial Number.



Document Title	M070SWP1 R5 Customer Approved Specification		Page No.	23/24	
Document No.		Issue date	2016/01/04	Revision	00

9.0 General Precaution

9.1 Use Restriction

This product is not authorized for use in life supporting systems, aircraft navigation control systems, military systems and any other application where performance failure could be life-threatening or otherwise catastrophic.

9.2 Handling Precaution

- (1) Please mount LCD module by using mounting holes arranged in four corners tightly.
- (2) Do not disassemble or modify the module. It may damage sensitive parts inside LCD module, and may cause scratches or dust on the display. IVO does not warrant the module, if customers disassemble or modify the module.
- (3) If LCD panel is broken and liquid crystal spills out, do not ingest or inhale liquid crystal, and do not contact liquid crystal with skin. If liquid crystal contacts mouth or eyes, rinse out with water immediately. If liquid crystal contacts skin or cloths, wash it off immediately with alcohol and rinse thoroughly with water.
- (4) Disconnect power supply before handling LCD module.
- (5) Refrain from strong mechanical shock and /or any force to the module.
- (6) Do not exceed the absolute maximum rating values, such as the supply voltage variation, input voltage variation, variation in parts parameters, environmental temperature; etc otherwise LCD module may be damaged. It's recommended employing protection circuit for power supply.
- (7) Do not touch, push or rub the polarizer with anything harder than HB pencil lead. Use fingerstalls of soft gloves in order to keep clean display quality, when persons handle the LCD module for incoming inspection or assembly.
- (8) When the surface is dusty, please wipe gently with absorbent cotton or other soft material. When cleaning the adhesives, please use absorbent cotton wetted with a little petroleum benzene or other adequate solvent.
- (9) Wipe off saliva or water drops as soon as possible. If saliva or water drops contact with polarizer for a long time, they may causes deformation or color fading.
- (10) Protection film must remove very slowly from the surface of LCD module to prevent from electrostatic occurrence.
- (11) Because LCD module uses CMOS-IC on circuit board and TFT-LCD panel, it is very weak to electrostatic discharge, please be careful with electrostatic discharge. Persons who handle the module should be grounded through adequate methods.
- (12) Do not adjust the variable resistor located on the module.

9.3 Storage Precaution

- (1) Please do not leave LCD module in the environment of high humidity and high temperature for a long time.
- (2) The module shall not be exposed under strong light such as direct sunlight. Otherwise, display characteristics may be changed.
- (3) The module should be stored in a dark place. It is prohibited to apply sunlight or fluorescent light in storage.

9.4 Operation Precaution

- (1) Do not connect or disconnect the module in the "Power On" condition.
- (2) Power supply should always be turned on/off by "Power On/Off Sequence".
- (3) Module has high frequency circuits. Sufficient suppression to the electromagnetic interference should be done by system manufacturers. Grounding and shielding



Document Title	M070SWP1 R5 Customer Approved Specification		Page No.	24/24	
Document No.		Issue date	2016/01/04	Revision	00

methods may be important to minimize the interference.

- (4) After installation of the TFT module into an enclosure, do not twist nor bend the TFT module even momentary. At designing the enclosure, it should be taken into consideration that no bending/twisting forces are applied to the TFT module from outside. Otherwise the TFT module may be damaged.

9.5 Others

- (1) Ultra-violet ray filter is necessary for outdoor operation.
- (2) Avoid condensation of water which may result in improper operation or disconnection of electrode.
- (3) If the module keeps displaying the same pattern for a long period of time, the image may be "sticked" to the screen.
- (4) This module has its circuitry PCB's on the rear side and should be handled carefully in order not to be stressed.

9.6 Disposal

When disposing LCD module, obey the local environmental regulations.