



Document Name	M125NWF4 R0 Customer Approval Specification			Page 1 of 32	
Document No.	A-M125NWF4-R0-480-02	Made/Revised Date	2018/11/16	Ver.	03

Customer Approval Specification

To:

Product Name: M125NWF4 R0

Document Issue Date: 2018/11/16

Customer	InfoVision Optoelectronics
<p style="text-align: center;"><u>SIGNATURE</u></p> <p style="text-align: center;">_____</p> <p style="text-align: center;">_____</p> <p style="text-align: center;">_____</p> <p>Please return 1 copy for your confirmation with your signature and comments.</p>	<p style="text-align: center;"><u>SIGNATURE</u></p> <p style="text-align: center;">REVIEWED BY CQM</p> <p style="text-align: center;">_____</p> <p style="text-align: center;">PREPARED BY FAE</p> <p style="text-align: center;">_____</p>

- Note: 1. Please contact InfoVision Company. before designing your product based on this product.
2. The information contained herein is presented merely to indicate the characteristics and performance of our products. No responsibility is assumed by IVO for any intellectual property claims or other problems that may result from application based on the module described herein.

FQ-7-30-0-009-03D



InfoVision Optoelectronics (Kunshan) Co.,LTD.

Document Name	M125NWF4 R0 Customer Approval Specification			Page 2 of 32	
Document No.	A-M125NWF4-R0-480-02	Made/Revised Date	2018/11/16	Ver.	03

Revision	Date	Page	Old Description	New Description	Remark
00	2017/09/07		--	First issue.	
01	2017/10/15	14/19		Update LED Forward Voltage / Reference Outline Drawing (Back Side)	
02	2018/05/24	5		Update Functional Block Diagram	
02	2018/05/24	6		Update Table 1 note(4)	
02	2018/05/24	9		Update note(4) CR	
02	2018/05/24	9		Update note(6) Definition of Luminance White	
02	2018/05/24	10		Update note(7) Definition of Luminance Uniformity	
02	2018/05/24	13		Update Display Port note of Table6 and Table7	
02	2018/05/24	14		Update interface timings	
02	2018/05/24	17/18		Update Power ON/OFF Sequence	
02	2018/05/24	22		Update Reliability Conditions	
02	2018/05/24	24/27		Add lot mark and EDID	
02	2018/05/24	20		Update Figure 15	
02	2018/07/26	15/24		Uptate VDD power consumption and Lot Mark	
03	2018/11/16	24/27		Updated lable HW, EDID FW	
03	2019/05/19	24		Updated lable HW,	



Document Name	M125NWF4 R0 Customer Approval Specification			Page 3 of 32	
Document No.	A-M125NWF4-R0-480-02	Made/Revised Date	2018/11/16	Ver.	03

CONTENTS

1.0	GENERAL DESCRIPTIONS	4
2.0	ABSOLUTE MAXIMUM RATINGS	6
3.0	OPTICAL CHARACTERISTICS.....	7
4.0	ELECTRICAL CHARACTERISTICS.....	11
5.0	MECHANICAL CHARACTERISTICS.....	18
6.0	RELIABILITY CONDITIONS	22
7.0	PACKAGE SPECIFICATION	23
8.0	LOT MARK	24
9.0	GENERAL PRECAUTION	25
10.0	EDID TABLE FORMAT.....	27



Document Name	M125NWF4 R0 Customer Approval Specification			Page 4 of 32	
Document No.	A-M125NWF4-R0-480-02	Made/Revised Date	2018/11/16	Ver.	03

1. General Descriptions

1.1 Introduction

The M125NWF4 R0 is a Color Active Matrix Liquid Crystal Display with a back light system. The matrix uses a-Si Thin Film Transistor as a switching device. This TFT LCD has a 12.5 inch diagonally measured active display area with FHD resolution (1920 horizontal by 1080 vertical pixels array).

1.2 Features

- Supported FHD Resolution
- eDP1.3 Interface
- Wide View Angle
- Compatible with RoHS Standard

1.3 Product Summary

Items	Specifications	Unit
Screen Diagonal	12.5	inch
Active Area (H x V)	276.48 x 155.52	mm
Number of Pixels (H x V)	1,920 x 1,080	-
Pixel Pitch (H x V)	0.144 x 0.144	mm
Pixel Arrangement	R.G.B. Vertical Stripe	-
Display Mode	Normally Black	-
White Luminance	300 (Typ.)	cd /m ²
Contrast Ratio	1200 (Typ.)	-
Response Time	30 (Typ.)	ms
Input Voltage	3.3 (Typ.)	V
Power Consumption	2.8 (Max.) @ Mosaic pattern,FV=60Hz VDD=3.3V	W
Weight	170 (Max.)	g
Outline Dimension (H x V x D)	Without PCBA	mm
	With PCBA	
Electrical Interface (Logic)	eDP1.3	-
Support Color	16.7M (6bit+ Hi-FRC)	-
NTSC	50 (Typ.)	%
Viewing Direction	All	-
Surface Treatment	Glare,3H	-

Document Name	M125NWF4 R0 Customer Approval Specification			Page 5 of 32	
Document No.	A-M125NWF4-R0-480-02	Made/Revised Date	2018/11/16	Ver.	03

1.4 Functional Block Diagram

Figure 1 shows the functional block diagram of the LCD module.

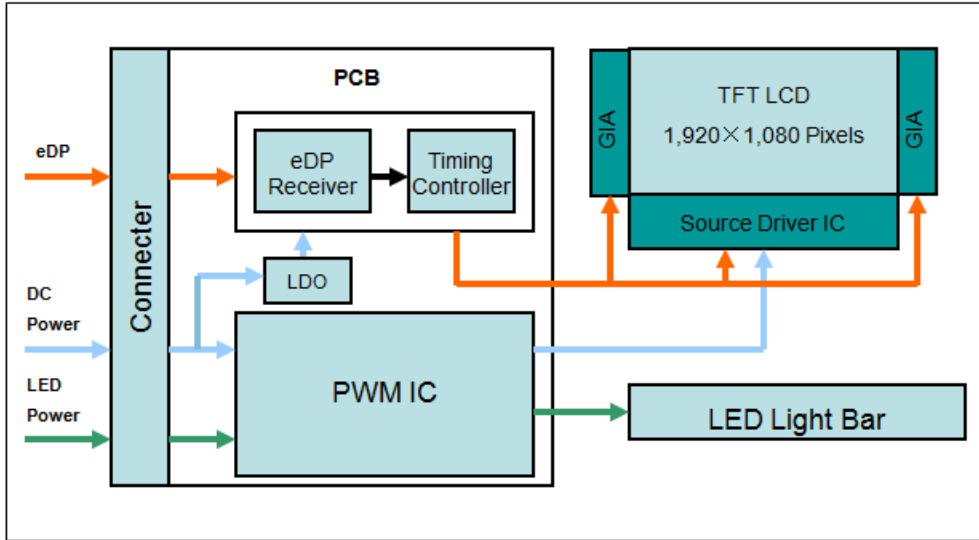

Figure 1 Block Diagram

1.5 Pixel Mapping

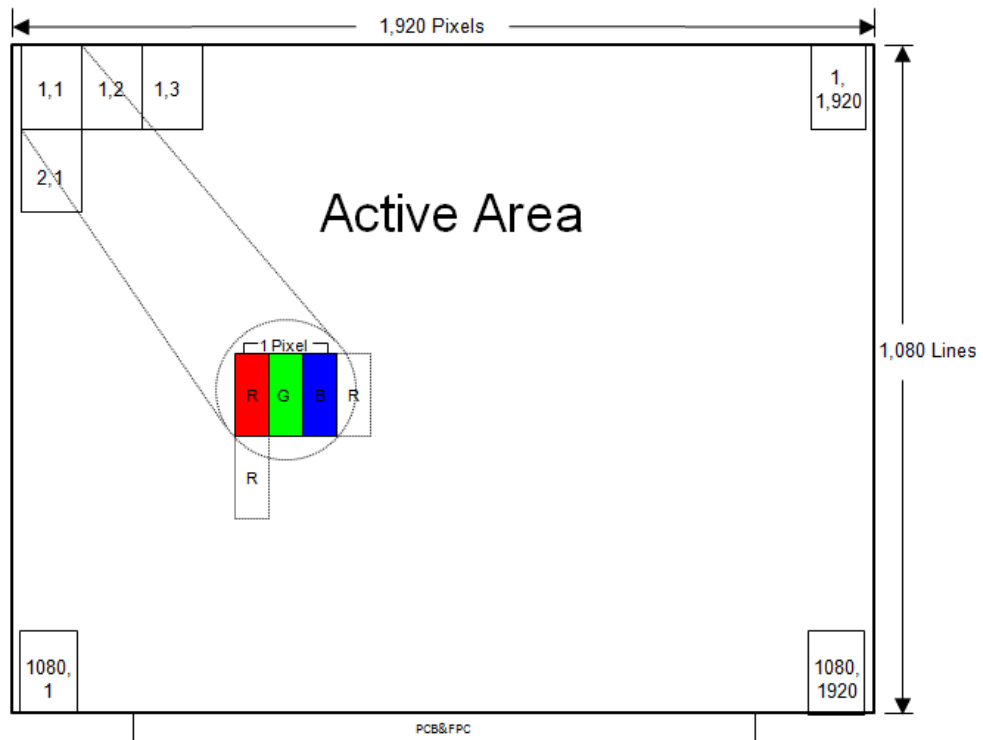

Figure2 Pixel Mapping in the Display

Document Name	M125NWF4 R0 Customer Approval Specification			Page 6 of 32	
Document No.	A-M125NWF4-R0-480-02	Made/Revised Date	2018/11/16	Ver.	03

2. Absolute Maximum Ratings

Table 1 Electrical & Environment Absolute Rating

Item	Symbol	Min.	Max.	Unit	Note
Logic Supply Voltage	V_{DD}	-0.5	3.63	V	(1),(2)
Logic Input Signal Voltage	V_{Signal}	-0.3	1.39	V	
Operating Temperature	T_{gs}	0	50	°C	(3),(4)
Storage Temperature	T_a	-20	60	°C	

Note(1) All the parameters specified in the table are absolute maximum rating values that may cause faulty operation or unrecoverable damage, if exceeded. It is recommended to follow the typical value.

Note(2) All the contents of electro-optical specifications and display fineness are guaranteed under Normal Conditions. All the display fineness should be inspected under normal conditions. Normal conditions are defined as follow: Temperature: 25°C, Humidity: 55±10%RH.

Note(3) Unpredictable results may occur when it was used in extreme conditions. T_a = Ambient Temperature, T_{gs} = Glass Surface Temperature. All the display fineness should be inspected under normal conditions.

Note(4) Temperature and relative humidity range are shown in the figure below. Wet bulb temperature should be lower than 46°C, and no condensation of water. Besides, protect the module from static electricity.

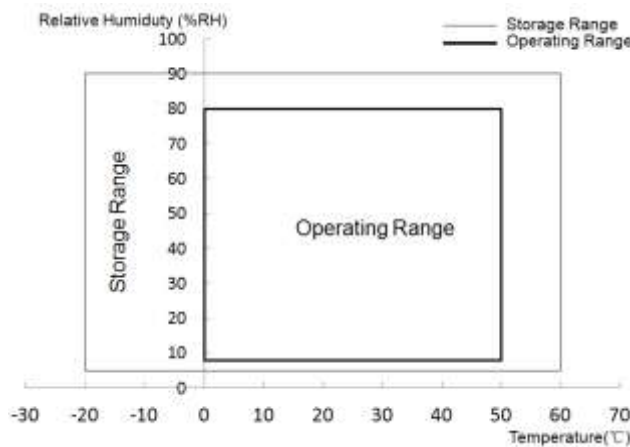

Figure 3 Absolute Ratings of Environment of the LCD Module



Document Name	M125NWF4 R0 Customer Approval Specification			Page 7 of 32	
Document No.	A-M125NWF4-R0-480-02	Made/Revised Date	2018/11/16	Ver.	03

3. Optical Characteristics

The optical characteristics are measured under stable conditions as following notes.

Table 2 Optical Characteristics

Item	Conditions	Min.	Typ.	Max.	Unit	Note
Viewing Angle (CR≥10)	Horizontal	θ_{x+}	80	85	-	degree (1),(2),(3), (4),(8)
		θ_{x-}	80	85	-	
	Vertical	θ_{y+}	80	85	-	
		θ_{y-}	80	85	-	
Contrast Ratio	Center	960	1200	-	-	(1),(2),(4),(8) $\theta_x=\theta_y=0^\circ$
Response Time	Rising + Falling	-	30	35	ms	(1),(2),(5),(8) $\theta_x=\theta_y=0^\circ$
Color Chromaticity (CIE1931)	Red x	Typ. -0.03	0.586	Typ. +0.03	-	(1),(2),(3),(8) $\theta_x=\theta_y=0^\circ$
	Red y		0.355		-	
	Green x		0.312		-	
	Green y		0.554		-	
	Blue x		0.153		-	
	Blue y		0.083		-	
	White x		0.313		-	
	White y		0.329		-	
NTSC	-	47	50	-	%	(1),(2),(3),(8) $\theta_x=\theta_y=0^\circ$
White Luminance	5 Points Average	255	300	375	cd/m ²	(1),(2),(6),(8) $\theta_x=\theta_y=0^\circ$
Luminance Uniformity	5 Points	80	-	-	%	(1),(2) (7),(8) $\theta_x=\theta_y=0^\circ$
	13 Points	60	-	-		

Document Name	M125NWF4 R0 Customer Approval Specification			Page 8 of 32	
Document No.	A-M125NWF4-R0-480-02	Made/Revised Date	2018/11/16	Ver.	03

Note(1) Measurement Setup:

The LCD module should be stabilized at given ambient temperature (25°C) for 30 minutes to avoid abrupt temperature changing during measuring. In order to stabilize the luminance, the measurement should be executed after lighting backlight for 30 minutes in the windless room.

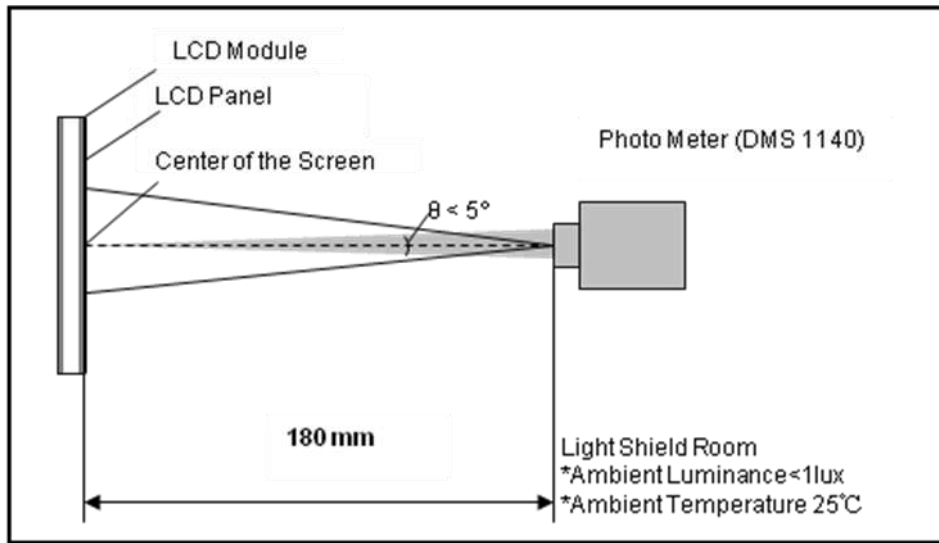

Figure 4 Measurement Setup

Note(2) The LED input parameter setting as:

V_LED:12V

PWM_LED: Duty 100 %

Note(3) Definition of Viewing Angle

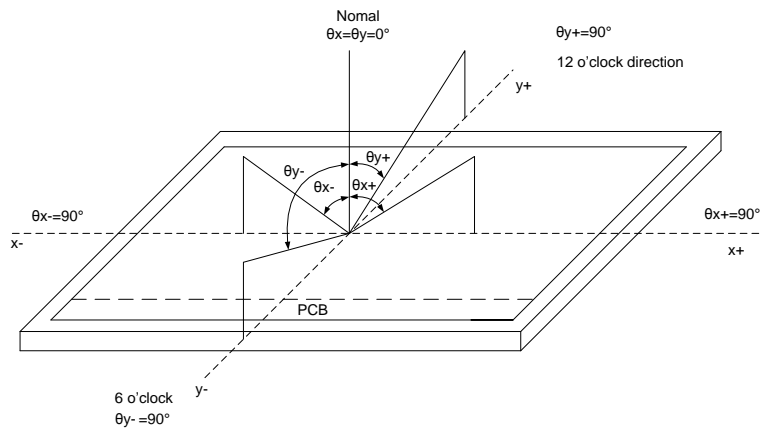

Figure 5 Definition of Viewing Angle

Document Name	M125NWF4 R0 Customer Approval Specification			Page 9 of 32	
Document No.	A-M125NWF4-R0-480-02	Made/Revised Date	2018/11/16	Ver.	03

Note(4) Definition of Contrast Ratio (CR)

The contrast ratio can be calculated by the following expression:

Contrast Ratio (CR) = The luminance of White pattern/ The luminance of Black pattern

Note(5) Definition of Response Time (T_R , T_F)

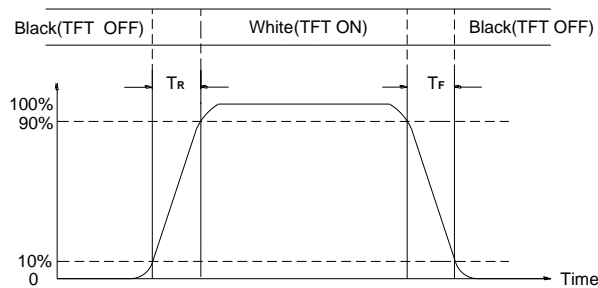

Figure 6 Definition of Response Time

Note(6) Definition of Luminance White

Measure the luminance of White pattern (Ref.: Active Area)

Display Luminance= $(L1+L2+L3+L4+L5) / 5$

H—Active Area Width, V—Active Area Height, L—Luminance

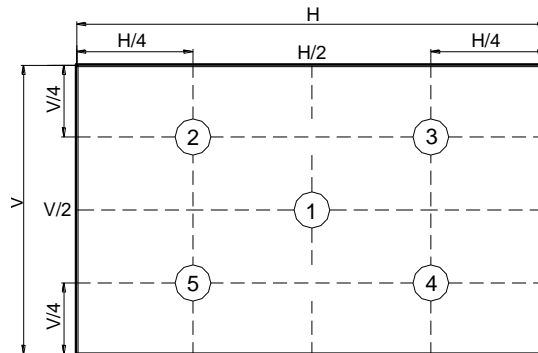

Figure 7 Measurement Locations of 5 Points

Document Name	M125NWF4 R0 Customer Approval Specification			Page 10 of 32	
Document No.	A-M125NWF4-R0-480-02	Made/Revised Date	2018/11/16	Ver.	03

Note(7) Definition of Luminance Uniformity (Ref.: Active Area)

Measure the luminance of White pattern at 5 points.

Luminance Uniformity= $\text{Min.}(L1, L2, \dots L5) / \text{Max.}(L1, L2, \dots L5)$

Measure the luminance of White pattern at 13 points.

Luminance Uniformity= $\text{Min.}(L1, L2, \dots L13) / \text{Max.}(L1, L2, \dots L13)$

H—Active Area Length, V—Active Area Width, L—Luminance

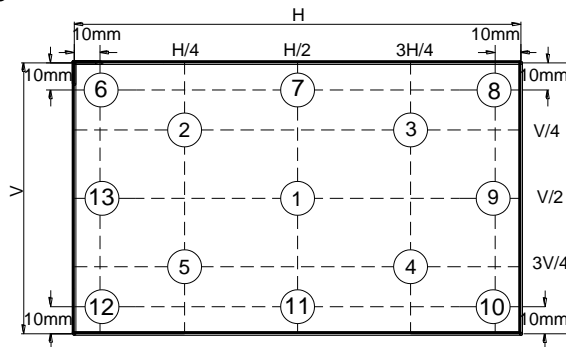

Figure 8 Measurement Locations of 13 Points

Note(8) All optical data based on IVO given system & nominal parameter & testing machine in this document.



Document Name	M125NWF4 R0 Customer Approval Specification			Page 11 of 32	
Document No.	A-M125NWF4-R0-480-02	Made/Revised Date	2018/11/16	Ver.	03

4. Electrical Characteristics

4.1 Interface Connector

Table 3 Signal Connector Type

Item	Description
Manufacturer / Type	Ipex/ 20455-030E-66
Mating Receptacle / Type (Reference)	Ipex/20454-230T

Table 4 Signal Connector Pin Assignment

Pin	Signal Name	Description	Remarks
1	NC	No Connection	-
2	H_GND	High Speed Ground	-
3	LAN1_N	Complement Signal Link Lane 1	-
4	LAN1_P	True Signal Link Lane 1	-
5	H_GND	High Speed Ground	-
6	LAN0_N	Complement Signal Link Lane 0	-
7	LAN0_P	True Signal Link Lane 0	-
8	H_GND	High Speed Ground	-
9	AUX_CH_P	True Signal Auxiliary Channel	-
10	AUX_CH_N	Complement Signal Auxiliary Channel	-
11	H_GND	High Speed Ground	-
12	LCD_VCC	LCD logic and driver power	+3.3V
13	LCD_VCC	LCD logic and driver power	+3.3V
14	BIST	LCD Panel Self Test Enable, When it is not used,Connecting to GND is recommended, don't floating	-
15	LCD_GND	LCD logic and driver ground	-
16	LCD_GND	LCD logic and driver ground	-
17	HPD	HPD signal pin	-
18	BL_GND	Backlight ground	-
19	BL_GND	Backlight ground	-
20	BL_GND	Backlight ground	-
21	BL_GND	Backlight ground	-
22	BL_ENABLE	Backlight On/Off	-
23	BL_PWM	System PWM signal input	-
24	NC	No Connection	-
25	NC	No Connection	-
26	BL_PWR	Backlight power	-



Document Name	M125NWF4 R0 Customer Approval Specification			Page 12 of 32	
Document No.	A-M125NWF4-R0-480-02	Made/Revised Date	2018/11/16	Ver.	03

27	BL_PWR	Backlight power	
28	BL_PWR	Backlight power	-
29	BL_PWR	Backlight power	-
30	NC	No Connection	-

Document Name	M125NWF4 R0 Customer Approval Specification			Page 13 of 32	
Document No.	A-M125NWF4-R0-480-02	Made/Revised Date	2018/11/16	Ver.	03

4.2 Signal Electrical Characteristics

Table 5 Display Port Main Link

Parameter	Description	Min.	Typ.	Max.	Unit
V_{CM}	Differentia Common Mode Voltage	0	-	2.0	V
$V_{Diff P-P}$ Level 1	Differential Peak to Peak Voltage Level 1	0.34	0.40	0.46	V
$V_{Diff P-P}$ Level 2	Differential Peak to Peak Voltage Level 2	0.51	0.60	0.68	V
$V_{Diff P-P}$ Level 3	Differential Peak to Peak Voltage Level 3	0.69	0.80	0.92	V
$V_{Diff P-P}$ Level 4	Differential Peak to Peak Voltage Level 4	1.02	1.20	1.38	V

Note: (1) Input signals shall be low or Hi- resistance state when VDD is off.

(2) It is recommended to refer the specifications of VESA Display Port Standard

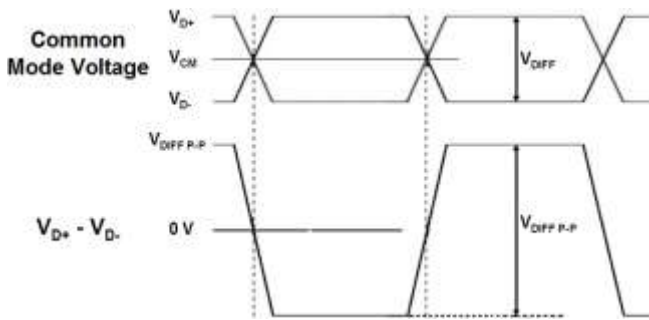

Figure 9 Display Port Main Link Signal

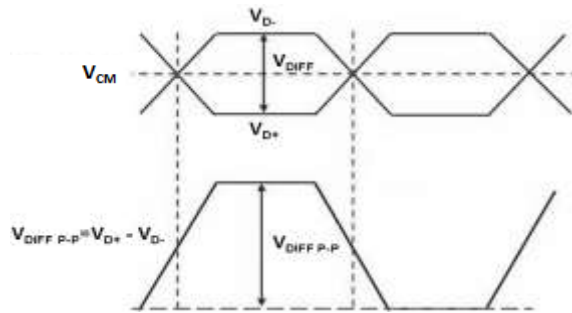

Figure 10 Display Port AUX_CH Signal

Table 6 Display Port AUX_CH

Parameter	Description	Min.	Typ.	Max.	Unit
V_{CM}	Differentia Common Mode Voltage	0	VDD/2	2	V
$V_{Diff P-P}$	Differential Peak to Peak Voltage	0.39	-	1.38	V

Note: Follow as VESA display port standard.

Table 7 Display Port V_{HPD}

Parameter	Description	Min.	Typ.	Max.	Unit
V_{HPD}	HPD Voltage	2.25	-	3.60	V

Note: Follow as VESA display port standard.



Document Name	M125NWF4 R0 Customer Approval Specification			Page 14 of 32	
Document No.	A-M125NWF4-R0-480-02	Made/Revised Date	2018/11/16	Ver.	03

4.3 Interface Timings

Table 8 Interface Timings

Parameter	Symbol	Min.	Typ.	Max.	Unit
eDP Clock Frequency	FCLK	108.2	139.03	154.3	MHz
Horizontal Total Time	THP	2040	2080	2120	clocks
Horizontal Active Time	HA	--	1920	--	clocks
Vertical Total Time	TVP	1104	1114	1120	lines
Vertical Active Time	VA	--	1080	--	lines
Frame Rate	FV	48	60	65	Hz

Note(1) $HT * VT * \text{Frame Rate} \leq 154.3\text{MHz}$

Note(2) All reliabilities are specified for timing specification based on refresh rate of 60Hz. However, IVO M125NWF4 R0 has a good actual performance even at lower refresh rate (e.g. 48Hz) for power saving mode, whereas IVO M125NWF4 R0 is secured only for function under lower refresh rate. 60Hz at Normal mode, 48Hz at Power save mode. Don't care Flicker level (power save mode).

Document Name	M125NWF4 R0 Customer Approval Specification			Page 15 of 32	
Document No.	A-M125NWF4-R0-480-02	Made/Revised Date	2018/11/16	Ver.	03

4.4 Input Power Specifications

Input power specifications are as follows.

Table 9 Input Power Specifications

Parameter	Symbol	Min.	Typ.	Max.	Unit	Note	
<i>System Power Supply</i>							
LCD Drive Voltage (Logic)	V _{DD}	3.0	3.3	3.6	V	(1), (2)	
VDD Current	Mosaic Pattern	I _{DD}	-	287	303	mA	(1),(4)
VDD Power Consumption	Mosaic Pattern	P _{DD}	-	0.95	1.0	W	
LCD Self Test (BIST)	VIH	V _{BIST}	3.0	-	3.6	V	(1)
	VIL		0	-	0.5	V	
Rush Current	I _{Rush}	-	-	2.0	A	(1),(5)	
Allowable Logic/LCD Drive Ripple Voltage	V _{VDD-RP}	-	-	200	mV	(1),(3)	
<i>LED Power Supply</i>							
LED Input Voltage	V _{LED}	5	12	21	V	(1),(2)	
LED Power Consumption	P _{LED}	-	-	1.8	W	(1),(5)	
LED Forward Voltage	V _F	-	-	3.0	V	(1),(2)	
LED Forward Current	I _F	-	19	-	mA		
PWM Signal Voltage	High	V _{PWM}	2.2	-	3.6		V
	Low		0	-	0.6		
LED Enable Voltage	High	V _{LED_EN}	2.2	-	3.6		V
	Low		0	-	0.6		
Input PWM Frequency	F _{PWM}	100	-	1,000	Hz	(1),(2),(7)	
Duty Ratio	PWM	1	-	100	%	(1),(8)	
LED Life Time	LT	15,000	-	-	Hours	(1),(9)	

Note(1) All of the specifications are guaranteed under normal conditions. Normal conditions are defined as follow: Temperature: 25°C, Humidity: 55± 10%RH.

Note(2) All of the absolute maximum ratings specified in the table, if exceeded, may cause faulty operation or unrecoverable damage. It is recommended to follow the typical value.

Note(3) VDD Power Dip Condition

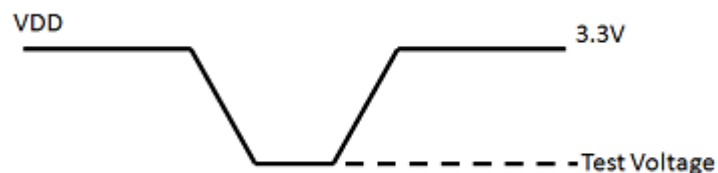

Document Name	M125NWF4 R0 Customer Approval Specification			Page 16 of 32	
Document No.	A-M125NWF4-R0-480-02	Made/Revised Date	2018/11/16	Ver.	03

Test criteria:

1) $2.4 \leq \text{Test Voltage} \leq 3.3\text{V}$: Normal operation

2) $2.0\text{V} \leq \text{Test Voltage} < 2.4\text{V}$: No abnormal display after back to 3.3V input.

Note(4) The specified V_{DD} current and power consumption are measured under the $V_{DD} = 3.3\text{V}$, $F_V = 60\text{Hz}$ condition and Mosaic Pattern

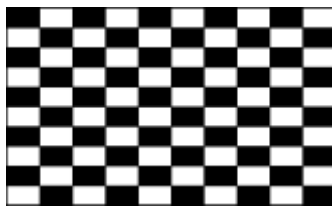

Figure 11 Mosaic Pattern

Note(5) The figure below is the measuring condition of V_{DD} . Rush current can be measured when T_{RUSH} is 0.5ms.

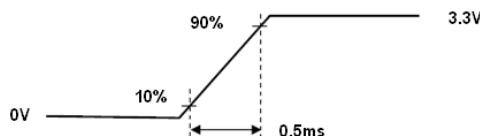

Figure 12 V_{DD} Rising Time

Note(6) The power consumption of LED Driver are under the $V_{LED} = 12.0\text{V}$, Dimming of Max luminance.

Note(7) Although acceptable range as defined, the dimming ratio is not effective at all conditions. The PWM frequency should be fixed and stable for more consistent luminance control at any specific level desired.

Note(8) The operation of LED Driver below minimum dimming ratio may cause flickering or reliability issue.

The life time is determined as the sum of the lighting time till the luminance of LCD at the typical LED current reducing to 50% of the minimum value under normal operating condition.

Document Name	M125NWF4 R0 Customer Approval Specification			Page 17 of 32	
Document No.	A-M125NWF4-R0-480-02	Made/Revised Date	2018/11/16	Ver.	03

4.5 Power ON/OFF Sequence

1. Interface signals are also shown in the chart. Signals from any system shall be Hi-resistance state or low level when VCC voltage is off.
2. When system first start up, should keep the VCC high time longer than 200ms, otherwise may cause image sticking when VCC drop off.

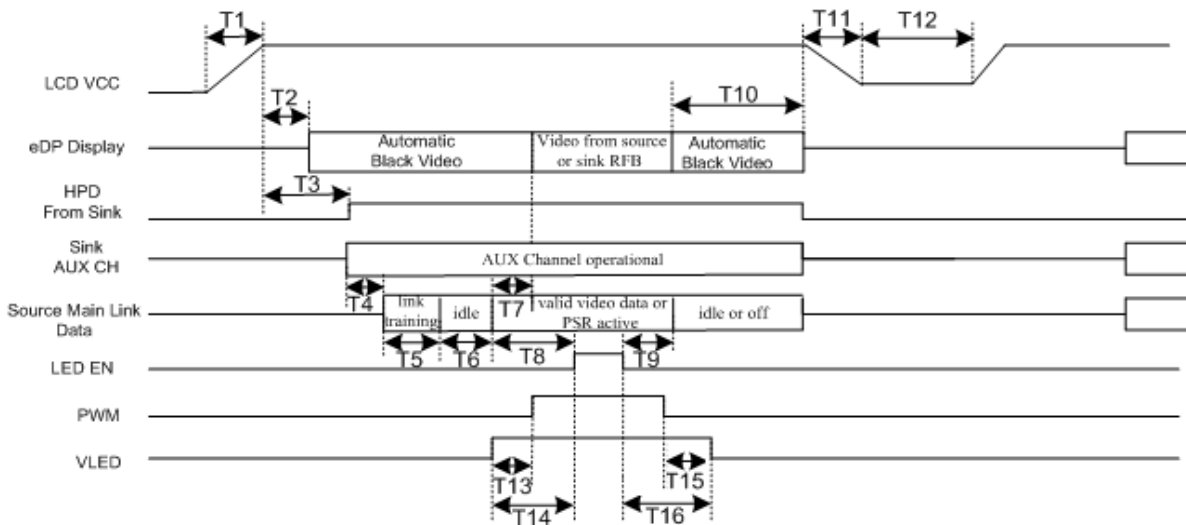

Figure 13 Power Sequence



Document Name	M125NWF4 R0 Customer Approval Specification			Page 18 of 32	
Document No.	A-M125NWF4-R0-480-02	Made/Revised Date	2018/11/16	Ver.	03

Table 10 Power Sequencing Requirements

Parameter	Symbol	Unit	Min.	Typ.	Max.
LCD_VCC Rise Time (10% to 90%)	T1	ms	0.5	-	10
Delay from LCD_VCC to automatic Black Video generation	T2	ms	0	-	200
Delay from LCD_VCC to HPD high	T3	ms	0	-	200
Delay from HPD high to link training initialization	T4	ms	-	-	-
Link training duration	T5	ms	-	-	-
Link idle	T6	ms	-	-	-
Delay from valid video data from Source to video on display	T7	ms	0	-	50
Delay from valid video data from Source to backlight enable	T8	ms	200	-	-
Delay from backlight disable to end of valid video data	T9	ms	-	-	-
Delay from end of valid video data from Source to VCC off	T10	ms	0	-	500
LCD_VCC fall time (90% to 10%)	T11	ms	0	-	10
VCC off time	T12	ms	500	-	-
Delay from VLED to PWM	T13	ms	0	-	-
Delay from VLED to backlight enable	T14	ms	0	-	-
Delay from PWM off to VLED off	T15	ms	0	-	-
Delay from backlight disable to VLED off	T16	ms	0	-	-



Document Name	M125NWF4 R0 Customer Approval Specification			Page 19 of 32	
Document No.	A-M125NWF4-R0-480-02	Made/Revised Date	2018/11/16	Ver.	03

5. Mechanical Characteristics

5.1 Outline Drawing

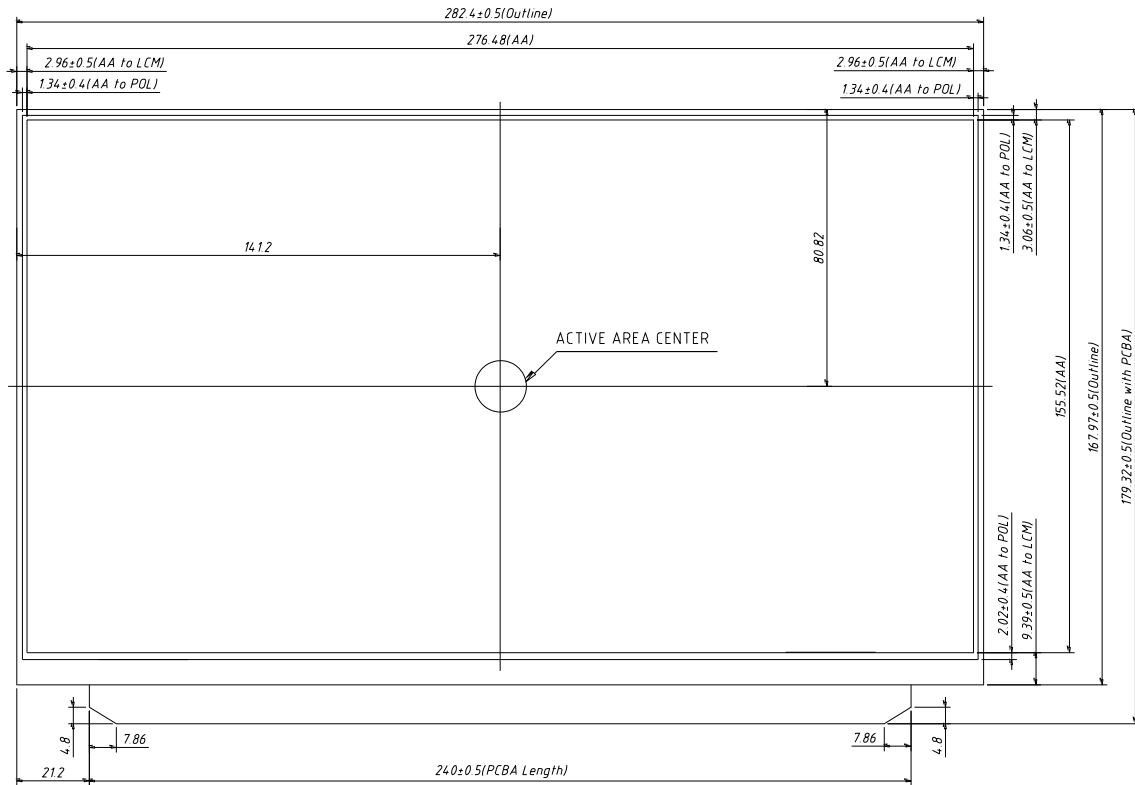

Unit: mm

Figure 14 Reference Outline Drawing (Front Side)



Document Name	M125NWF4 R0 Customer Approval Specification			Page 20 of 32	
Document No.	A-M125NWF4-R0-480-02	Made/Revised Date	2018/11/16	Ver.	03

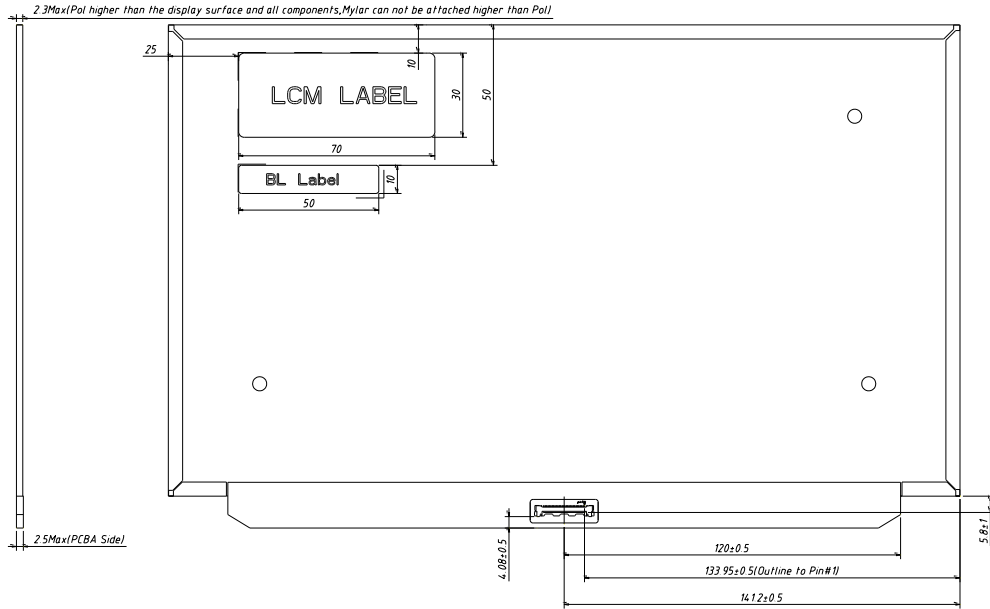

LCM Warpage Schematic

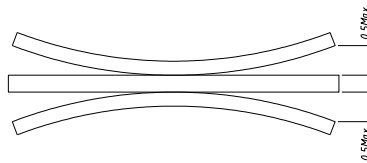

Unit: mm

Note1: Unnoted tolerance $\pm 0.5\text{mm}$;

Note2: Warpage within $\pm 0.5\text{mm}$;

Figure 15 Reference Outline Drawing (Back Side)



Document Name	M125NWF4 R0 Customer Approval Specification			Page 21 of 32	
Document No.	A-M125NWF4-R0-480-02	Made/Revised Date	2018/11/16	Ver.	03

5.2 Dimension Specifications

Table 11 Module Dimension Specifications

Item		Min.	Typ.	Max.	Unit
Height	Without PCBA	167.47	167.97	168.47	mm
	With PCBA	178.82	179.32	179.82	mm
Width		281.90	282.40	282.90	mm
Thickness	Without PCBA	-	-	2.30	mm
	With PCBA	-	-	2.50	mm
Weight		-	-	170	g

Note: Outline dimension measure instrument: Vernier caliper .



Document Name	M125NWF4 R0 Customer Approval Specification			Page 22 of 32	
Document No.	A-M125NWF4-R0-480-02	Made/Revised Date	2018/11/16	Ver.	03

6. Reliability Conditions

Table 12 Reliability Condition

Item	Package	Test Conditions		Note
High Temperature/High Humidity Operating Test	Module	$T_{gs}= 50^{\circ}\text{C}$, 80%RH, 1000 hours		(1),(2),(3), (4)
Low Temperature Operating Test	Module	$T_a=0^{\circ}\text{C}$, 500 hours		
High Temperature Storage Test	Module	$T_a=60^{\circ}\text{C}$, 240 hours		(1),(3),(4)
Low Temperature Storage Test	Module	$T_a=-20^{\circ}\text{C}$, 240 hours		
Shock Non-operating Test	Module	240G, 2ms, 1time for $\pm x, \pm y, \pm z$ 6 directions		(1),(3),(5)
Vibration Non-operating Test	Module	1.5G, 10-500Hz-10Hz, X Y Z each axis/1h		
ESD Test (Operating)	Module	Contact	$\pm 2\text{KV}(\text{Class B}) /$ $\pm 4 / \pm 6\text{KV}(\text{Class B}) /$ $\pm 8\text{KV}(\text{Class C})$	(1),(2),(6)
		Air	$\pm 4\text{KV}(\text{Class B}) /$ $\pm 8\text{KV}(\text{Class B}) /$ $\pm 12 / \pm 15\text{KV}(\text{Class C})$	

Note(1) A sample can only have one test. Outward appearance, image quality and optical data can only be checked at normal conditions according to the IVO document before reliable test. Only check the function of the module after reliability test.

Note(2) The setting of electrical parameters should follow the typical value before reliability test.

Note(3) During the test, it is unaccepted to have condensate water remains. Besides, protect the module from static electricity.

Note(4) The sample must be released for 24 hours under normal conditions before judging. Furthermore, all the judgment must be made under normal conditions. Normal conditions are defined as follow: Temperature: 25°C , Humidity: $55 \pm 10\% \text{RH}$. T_a = Ambient Temperature, T_{gs} = Glass Surface Temperature.

Note(5) The module should be fixed firmly in order to avoid twisting and bending.

Note(6) It could be regarded as pass, when the module recovers from function fault caused by ESD after resetting.

Document Name	M125NWF4 R0 Customer Approval Specification			Page 23 of 32	
Document No.	A-M125NWF4-R0-480-02	Made/Revised Date	2018/11/16	Ver.	03

7. Package Specification

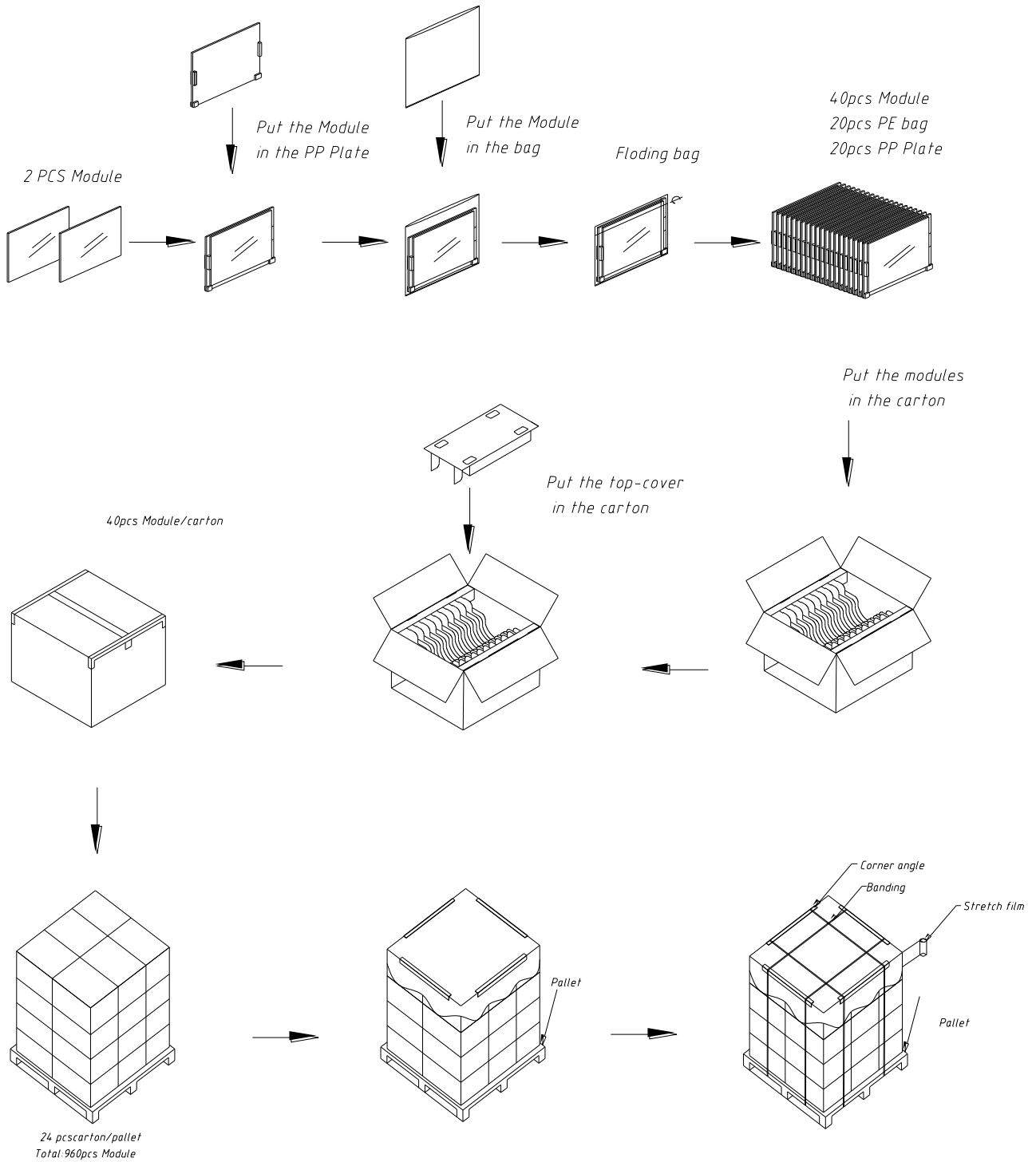
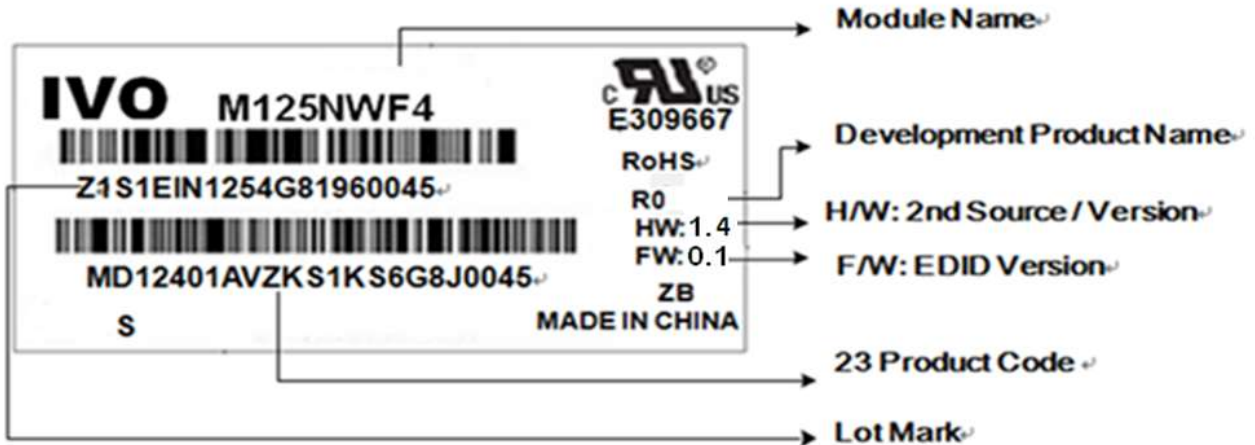

Figure 16 Packing Method



Document Name	M125NWF4 R0 Customer Approval Specification			Page 24 of 32	
Document No.	A-M125NWF4-R0-480-02	Made/Revised Date	2018/11/16	Ver.	03

8. Lot Mark



Note: This picture is only an example.

8.1 20 Lot Mark

1	2	3	4	5	6	7	8	9	10	11	12	13	14	15	16	17	18	19	20
---	---	---	---	---	---	---	---	---	----	----	----	----	----	----	----	----	----	----	----

Code 1,2,4,5,6,7,8,9,10,11,16: IVO internal flow control code.

Code 3: Production Location.

Code 12: Production Year.

Code 13: Production Month.

Code 14,15: Production Day.

Code 17,18,19,20: Serial Number.

8.2 23 Product Barcode

1	2	3	4	5	6	7	8	9	10	11	12	13	14	15	16	17	18	19	20	21	22	23
---	---	---	---	---	---	---	---	---	----	----	----	----	----	----	----	----	----	----	----	----	----	----

Code 1,2: Manufacture District.

Code 3,4,5,6,7: IVO internal module name.

Code 8,9,10,13,16: IVO internal flow control code.

Code 11,12: Cell location Suzhou, China defined as "KS".

Code 14,15: Module location Kunshan, China defined as "KS"; Yangzhou, China defined as "YZ"; Shenzhen, China defined as "SE"; Zhuhai, China defined as "ZH"; Suzhou, China defined as "SZ".

Code 17,18,19 : Year, Month, Day refer to Note(1), Note(2) and Note(3).

Note (1) Production Year

Year	2006	2007	2008	2009	2010	2011	2012	2013	2035
Mark	6	7	8	9	A	B	C	D	Z

Note (2) Production Month

Month	Jan.	Feb.	Mar.	Apr.	May.	Jun.	Jul.	Aug.	Sep.	Oct	Nov.	Dec.
Mark	1	2	3	4	5	6	7	8	9	A	B	C

Note (3) Production Day: 1~V.

Code 20~23 : Serial Number.



Document Name	M125NWF4 R0 Customer Approval Specification			Page 25 of 32	
Document No.	A-M125NWF4-R0-480-02	Made/Revised Date	2018/11/16	Ver.	03

9. General Precaution

9.1 Using Restriction

This product is not authorized for using in life supporting systems, aircraft navigation control systems, military systems and any other appliance where performance failure could be life-threatening or lead to be catastrophic.

9.2 Operation Precaution

(1)The LCD product should be operated under normal conditions.

Normal conditions are defined as below:

Temperature: 25°C

Humidity: 55±10%

Display pattern: continually changing pattern (Not stationary)

(2) Brightness and response time depend on the temperature. (It needs more time to reach normal brightness in low temperature.)

(3) It is necessary for you to pay attention to condensation when the ambient temperature drops suddenly. Condensate water would damage the polarizer and electrical contacted parts of the module. Besides, smear or spot will remain after condensate water evaporating.

(4) If the absolute maximum rating value was exceeded, it may damage the module.

(5) Do not adjust the variable resistor located on the module.

(6) Sufficient suppression to the electromagnetic interference shall be done by system manufacturers. Grounding and shielding may be important to minimize the interference.

(7) Image sticking may occur when the module displayed the same pattern for long time.

(8) Do not connect or disconnect the module in the “power on” condition. Power supply should always be turned on/off by the “power on/off sequence”

(9) Ultra-violet ray filter is necessary for outdoor operation.

9.3 Mounting Precaution

(1) All the operators should be electrically grounded and with Ion-blown equipment turning on when mounting or handling. Dressing finger-stalls out of the gloves is important for keeping the panel clean during the incoming inspection and the process of assembly.

(2) It is unacceptable that the material of cover case contains acetic or chloric. Besides, any other material that could generate corrosive gas or cause circuit break by electro-chemical reaction is not desirable.

(3) The case on which a module is mounted should have sufficient strength so that external force is not transmitted to the module directly.

(4) It is obvious that you should adopt radiation structure to satisfy the temperature specification.

(5) So as to acquire higher luminance, the cable between the back light and the inverter of the power supply should be connected directly with a minimize length.

(6) It should be attached to the system tightly by using all holes for mounting, when the module is assembled. Be careful not to apply uneven force to the module, especially to the PCB on the back.



Document Name	M125NWF4 R0 Customer Approval Specification			Page 26 of 32	
Document No.	A-M125NWF4-R0-480-02	Made/Revised Date	2018/11/16	Ver.	03

- (7) A transparent protective film needs to be attached to the surface of the module.
- (8) Do not press or scratch the polarizer exposed with anything harder than HB pencil lead. In addition, don't touch the pin exposed with bare hands directly.
- (9) Clean the polarizer gently with absorbent cotton or soft cloth when it is dirty.
- (10) Wipe off saliva or water droplet as soon as possible. Otherwise, it may cause deformation and fading of color.
- (11) Desirable cleaners are IPA (Isopropyl Alcohol) or hexane. Do not use Ketone type materials (ex. Acetone), Ethyl alcohol, Toluene, Ethyl acid or Methyl chloride. It might permanent damage to the polarizer due to chemical reaction.
- (12) Do not disassemble or modify the module. It may damage sensitive parts in the LCD module, and cause scratches or dust remains. IVO does not warrant the module, if you disassemble or modify the module.

9.4 Handling Precaution

- (1) Static electricity will generate between the film and polarizer, when the protection film is peeled off. It should be peeled off slowly and carefully by operators who are electrically grounded and with Ion-blown equipment turning on. Besides, it is recommended to peel off the film from the bonding area.
- (2) The protection film is attached to the polarizer with a small amount of glue. When the module with protection film attached is stored for a long time, a little glue may remain after peeling.
- (3) If the liquid crystal material leaks from the panel, keep it away from the eyes and mouth. In case of contact with hands, legs or clothes, it must be clean with soap thoroughly.

9.5 Storage Precaution

When storing modules as spares for long time, the following precautions must be executed.

- (1) Store them in a dark place. Do not expose to sunlight or fluorescent light. Keep the temperature between 5°C and 35°C at normal humidity.
- (2) The polarizer surface should not come in contact with any other object. It is recommended that they be stored in the container in which they were shipped.
- (3) It is recommended to use it in a short-time period, after it's unpacked. Otherwise, we would not guarantee the quality.

9.6 Others

When disposing LCD module, obey the local environmental regulations.



Document Name	M125NWF4 R0 Customer Approval Specification			Page 27 of 32	
Document No.	A-M125NWF4-R0-480-02	Made/Revised Date	2018/11/16	Ver.	03

10. EDID Table Format

EDID Table Format					
Address (DEC)	Address (HEX)	Field Name & Comments	Value (HEX)	Value (BIN)	Value (DEC)
0	0	Header	00	00000000	0
1	1	Header	FF	11111111	255
2	2	Header	FF	11111111	255
3	3	Header	FF	11111111	255
4	4	Header	FF	11111111	255
5	5	Header	FF	11111111	255
6	6	Header	FF	11111111	255
7	7	Header	00	00000000	0
8	8	manufacture code	26	100110	38
9	9	manufacture code	CF	11001111	207
10	A	Product Code	E6	11100110	230
11	B	Product Code	04	00000100	4
12	C	LCD module Serial No - ("0" if not used)	00	00000000	0
13	D	LCD module Serial No - ("0" if not used)	00	00000000	0
14	E	LCD module Serial No - ("0" if not used)	00	00000000	0
15	F	LCD module Serial No - ("0" if not used)	00	00000000	0
16	10	Week of manufacture	20	00100000	32
17	11	Year of manufacture	1B	00011011	27
18	12	EDID Structure Ver # = 1	01	00000001	1
19	13	EDID revision # = 3	04	00000100	4
20	14	Video I/P definition = Digital I/P (80h)	A5	10100101	165



Document Name	M125NWF4 R0 Customer Approval Specification			Page 28 of 32	
Document No.	A-M125NWF4-R0-480-02	Made/Revised Date	2018/11/16	Ver.	03

21	15	Max H image size = (Rounded to cm)	1C	00011100	28
22	16	Max V image size = (Rounded to cm)	10	00010000	16
23	17	Display Gamma	78	01111000	120
24	18	Feature support (no DPMS, Active off, RGB, timing BLK 1)	02	00000010	2
25	19	Red/Green Low bits (RxRy/GxGy)	3F	00111111	63
26	1A	Blue/White Low bits (BxBY/WxWy)	00	00000000	0
27	1B	Red X Rx	96	10010110	150
28	1C	Red Y Ry	5A	01011010	90
29	1D	Green X Gx	4F	01001111	79
30	1E	Green Y Gy	8D	10001101	141
31	1F	Blue X Bx	27	00100111	39
32	20	Blue Y By	15	00010101	21
33	21	White X Wx	50	01010000	80
34	22	White Y Wy	54	01010100	84
35	23	Established timings 1 (00h if not used)	00	00000000	0
36	24	Established timing 2 (00h if not used)	00	00000000	0
37	25	Manufacturer@39;s timings (00h if not used)	00	00000000	0
38	26	Standard timing ID1 (01h if not used)	01	00000001	1
39	27	Standard timing ID1 (01h if not used)	01	00000001	1
40	28	Standard timing ID2 (01h if not used)	01	00000001	1
41	29	Standard timing ID2 (01h if not used)	01	00000001	1
42	2A	Standard timing ID3 (01h if not used)	01	00000001	1



Document Name	M125NWF4 R0 Customer Approval Specification			Page 29 of 32	
Document No.	A-M125NWF4-R0-480-02	Made/Revised Date	2018/11/16	Ver.	03

43	2B	Standard timing ID3 (01h if not used)	01	00000001	1
44	2C	Standard timing ID4 (01h if not used)	01	00000001	1
45	2D	Standard timing ID4 (01h if not used)	01	00000001	1
46	2E	Standard timing ID5 (01h if not used)	01	00000001	1
47	2F	Standard timing ID5 (01h if not used)	01	00000001	1
48	30	Standard timing ID6 (01h if not used)	01	00000001	1
49	31	Standard timing ID6 (01h if not used)	01	00000001	1
50	32	Standard timing ID7 (01h if not used)	01	00000001	1
51	33	Standard timing ID7 (01h if not used)	01	00000001	1
52	34	Standard timing ID8 (01h if not used)	01	00000001	1
53	35	Standard timing ID8 (01h if not used)	01	00000001	1
54	36	Pixel Clock LSB	4F	01001111	79
55	37	Pixel Clock HSB	36	00110110	54
56	38	Horizontal Active (lower 8 bits)	80	10000000	128
57	39	Hor blanking (lower 8 bits)	A0	10100000	160
58	3A	Horizontal Active/Horizontal blanking (upper4:4 bits)	70	01110000	112
59	3B	Vertical active(lower 8 bits)	38	00111000	56
60	3C	Vertical blanking(lower 8 bits)	22	00100010	34
61	3D	Vertical Active : Vertical Blanking (upper4:4 bits)	40	01000000	64
62	3E	Horizontal Sync Offset	32	00110010	50
63	3F	Horizontal Sync Pulse Width	3C	00111100	60
64	40	Vertical Sync Offset , Sync	AE	10101110	174



Document Name	M125NWF4 R0 Customer Approval Specification			Page 30 of 32	
Document No.	A-M125NWF4-R0-480-02	Made/Revised Date	2018/11/16	Ver.	03

		Width			
65	41	Horizontal Vertical Sync Offset/Width upper 2 bits	00	00000000	0
66	42	Horizontal Image Size	14	00010100	20
67	43	Vertical image Size	9C	10011100	156
68	44	Horizontal Image Size / Vertical image size	10	00010000	16
69	45	Horizontal Border = (0 for Notebook LCD)	00	00000000	0
70	46	Vertical Border = (0 for Notebook LCD)	00	00000000	0
71	47	Non-interlaced, Normal, no stereo, Separate sync, H/V pol Negatives,	19	00011001	25
72	48	Timing Descriptor #2	00	00000000	0
73	49		00	00000000	0
74	4A		00	00000000	0
75	4B		00	00000000	0
76	4C		00	00000000	0
77	4D		00	00000000	0
78	4E		00	00000000	0
79	4F		00	00000000	0
80	50		00	00000000	0
81	51		00	00000000	0
82	52		00	00000000	0
83	53		00	00000000	0
84	54		00	00000000	0
85	55		00	00000000	0
86	56		00	00000000	0
87	57		00	00000000	0
88	58		00	00000000	0
89	59		00	00000000	0
90	5A	Detailed timing/monitor	00	00000000	0



Document Name	M125NWF4 R0 Customer Approval Specification			Page 31 of 32	
Document No.	A-M125NWF4-R0-480-02	Made/Revised Date	2018/11/16	Ver.	03

		descriptor#3			
91	5B	Flag	00	00000000	0
92	5C	Flag	00	00000000	0
93	5D	Range limits	FE	11111110	254
94	5E	Flag	00	00000000	0
95	5F	Min. Vertical Freq	49	01001001	73
96	60	Max. Vertical Freq	6E	01101110	110
97	61	Min. Horizontal Freq	66	01100110	102
98	62	Max. Horizontal Freq	6F	01101111	111
99	63	Max. Pixel Clock Freq	56	01010110	86
100	64		69	01101001	105
101	65		73	01110011	115
102	66		69	01101001	105
103	67		6F	01101111	111
104	68		6E	01101110	110
105	69	New line character indicates end of ASCII string	0A	00001010	10
106	6A		20	00100000	32
107	6B		20	00100000	32
108	6C	Detailed timing/monitor descriptor #4	00	00000000	0
109	6D		00	00000000	0
110	6E		00	00000000	0
111	6F	FE (hex) defines ASCII string	FE	11111110	254
112	70	Flag	00	00000000	0
113	71	Manufacture P/N	4D	01001101	77
114	72	Manufacture P/N	31	00110001	49
115	73	Manufacture P/N	32	00110010	50
116	74	Manufacture P/N	35	00110101	53
117	75	Manufacture P/N	4E	01001110	78
118	76	Manufacture P/N	57	01010111	87
119	77	Manufacture P/N	46	01000110	70



InfoVision Optoelectronics (Kunshan) Co.,LTD.

Document Name	M125NWF4 R0 Customer Approval Specification			Page 32 of 32	
Document No.	A-M125NWF4-R0-480-02	Made/Revised Date	2018/11/16	Ver.	03

120	78	Manufacture P/N	34	00110100	52
121	79	Manufacture P/N	20	00100000	32
122	7A	Manufacture P/N	52	01010010	82
123	7B	Manufacture P/N	30	00110000	48
124	7C	New line character indicates end of ASCII string	20	00100000	32
125	7D		0A	00001010	10
126	7E	Extension Flag = 00	00	00000000	0
127	7F	Checksum	E3	11100011	227