



InfoVision Optoelectronics (Kunshan)Co., Ltd.

Document Title	M102AWF2 R1 Customer Approved Specification	Page No.	1/28
Document No.		Issue date	2018/12/05
		Revision	00

Customer Approved Specification

To:

Product Name: M102AWF2 R1

Document Issue Date: 2018/12/05

Customer	InfoVision Optoelectronics
<u>SIGNATURE</u>	<u>SIGNATURE</u>
_____	REVIEWED BY
_____	QA
_____	_____
Please return 1 copy for your confirmation with your signature and comments.	PREPARED BY
	FAE

- Note:
1. Please contact IVO Company. before designing your product based on this product.
 2. The information contained herein is presented merely to indicate the characteristics and performance of our products. No responsibility is assumed by IVO for any intellectual property claims or other problems that may result from application based on the module described herein.

FQ-7-30-0-009-03D



InfoVision Optoelectronics (Kunshan)Co., Ltd.

Document Title	M102AWF2 R1 Customer Approved Specification			Page No.	2/28
Document No.		Issue date	2018/12/05	Revision	00

Revision	Date	Page	Old Description	New Description	Note
00	2018/12/05	ALL	—	First issue	—



Document Title	M102AWF2 R1 Customer Approved Specification			Page No.	3/28
Document No.		Issue date	2018/12/05	Revision	00

CONTENTS

1.0 GENERAL DESCRIPTIONS	4
2.0 ABSOLUTE MAXIMUM RATINGS	6
3.0 OPTICAL CHARACTERISTICS	7
4.0 ELECTRICAL CHARACTERISTICS	10
5.0 MECHANICAL CHARACTERISTICS	22
6.0 RELIABILITY CONDITIONS	24
7.0 PACKAGE SPECIFICATION	25
8.0 LOT MARK.....	26
9.0 GENERAL PRECAUTION.....	27

IVO Confidential



InfoVision Optoelectronics (Kunshan)Co., Ltd.

Document Title	M102AWF2 R1 Customer Approved Specification			Page No.	4/28
Document No.		Issue date	2018/12/05	Revision	00

1.0 General Descriptions

1.1 Introduction

The M102AWF2 R1 is a Color Active Matrix Liquid Crystal Display with a back light system. The matrix uses a-Si Thin Film Transistor as a switching device. This TFT LCD has a 10.25 inch diagonally measured active display area with FHD resolution (1,920 horizontal by 720 vertical pixels array).

1.2 Features

- Supported FHD Resolution
- LVDS Interface
- Wide View Angle
- Compatible with RoHS Standard

1.3 Product Summary

Items	Specifications	Unit
Screen Diagonal	10.25	inch
Active Area (H x V)	243.65 x 91.37	mm
Number of Pixels (H x V)	1,920 x 720	-
Pixel Pitch (H x V)	0.1269 x 0.1269	mm
Pixel Arrangement	R.G.B. Vertical Stripe	-
Display Mode	Normally Black	-
White Luminance	(800) (Typ.)	cd /m ²
Contrast Ratio	(1000) (Typ.)	-
Response Time	(20) (Typ.)@25°C	ms
Input Voltage	(3.3) (Typ.)	V
Power Consumption	(7.44) @White pattern, FV=60Hz	W
Weight	(380) (Max.)	g
Outline Dimension (H x V x D) Without PCBA	(262.04) (Typ.) x (110.30)(Typ.) x (8.7) (Max.)	mm
Outline Dimension (H x V x D) With PCBA	(262.04) (Typ.) x (110.30)(Typ.) x (12.2) (Max.)	mm
Electrical Interface (Logic)	LVDS	-
Support Color	16.7 M (8bits)	-
NTSC	TBD	%
Surface Treatment	HC,3H	-
Reflectivity	SCI: (5.5)%(Typ.), (6.0)%(Max.)	-

Note: The Reflectivity measurement tool is CM-700d.

Document Title	M102AWF2 R1 Customer Approved Specification	Page No.	5/28
Document No.		Issue date	2018/12/05
		Revision	00

1.4 Functional Block Diagram

Figure 1 shows the functional block diagram of the LCD module.

Figure 1 Block Diagram

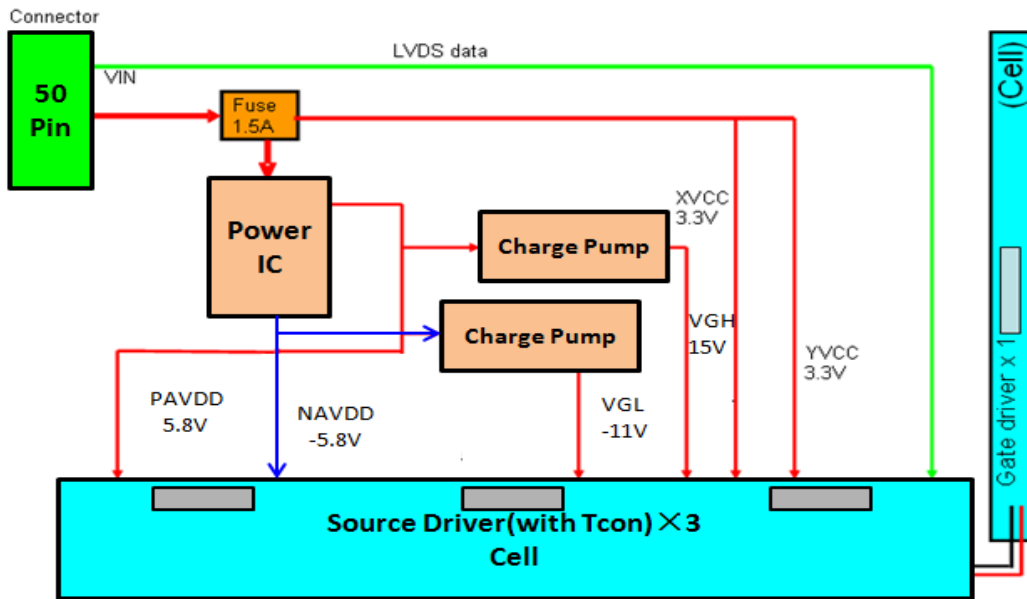

1.5 Pixel Mapping

Figure2 Pixel Mapping

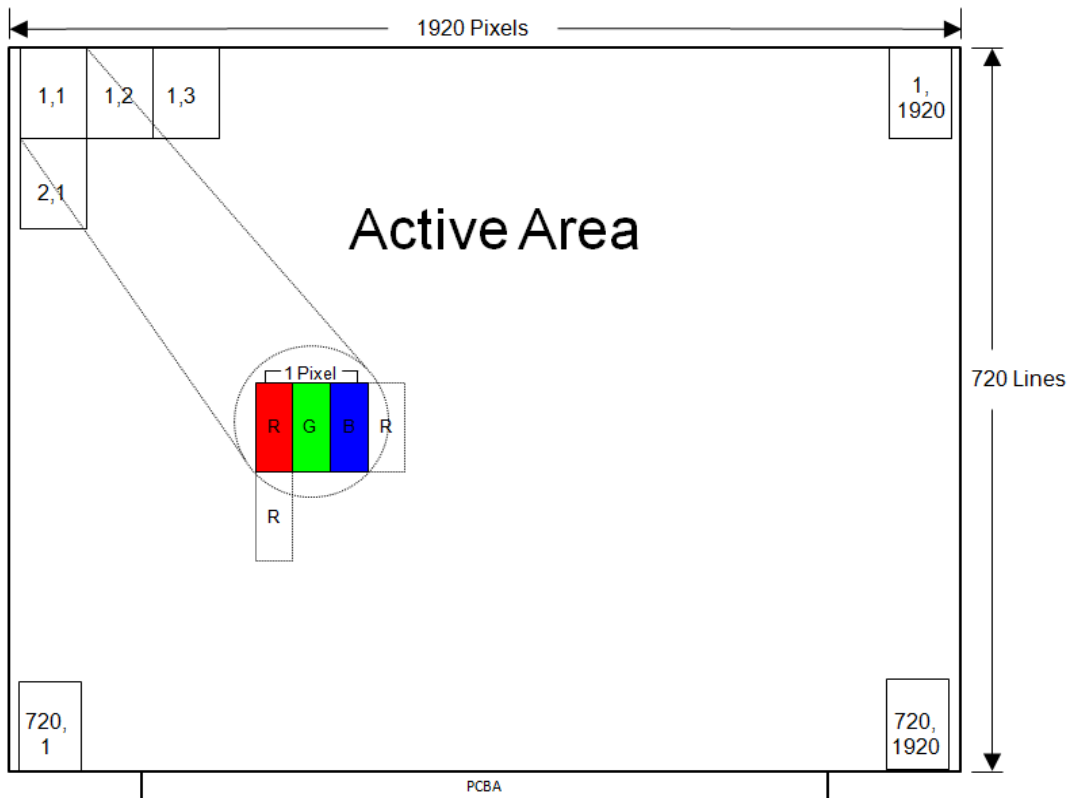

Document Title	M102AWF2 R1 Customer Approved Specification			Page No.	6/28
Document No.		Issue date	2018/12/05	Revision	00

2.0 Absolute Maximum Ratings

Table 1 Electrical & Environment Absolute Rating

Item	Symbol	Min.	Max.	Unit	Note
Logic Supply Voltage	V_{DD}	(-0.3)	(4.0)	V	(1),(2), (3),(4)
Operating Temperature	T_{gs}	(-30)	(85)	°C	
Storage Temperature	T_a	(-40)	(90)	°C	

Note (1) All the parameters specified in the table are absolute maximum rating values that may cause faulty operation or unrecoverable damage, if exceeded. It is recommended to follow the typical value.

Note (2) All the contents of electro-optical specifications and display fineness are guaranteed under Normal Conditions. All the display fineness should be inspected under normal conditions. Normal conditions are defined as follow: Temperature: 25°C, Humidity: 55± 10%RH.

Note (3) Unpredictable results may occur when it was used in extreme conditions. T_a = Ambient Temperature, T_{gs} = Glass Surface Temperature. All the display fineness should be inspected under normal conditions.

Note (4) Temperature and relative humidity range are shown in the figure below. Wet bulb temperature should be lower than 57.8°C, and no condensation of water. Besides, protect the module from static electricity.

Figure 3 Absolute Ratings of Environment of the LCD Module

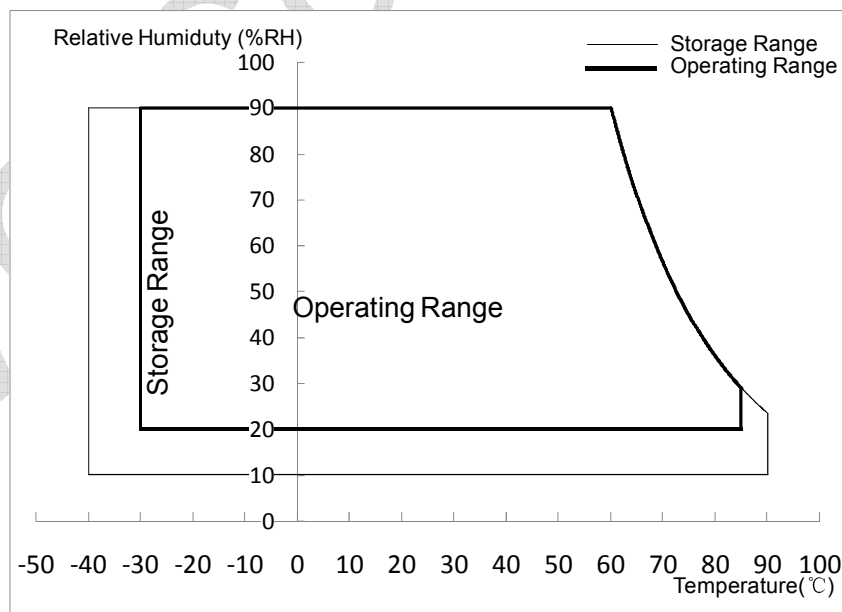



Document Title	M102AWF2 R1 Customer Approved Specification			Page No.	7/28
Document No.		Issue date	2018/12/05	Revision	00

3.0 Optical Characteristics

The optical characteristics are measured under stable conditions as following notes.

Table 2 Optical Characteristics

Item	Conditions		Min.	Typ.	Max.	Unit	Note
Viewing Angle (CR≥10)	Horizontal	θ_{x+}	(80)	(85)	-	degree	(1),(2),(3),(4),(8)
		θ_{x-}	(80)	(85)	-		
	Vertical	θ_{y+}	(80)	(85)	-		
		θ_{y-}	(80)	(85)	-		
Contrast Ratio	Center		(700)	(1000)	-	-	(1),(2),(4),(8) $\theta_x=\theta_y=0^\circ$
Response Time	Rising + Falling	25°C	-	(20)	(30)	ms	(1),(2),(5),(8) $\theta_x=\theta_y=0^\circ$
		-20°C	-	(200)	(250)		
		-30°C	-	(500)	(600)		
Color Chromaticity (CIE1931)	Red	x	(-0.04)	(0.636)	(+0.04)	-	(1),(2),(3),(8) $\theta_x=\theta_y=0^\circ$
	Red	y		(0.322)		-	
	Green	x		(0.320)		-	
	Green	y		(0.632)		-	
	Blue	x		(0.147)		-	
	Blue	y		(0.078)		-	
	White	x		(0.307)		-	
	White	y		(0.335)		-	
NTSC	-		TBD	TBD	-	%	(1),(2),(3),(8) $\theta_x=\theta_y=0^\circ$
White Luminance	Center		(600)	(800)	-	cd/m ²	(1),(2),(6),(8) $\theta_x=\theta_y=0^\circ$
Luminance Uniformity	9 Points		(75)	(80)	-	%	(1),(2),(7),(8) $\theta_x=\theta_y=0^\circ$

Note (1) Measurement Setup:

The LCD module should be stabilized at given ambient temperature (25°C) for 30 minutes to avoid abrupt temperature changing during measuring. In order to stabilize the luminance, the measurement should be executed after lighting backlight for 30 minutes in the windless room.

Document Title	M102AWF2 R1 Customer Approved Specification	Page No.	8/28
Document No.		Issue date	2018/12/05
		Revision	00

Figure 4 Measurement Setup

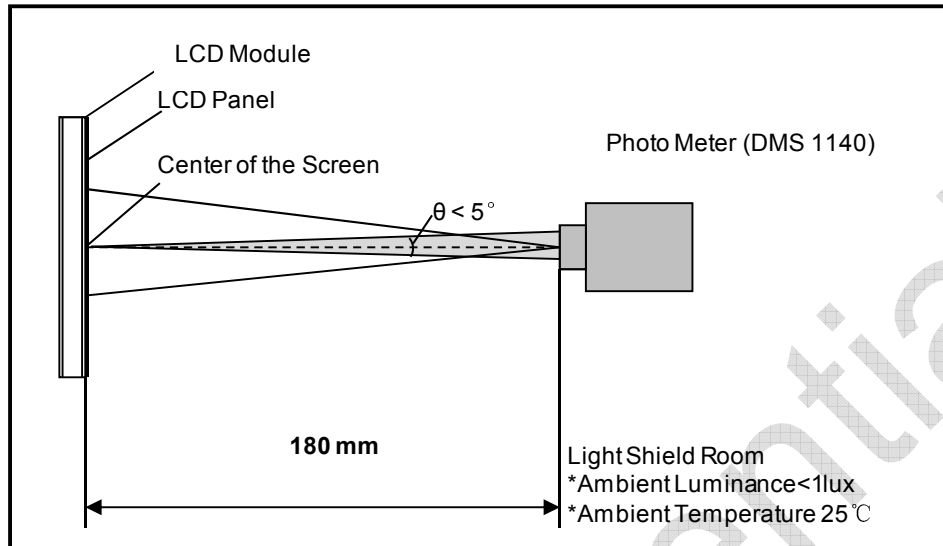

Note (2) The LED input parameter setting as:

$$I_{LED}: (270)\text{mA}$$

Note (3) Definition of Viewing Angle

Figure 5 Definition of Viewing Angle

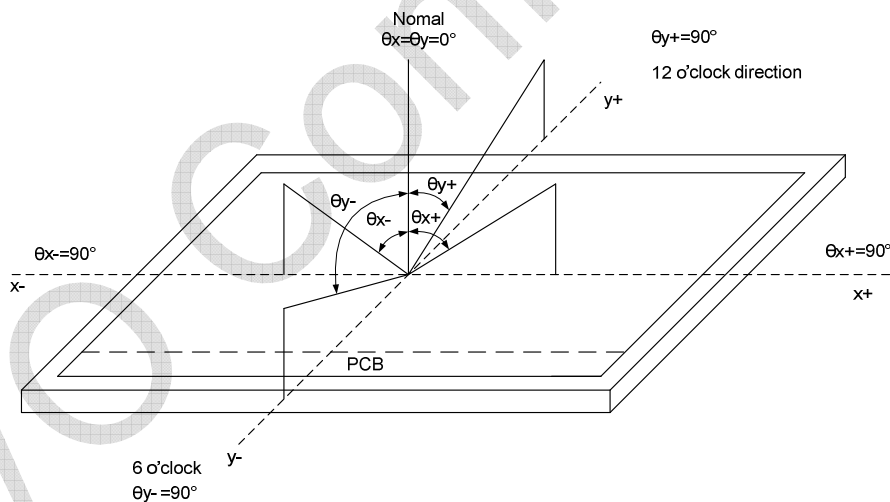

Note (4) Definition of Contrast Ratio (CR)

The contrast ratio can be calculated by the following expression:

$$\text{Contrast Ratio (CR)} = \frac{\text{The luminance of White pattern}}{\text{The luminance of Black pattern}}$$

Note (5) Definition of Response Time (T_R , T_F)

Document Title	M102AWF2 R1 Customer Approved Specification	Page No.	9/28
Document No.		Issue date	2018/12/05
		Revision	00

Figure 6 Definition of Response Time

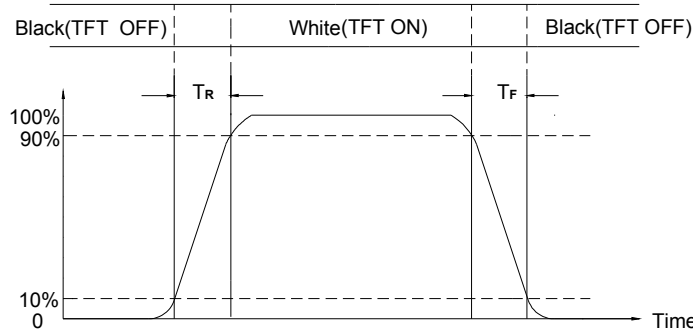

Note (6) Definition of Luminance of White

Measure the luminance of White pattern (Ref.: Active Area)

Display Luminance=L1 (center point)

H—Active Area Width, V—Active Area Height, L—Luminance

Note (7) Definition of Luminance Uniformity (Ref.: Active Area)

Measure the luminance of White pattern at 9 points.

Luminance Uniformity= Min.(L1, L2, ... L9) / Max.(L1, L2, ... L9)

H—Active Area Width, V—Active Area Height, L—Luminance

Figure 7 Measurement Locations of 9 Points

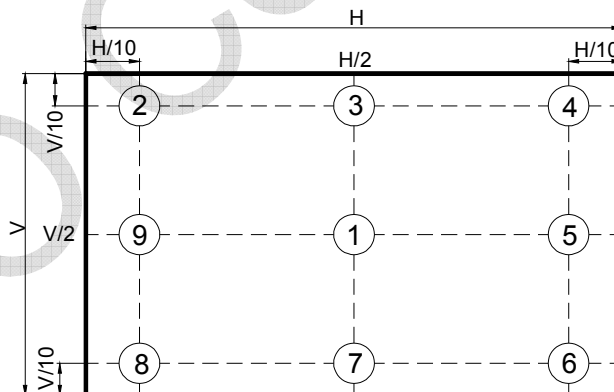

Note (8) All optical data are based on IVO given system & nominal parameter & testing machine in this document.



InfoVision Optoelectronics (Kunshan)Co., Ltd.

Document Title	M102AWF2 R1 Customer Approved Specification			Page No.	10/28
Document No.		Issue date	2018/12/05	Revision	00

4.0 Electrical Characteristics

4.1 Interface Connector

Table 3 Signal Connector Type

Item	Description
Manufacturer / Type	JUSTCONN/101049-205050

Table 4 Signal Connector Pin Assignment

Pin No.	Symbol	Description	Remarks
1	GND	Ground	-
2	GND	Ground	-
3	GND	Ground	-
4	VDD	3.3+/-0.3V	-
5	VDD	3.3+/-0.3V	-
6	VDD	3.3+/-0.3V	-
7	VDD	3.3+/-0.3V	-
8	GND	Ground	-
9	NC	IVO internal used only, Please don't connect by Customer(Serial interface address and data input/output for SPI interface)	-
10	NC	IVO internal used only, Please don't connect by Customer(Serial interface clock input for SPI interface)	-
11	NC	IVO internal used only, Please don't connect by Customer(Serial Interface chip enable signal for SPI interface)	-
12	GND	Ground	-
13	OLV0N	Odd LVDS Data input 0-	-
14	OLV0P	Odd LVDS Data input 0+	-
15	GND	Ground	-
16	OLV1N	Odd LVDS Data input 1-	-
17	OLV1P	Odd LVDS Data input 1+	-
18	GND	Ground	-
19	OLV2N	Odd LVDS Data input 2-	-
20	OLV2P	Odd LVDS Data input 2+	-
21	GND	Ground	-
22	OLVCKN	Odd LVDS Clock input -	-



InfoVision Optoelectronics (Kunshan)Co., Ltd.

Document Title	M102AWF2 R1 Customer Approved Specification		Page No.	11/28	
Document No.		Issue date	2018/12/05	Revision	00

23	OLVCKP	Odd LVDS Clock input +	-
24	GND	Ground	-
25	OLV3N	Odd LVDS Data input 3-	-
26	OLV3P	Odd LVDS Data input 3+	-
27	GND	Ground	-
28	ELV0N	Even LVDS Data input 0-	-
29	ELV0P	Even LVDS Data input 0+	-
30	GND	Ground	-
31	ELV1N	Even LVDS Data input 1-	-
32	ELV1P	Even LVDS Data input 1+	-
33	GND	Ground	-
34	ELV2N	Even LVDS Data input 2-	-
35	ELV2P	Even LVDS Data input 2+	-
36	GND	Ground	-
37	ELVCKN	Even LVDS Clock input -	-
38	ELVCKP	Even LVDS Clock input +	-
39	GND	Ground	-
40	ELV3N	Even LVDS Data input 3-	-
41	ELV3P	Even LVDS Data input 3+	-
42	GND	Ground	-
43	RESET	Global reset pin, active low	-
44	STBYB	Standby mode setting pin, active low	-
45	SHLR	Horizontal shift direction detection,set High or Low,Don't floating	Note1
46	UPDN	Vertical shift direction detection,set High or Low,Don't floating	
47	Fail_T	Output for fail detection	-
48	GND	Ground	-
49	BIST	LCD Panel Self Test Enable ,When it is not used,Connecting to GND is recommended, Don't floating	-
50	NC	IVO internal used only, Please don't connect by Customer(Power input for OTP programming (10V))	-

Note(1) LR: High(2.6~3.6V), UD: High(2.6~3.6V) (Default)



InfoVision Optoelectronics (Kunshan)Co., Ltd.

Document Title	M102AWF2 R1 Customer Approved Specification	Page No.	12/28
Document No.		Issue date	2018/12/05
		Revision	00

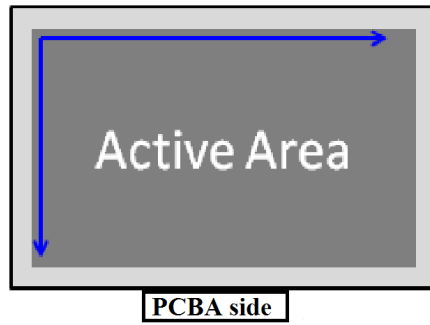

LR: High(2.6~3.6V), UD: Low(0~0.5V)

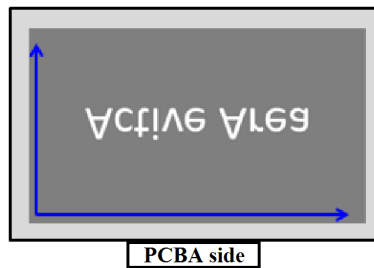

LR: Low(0~0.5V), UD: High(2.6~3.6V)

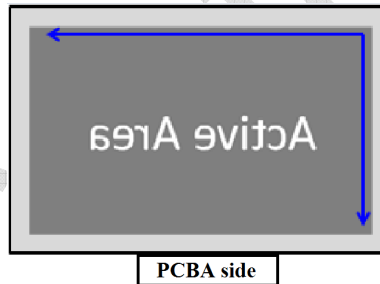

LR: Low(0~0.5V), UD: Low(0~0.5V)

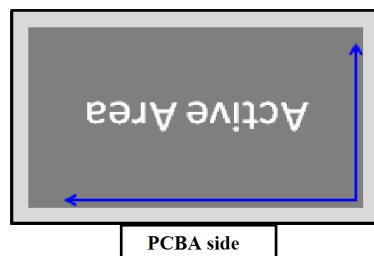



InfoVision Optoelectronics (Kunshan)Co., Ltd.

Document Title	M102AWF2 R1 Customer Approved Specification			Page No.	13/28
Document No.		Issue date	2018/12/05	Revision	00

Table 5 LED FPC Pin Assignment

Pin No.	Symbol	Description	Remarks
1	ADODE1	LED power supply voltage	-
2	ADODE2	LED power supply voltage	-
3	ADODE3	LED power supply voltage	-
4	NC	No Use	-
5	THERMISTORS+	Thermistors	-
6	THERMISTORS-	Thermistors	-
7	NC	No Use	-
8	CATHODE3	LED Cathode (Negative)	-
9	CATHODE2	LED Cathode (Negative)	-
10	CATHODE1	LED Cathode (Negative)	-

Document Title	M102AWF2 R1 Customer Approved Specification			Page No.	14/28
Document No.		Issue date	2018/12/05	Revision	00

4.2 Signal Electrical Characteristics

4.2.1 Signal Electrical Characteristics For LVDS Receiver

The built-in LVDS receiver is compatible with (ANSI/TIA/TIA-644) standard.

Table 6 LVDS Receiver Electrical Characteristics

Parameter	Symbol	Min.	Typ.	Max.	Unit	Conditions
Differential Input High Threshold	V _{th}	-	-	(+300)	mV	V _{CM} =+1.2V
Differential Input Low Threshold	V _{tl}	(-300)	-	-	mV	V _{CM} =+1.2V
Magnitude Differential Input Voltage	V _{ID}	(300)	-	(600)	mV	-
Common Mode Voltage	V _{CM}	(1.0)	(1.2)	(1.4)	V	-
Differential input leakage current	I _{lvleak}	(-10)	-	(10)	mA	-

Note (1) Input signals shall be low or Hi- resistance state when VDD is off.

Note (2) All electrical characteristics for LVDS signal are defined and shall be measured at the interface connector of LCD.

Figure 8 Voltage Definitions

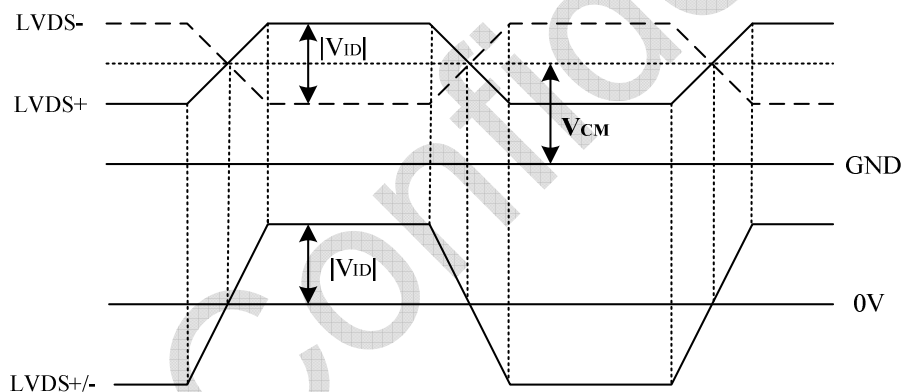

Document Title	M102AWF2 R1 Customer Approved Specification	Page No.	15/28
Document No.		Issue date	2018/12/05
		Revision	00

Figure 9 Measurement System

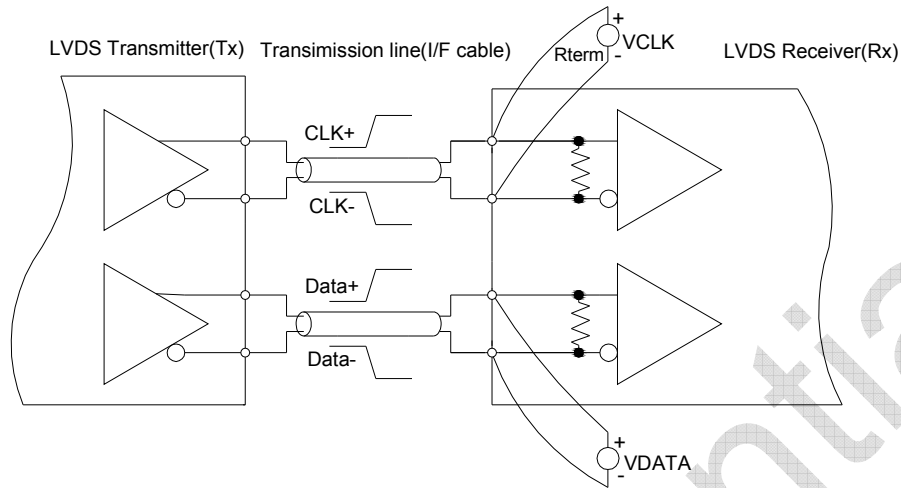
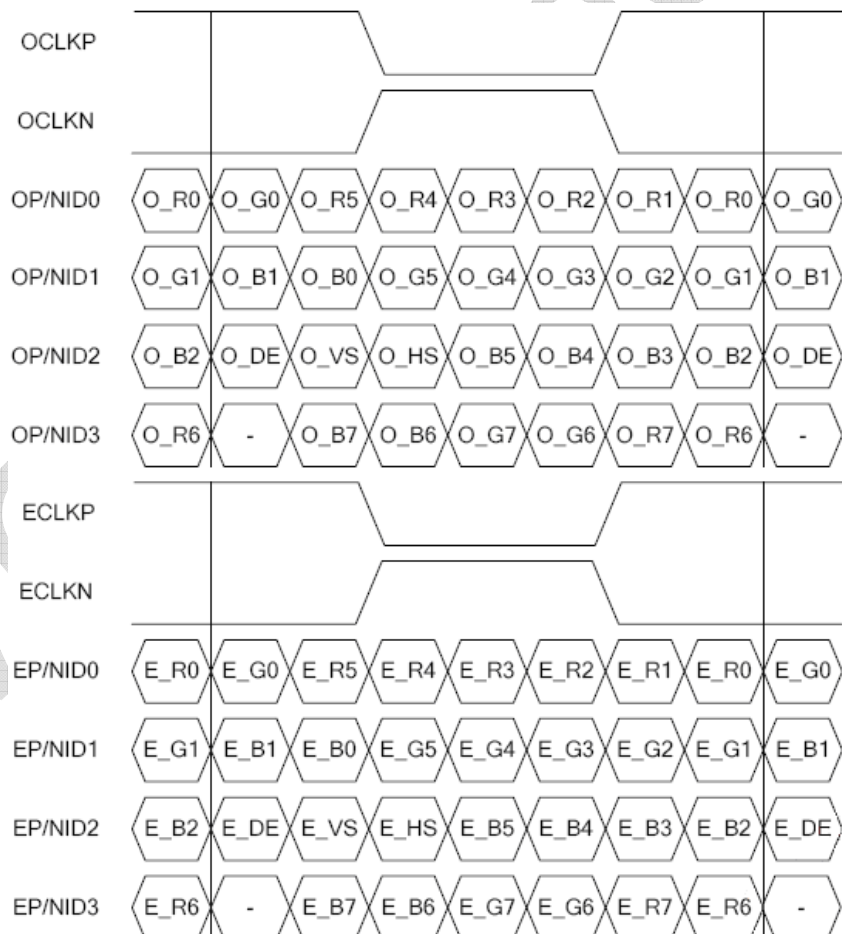

Figure 10 Data Mapping
Single 8 bit LVDS input



Document Title	M102AWF2 R1 Customer Approved Specification	Page No.	16/28
Document No.		Issue date	2018/12/05
		Revision	00

4.2.2 LVDS Receiver Internal Circuit

Figure 11 shows the internal block diagram of the LVDS receiver. This LCD module equips termination resistors for LVDS link.

Figure 11 LVDS Receiver Internal Circuit

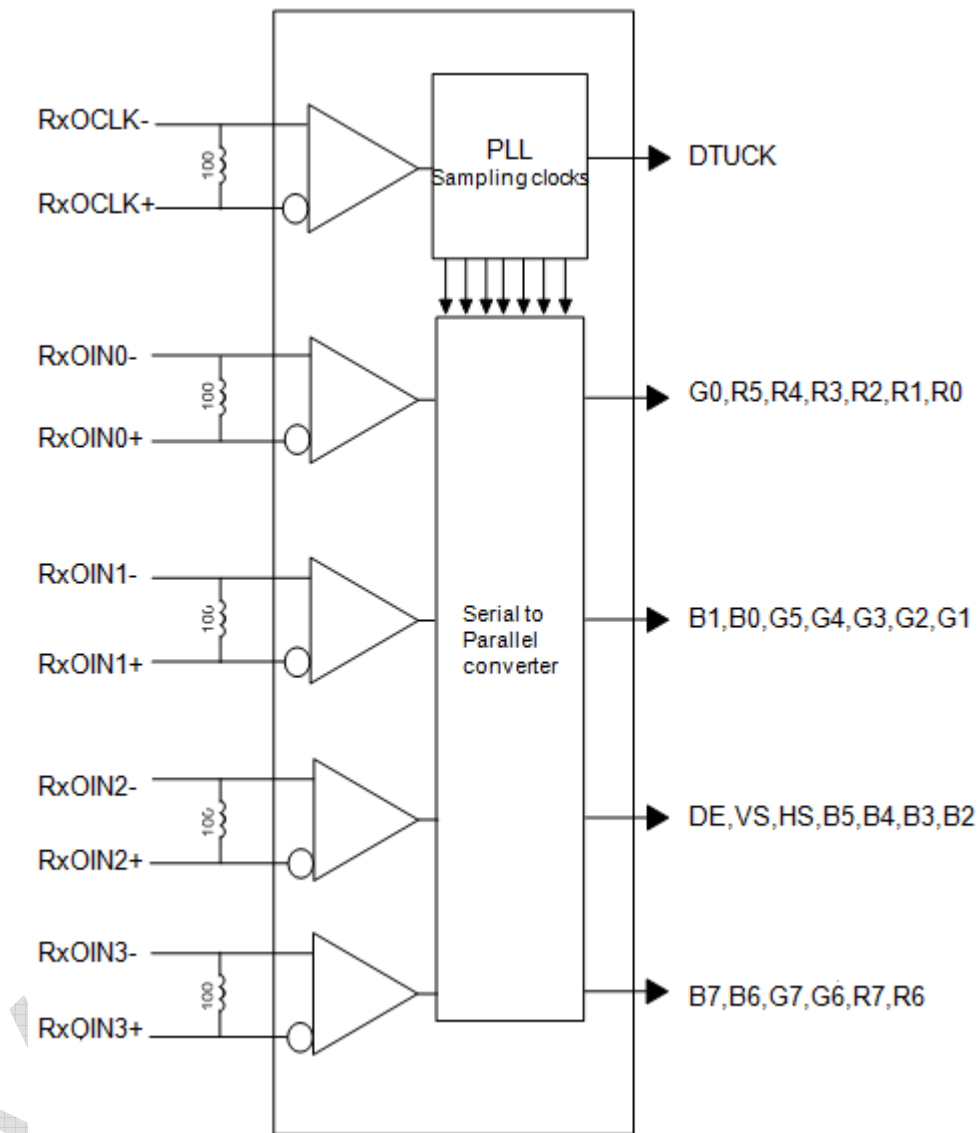

Document Title	M102AWF2 R1 Customer Approved Specification		Page No.	17/28	
Document No.		Issue date	2018/12/05	Revision	00

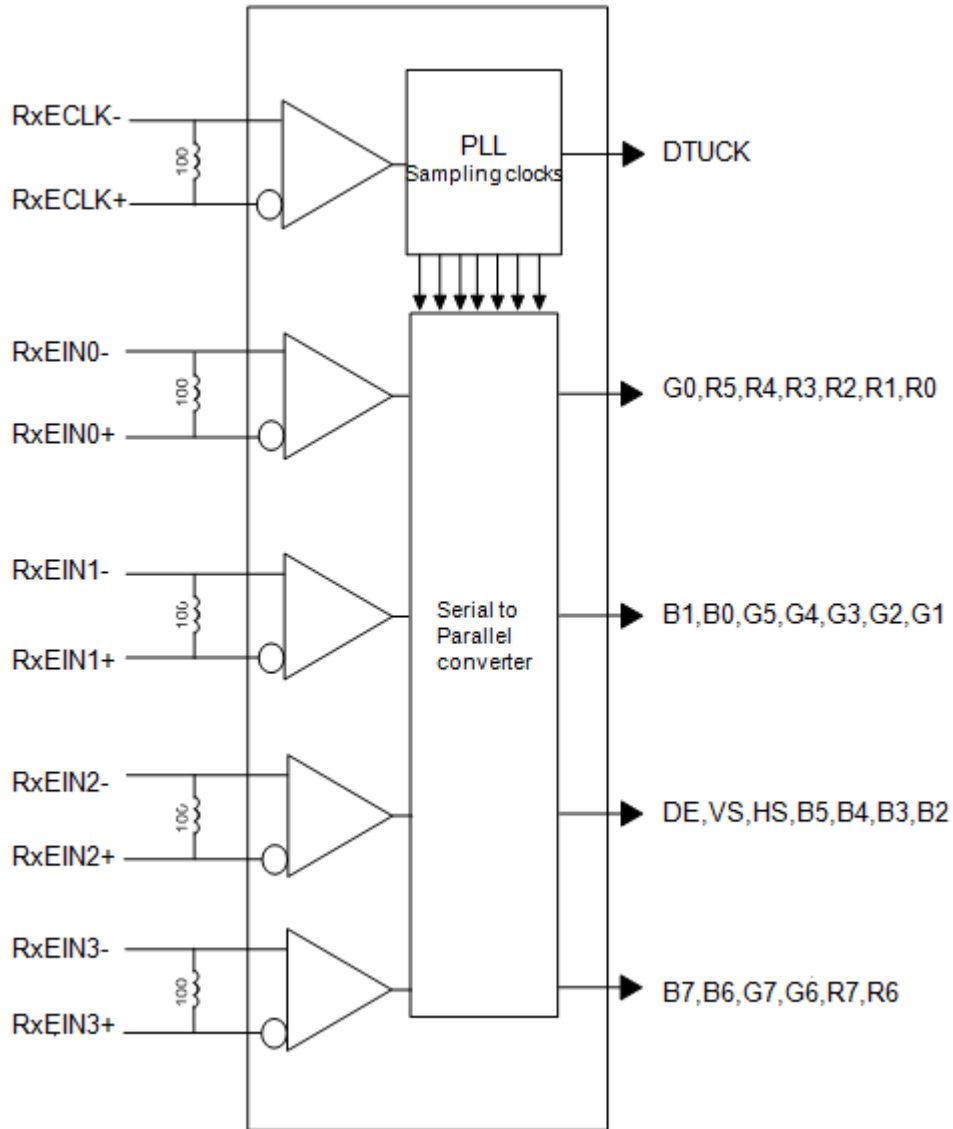



InfoVision Optoelectronics (Kunshan)Co., Ltd.

Document Title	M102AWF2 R1 Customer Approved Specification	Page No.	18/28		
Document No.		Issue date	2018/12/05	Revision	00

4.3 Interface Timings

Table 7 Interface Timings

Parameter	Symbol	Min.	Typ.	Max.	Unit
LVDS Clock Frequency	Fclk	(44.6)	(44.7)	(50.2)	MHz
H Total Time	HT	(1020)	(1024)	(1150)	Clocks
H Active Time	HA	960			Clocks
V Total Time	VT	(726)	(728)	(849)	Lines
V Active Time	VA	720			Lines
Frame Rate	FV	-	(60)	-	Hz

Note1: $HT * VT * \text{Frame Frequency} \leq 50.2 \text{ MHz}$

Note2: Dual link LVDS

Note3: All reliabilities are specified for timing specification based on refresh rate of 60Hz.



Document Title	M102AWF2 R1 Customer Approved Specification			Page No.	19/28
Document No.		Issue date	2018/12/05	Revision	00

4.4 Input Power Specifications

Input power specifications are as follows.

Table 8 Input Power Specifications

Parameter	Symbol	Min.	Typ.	Max.	Unit	Note
<i>System Power Supply</i>						
LCD Drive Voltage (Logic)	V_{DD}	(3)	(3.3)	(3.6)	V	(1),(2)
VDD Current	White pattern I_{DD}	-	-	(95)	mA	(1),(2),(3)
VDD Power Consumption	White pattern P_{DD}	-	-	(313.5)	mW	
LCD Self Test (BIST)	VIH	(2.6)	-	(3.6)	V_{BIST}	
	VIL	(0)	-	(0.5)		
Horizontal Reverse Scan	VIH	(2.6)	-	(3.6)	V_{LR}	
	VIL	(0)	-	(0.5)		
Vertical Reverse Scan	VIH	(2.6)	-	(3.6)	V_{UD}	
	VIL	(0)	-	(0.5)		
RESET	VIH	(2.6)	-	(3.6)	V_{RST}	
	VIL	(0)	-	(0.5)		
Rush Current	I_{Rush}	-	-	TBD	A	(1),(4)
Allowable Logic/LCD Drive Ripple Voltage	V_{VDD-RP}	-	-	TBD	mV	
<i>LED Power Supply</i>						
LED Input Voltage	V_{LED}	-	-	(26.4)	V	(1),(2),(6),(7)
LED Power Consumption	P_{LED}	-	-	(7.13)	W	
LED Forward Voltage	V_F	-	-	(3.3)	V	
LED Forward Current	@25°C I_{F1}	-	(90)	-	mA	
	@85°C I_{F2}	-	TBD	-	mA	(2),(6),(7)
LED Life Time	LT	(10,000)	-	-	Hours	(1),(5)

Note (1) All of the specifications are guaranteed under normal conditions. Normal conditions are defined as follow: Temperature: 25°C, Humidity: 55± 10%RH.

Note (2) All of the absolute maximum ratings specified in the table, if exceeded, may cause faulty operation or unrecoverable damage. It is recommended to follow the typical value.

Note (3) The specified V_{DD} current and power consumption are measured under the $V_{DD} = 3.3 V$,

Document Title	M102AWF2 R1 Customer Approved Specification		Page No.	20/28	
Document No.		Issue date	2018/12/05	Revision	00

FV= 60 Hz condition and white pattern.

Note (4) The figures below is the measuring condition of V_{DD} . Rush current can be measured when T_{RUSH} is 0.5 ms.

Figure 12 V_{DD} Rising Time

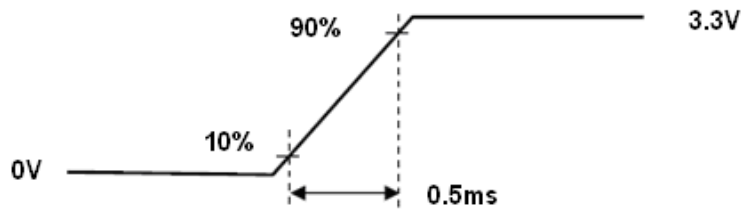

Note (5) The life time is determined as the sum of the lighting time till the luminance of LCD at the typical LED current reducing to 50% of the minimum value under normal operating condition.

Note (6) Definition of VLED and PLED

$$VLED = VF \times 8, ILED = IF \times 3, PLED = VLED \times ILED$$

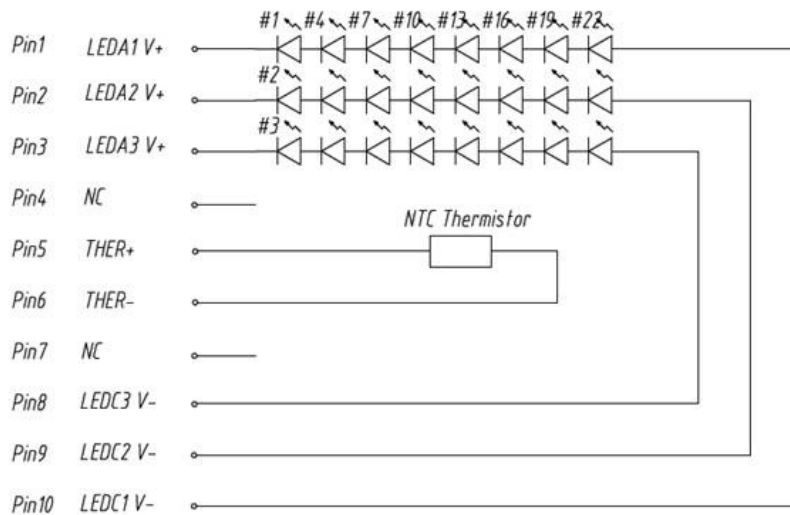

Note (7) Backlight operation must be follow diagram of Ambient temperature and Allowed forward current.

TBD



Document Title	M102AWF2 R1 Customer Approved Specification			Page No.	21/28
Document No.		Issue date	2018/12/05	Revision	00

4.5 Power ON/OFF Sequence

1. Interface signals are also shown in the chart. Signals from any system shall be Hi-resistance state or low level when VDD voltage is off.
2. When system first start up, should keep the VDD high time longer than 200ms, otherwise may cause image sticking when VDD drop off.

Figure 13 Power Sequence

TBD

IVO Confidential

Document Title	M102AWF2 R1 Customer Approved Specification	Page No.	22/28
Document No.		Issue date	2018/12/05
		Revision	00

5.0 Mechanical Characteristics

5.1 Outline Drawing

Figure 14 Reference Outline Drawing (Front Side)

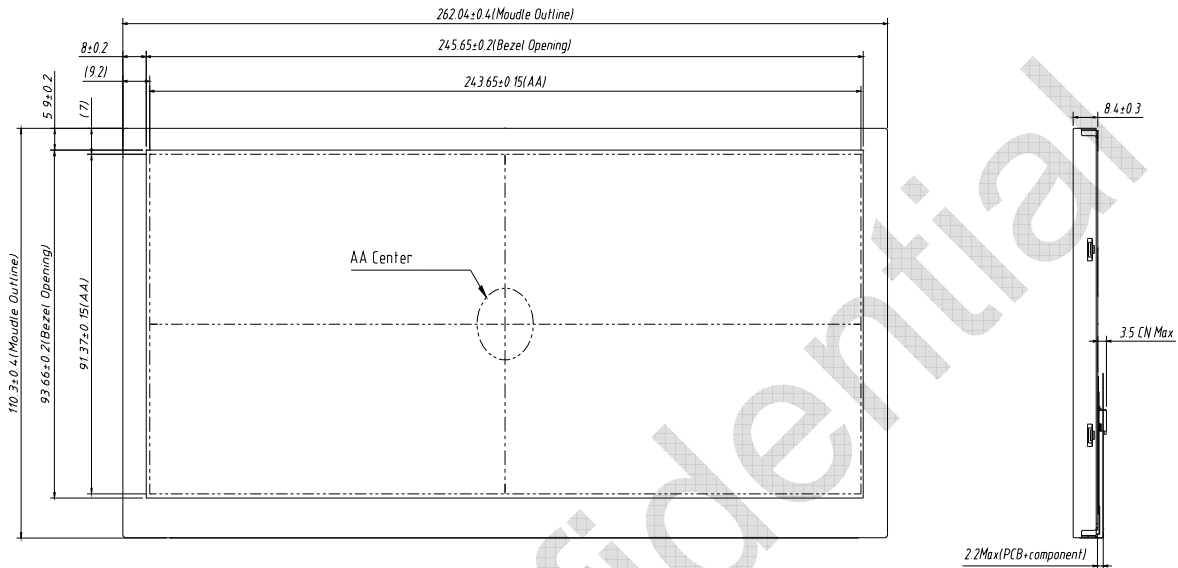

Unit:mm

Figure 15 Reference Outline Drawing (Back Side)

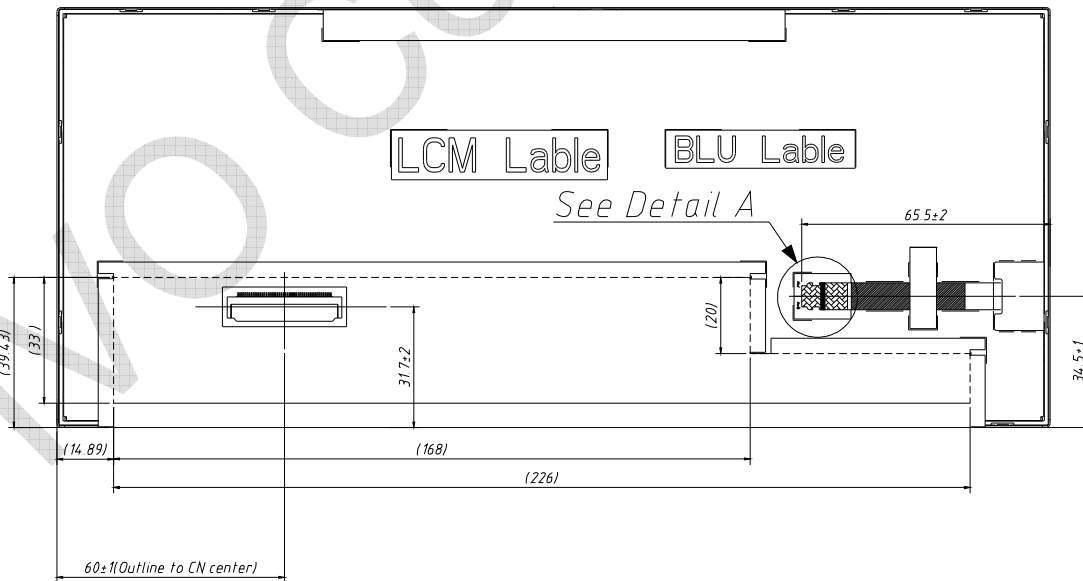

Document Title	M102AWF2 R1 Customer Approved Specification	Page No.	23/28
Document No.		Issue date	2018/12/05
		Revision	00

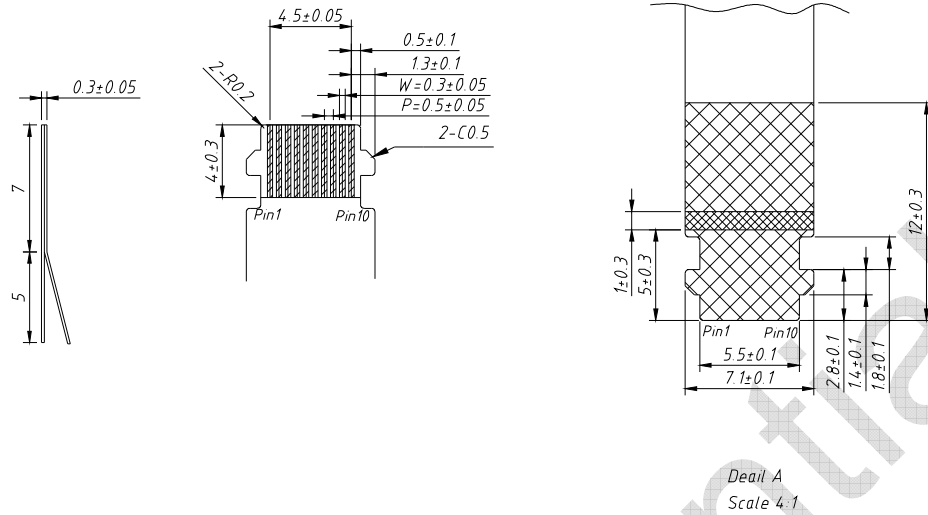

Unit:mm

Note: Not marked tolerance is ± 0.5 mm.

5.2 Dimension Specifications

Table 9 Module Dimension Specifications

Item	Min.	Typ.	Max.	Unit
Width	(261.64)	(262.04)	(262.44)	mm
Height	(109.90)	(110.30)	(110.70)	mm
Thickness	Without PCBA	-	(8.7)	mm
	With PCBA	-	(12.2)	mm
Weight	-	-	(380)	g
BM: a-b & c-d	-	-	(1.0)	mm

Note: Outline dimension measure instrument: Vernier Caliper.

Figure 16 BM Area

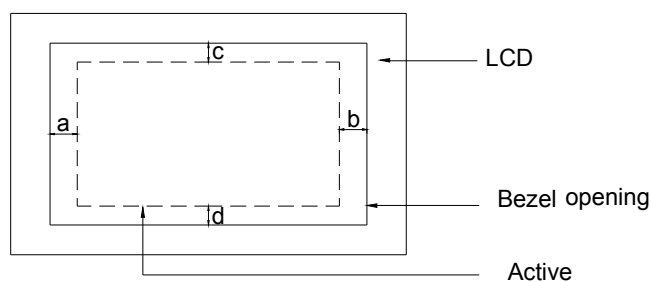



Document Title	M102AWF2 R1 Customer Approved Specification			Page No.	24/28
Document No.		Issue date	2018/12/05	Revision	00

6.0 Reliability Conditions**Table 10 Reliability Condition**

Item		Package	Test Conditions		Note
High Temperature/High Humidity Operating Test		Module	T _{gs} =60°C, 90%RH, 500 hours		(1),(2),(3),(4)
High Temperature Operating Test		Module	T _{gs} =85°C, 500 hours		
Low Temperature Operating Test		Module	T _a = -30°C, 500 hours		(1),(2),(3),(4)
High Temperature Storage Test		Module	T _a =90°C, 500 hours		(1),(3),(4)
Low Temperature Storage Test		Module	T _a = -40°C, 500 hours		
Shock Non-operating Test		Module	100*9.8m/s ² , t=6ms,XYZ directions Half sin curve,each directions 2times		(1),(3),(5)
Vibration Non-operating Test		Module	Frequency:8-33.3Hz Total amplitude:1.3mm Frequency:33.3-400Hz Acceleration:29.4m/s ² sweep time 15minutes 2hours each for X and Z, directions, 4hours for Y, directions		
ESD Test	Operating	Module	Contact	±8KV ,150pF(330Ohm)	(1),(2),(6)
			Air	±15KV ,150pF(330Ohm)	

Note (1) A sample can only have one test. Outward appearance, image quality and optical data can only be checked at normal conditions according to the IVO document before reliable test. Only check the function of the module after reliability test.

Note (2) The setting of electrical parameters should follow the typical value before reliability test.

Note (3) During the test, it is unaccepted to have condensate water remains. Besides, protect the module from static electricity.

Note (4) The sample must be released for 24 hours under normal conditions before judging.

Furthermore, all the judgment must be made under normal conditions. Normal conditions are defined as follow: Temperature: 25°C, Humidity: 55± 10%RH. T_a= Ambient Temperature, T_{gs}= Glass Surface Temperature.

Note (5) The module should be fixed firmly in order to avoid twisting and bending.

Note (6) It could be regarded as pass, when the module recovers from function fault caused by ESD by oneself.

Document Title	M102AWF2 R1 Customer Approved Specification	Page No.	25/28
Document No.		Issue date	2018/12/05
		Revision	00

7.0 Package Specification

Figure 18 Packing Method

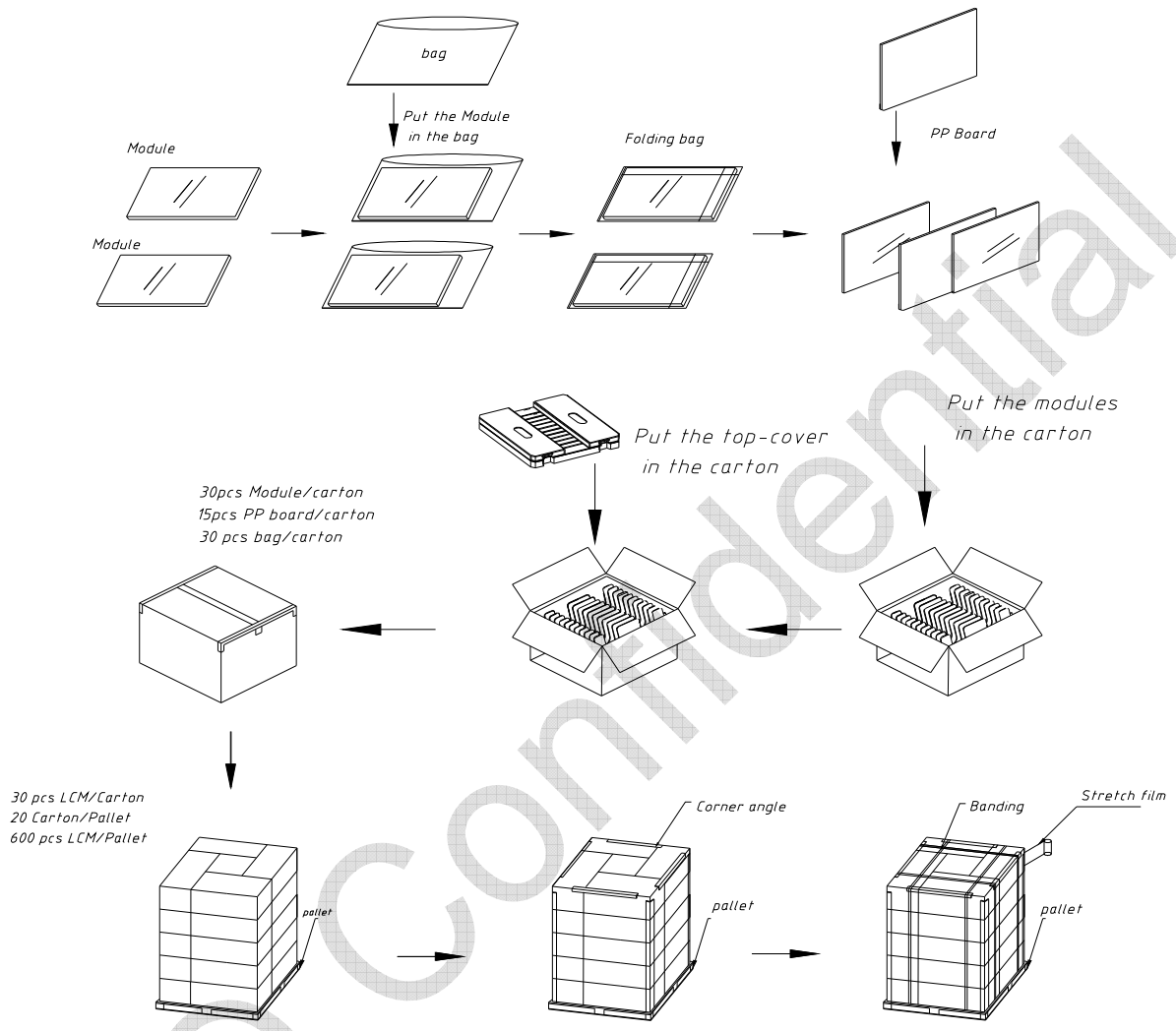



InfoVision Optoelectronics (Kunshan)Co., Ltd.

Document Title	M102AWF2 R1 Customer Approved Specification	Page No.	26/28		
Document No.		Issue date	2018/12/05	Revision	00

8.0 Lot Mark

TBD

IVO Confidential



Document Title	M102AWF2 R1 Customer Approved Specification			Page No.	27/28
Document No.		Issue date	2018/12/05	Revision	00

9.0 General Precaution

9.1 Using Restriction

This product is not authorized for using in life supporting systems, aircraft navigation control systems, military systems and any other appliance where performance failure could be life-threatening or lead to be catastrophic.

9.2 Operation Precaution

(1)The LCD product should be operated under normal conditions.

Normal conditions are defined as below:

Temperature: 25°C

Humidity: 55±10%

Display pattern: continually changing pattern (Not stationary)

(2) Brightness and response time depend on the temperature. (It needs more time to reach normal brightness in low temperature.)

(3) It is necessary for you to pay attention to condensation when the ambient temperature drops suddenly. Condensate water would damage the polarizer and electrical contacted parts of the module. Besides, smear or spot will remain after condensate water evaporating.

(4) If the absolute maximum rating value was exceeded, it may damage the module.

(5) Do not adjust the variable resistor located on the module.

(6) Sufficient suppression to the electromagnetic interference shall be done by system manufacturers. Grounding and shielding may be important to minimize the interference.

(7) Image sticking may occur when the module displayed the same pattern for long time.

(8) Do not connect or disconnect the module in the “power on” condition. Power supply should always be turned on/off by the “power on/off sequence”

(9) Ultra-violet ray filter is necessary for outdoor operation.

9.3 Mounting Precaution

(1) All the operators should be electrically grounded and with Ion-blown equipment turning on when mounting or handling. Dressing finger-stalls out of the gloves is important for keeping the panel clean during the incoming inspection and the process of assembly.

(2) It is unacceptable that the material of cover case contains acetic or chloric. Besides, any other material that could generate corrosive gas or cause circuit break by electro-chemical reaction is not desirable.

(3) The case on which a module is mounted should have sufficient strength so that external force is not transmitted to the module directly.

(4) It is obvious that you should adopt radiation structure to satisfy the temperature specification.

(5) So as to acquire higher luminance, the cable of the power supply should be connected directly with a minimize length.

(6) It should be attached to the system tightly by using all holes for mounting, when the module is



InfoVision Optoelectronics (Kunshan)Co., Ltd.

Document Title	M102AWF2 R1 Customer Approved Specification			Page No.	28/28
Document No.		Issue date	2018/12/05	Revision	00

assembled. Be careful not to apply uneven force to the module, especially to the PCB on the back.

(7) A transparent protective film needs to be attached to the surface of the module.

(8) Do not press or scratch the polarizer exposed with anything harder than HB pencil lead. In addition, don't touch the pin exposed with bare hands directly.

(9) Clean the polarizer gently with absorbent cotton or soft cloth when it is dirty.

(10) Wipe off saliva or water droplet as soon as possible. Otherwise, it may cause deformation and fading of color.

(11) Desirable cleaners are IPA (Isopropyl Alcohol) or hexane. Do not use Ketone type materials (ex. Acetone), Ethyl alcohol, Toluene, Ethyl acid or Methyl chloride. It might permanent damage to the polarizer due to chemical reaction.

(12) Do not disassemble or modify the module. It may damage sensitive parts in the LCD module, and cause scratches or dust remains. IVO does not warrant the module, if you disassemble or modify the module.

9.4 Handling Precaution

(1) Static electricity will generate between the film and polarizer, when the protection film is peeled off. It should be peeled off slowly and carefully by operators who are electrically grounded and with Ion-blown equipment turning on. Besides, it is recommended to peel off the film from the bonding area.

(2) The protection film is attached to the polarizer with a small amount of glue. When the module with protection film attached is stored for a long time, a little glue may remain after peeling.

(3) If the liquid crystal material leaks from the panel, keep it away from the eyes and mouth. In case of contact with hands, legs or clothes, it must be clean with soap thoroughly.

9.5 Storage Precaution

When storing modules as spares for long time, the following precautions must be executed.

(1) Store them in a dark place. Do not expose to sunlight or fluorescent light. Keep the temperature between 5°C and 35°C at normal humidity.

(2) The polarizer surface should not come in contact with any other object. It is recommended that they be stored in the container in which they were shipped.

(3) It is recommended to use it in a short-time period, after it's unpacked. Otherwise, we would not guarantee the quality.

9.6 Others

When disposing LCD module, obey the local environmental regulations.