

Document Title	M156GWFA R0 Tentative Product Specification		Page No.	1/24	
Document No.		Issue date	2022/04/01	Revision	00

Tentative Product Specification

To:

Product Name: M156GWFA R0

Document Issue Date: 2022/04/01

Customer	InfoVision Optoelectronics
<p><u>SIGNATURE</u></p> <p>_____</p> <p>_____</p> <p>_____</p> <p>Please return 1 copy for your confirmation with your signature and comments.</p>	<p><u>SIGNATURE</u></p> <p>REVIEWED BY CQM</p> <p>_____</p> <p>PREPARED BY FAE</p> <p>_____</p>

Note : 1. Please contact InfoVision Company before designing your product based on this product.
 2. The information contained herein is presented merely to indicate the characteristics and performance of our products. No responsibility is assumed by IVO for any intellectual property claims or other problems that may result from application based on the module described herein.

IVO InfoVision Optoelectronics (Kunshan) Co.,LTD.

Document Title	M156GWFA R0 Tentative Product Specification			Page No.	2/24
Document No.		Issue date	2022/04/01	Revision	00

Revision	Date	Page	Revised Content/Summary	Remark
00	2022/04/01	-	First issued.	

IVO Confidential document

Document Title	M156GWFA R0 Tentative Product Specification		Page No.	3/24	
Document No.		Issue date	2022/04/01	Revision	00

CONTENTS

1.0	GENERAL DESCRIPTIONS	3
2.0	ABSOLUTE MAXIMUM RATINGS	5
3.0	OPTICAL CHARACTERISTICS.....	6
4.0	ELECTRICAL CHARACTERISTICS.....	9
5.0	MECHANICAL CHARACTERISTICS.....	17
6.0	RELIABILITY CONDITIONS	19
7.0	PACKAGE SPECIFICATION	21
8.0	LOT MARK	22
9.0	GENERAL PRECAUTION	23

Document Title	M156GWFA R0 Tentative Product Specification		Page No.	4/24	
Document No.		Issue date	2022/04/01	Revision	00

1.0 General Descriptions

1.1 Introduction

The M156GWFA R0 is a Color Active Matrix Liquid Crystal Display with a back light system. The matrix uses a-Si Thin Film Transistor as a switching device. This TFT LCD has a 15.6 inch diagonally measured active display area with FHD resolution (1,920 horizontal by 1,080 vertical pixels array).

1.2 Features

- Supported FHD Resolution
- LVDS Interface
- Wide View Angle
- Compatible with RoHS Standard

1.3 Product Summary

Items	Specifications	Unit
Screen Diagonal	15.6	inch
Active Area (H x V)	344.16 x 193.59	mm
Number of Pixels (H x V)	1,920 x 1,080	-
Pixel Pitch (H x V)	0.17925 x 0.17925	mm
Pixel Arrangement	R.G.B. Vertical Stripe	-
Display Mode	Normally Black	-
White Luminance	(1,000) (Typ.)	cd /m ²
Contrast Ratio	(1,000) (Typ.)	-
Response Time	(35) (Max.)	ms
Input Voltage	3.3 (Typ.)	V
Power Consumption	(27.8) (Max.)	W
Weight	(990) (Max.)	g
Outline Dimension (H x V x D)	(363.80) (Typ.) x (215.90)(Typ.) x (9.32) (Max.)	mm
Electrical Interface (Logic)	LVDS	-
Support Color	16.7 M	-
NTSC	(72) (Typ.)	%
Viewing Direction	All	-
Surface Treatment	AG+3H	-

Document Title	M156GWFA R0 Tentative Product Specification		Page No.	5/24	
Document No.		Issue date	2022/04/01	Revision	00

1.4 Functional Block Diagram

Figure 1 shows the functional block diagram of the LCD module.

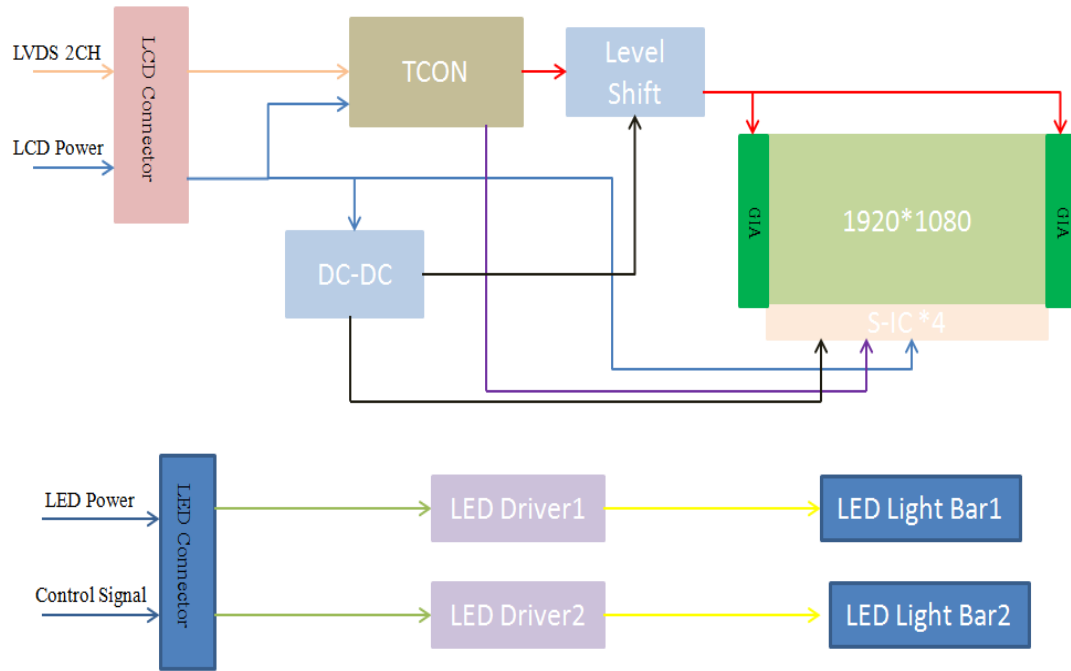

Figure 1 Block Diagram

1.5 Pixel Mapping

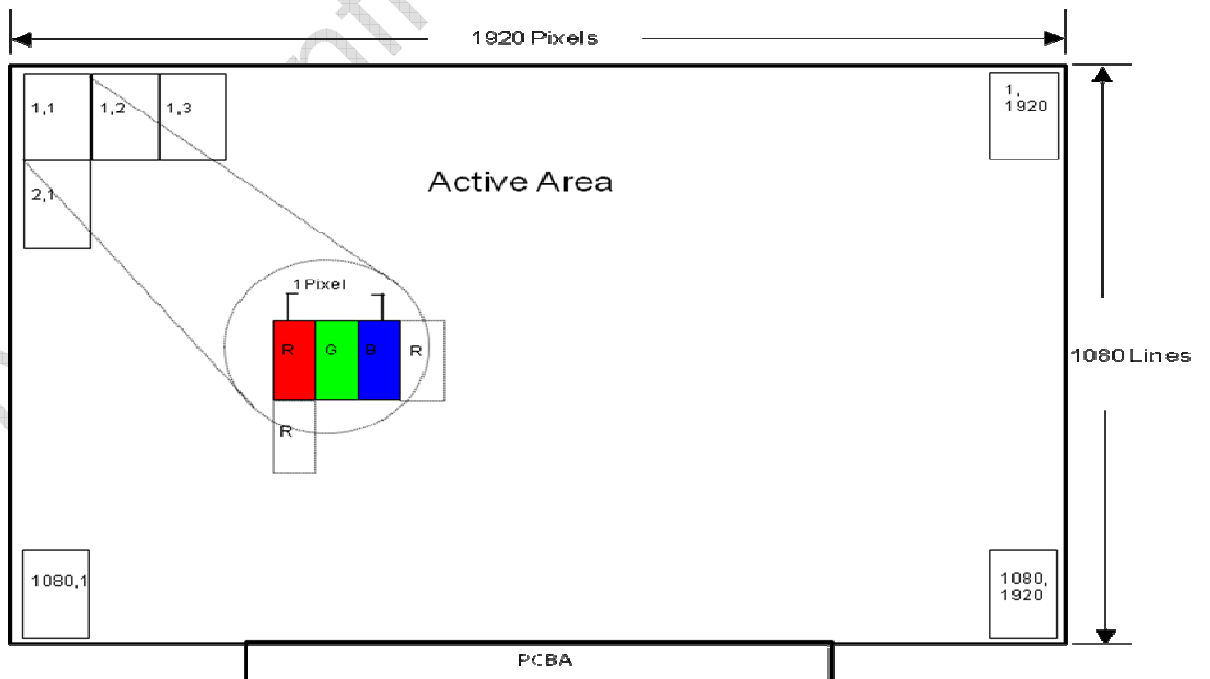

Figure2 Pixel Mapping

Document Title	M156GWFA R0 Tentative Product Specification			Page No.	6/24
Document No.		Issue date	2022/04/01	Revision	00

2.0 Absolute Maximum Ratings

Table 1 Electrical & Environment Absolute Rating

Item	Symbol	Min.	Max.	Unit	Note
Logic Supply Voltage	V_{DD}	(-0.3)	(4.0)	V	(1),(2), (3),(4)
Operating Temperature	T_{gs}	(-30)	(85)	°C	
Storage Temperature	T_a	(-30)	(85)	°C	

Note (1) All the parameters specified in the table are absolute maximum rating values that may cause faulty operation or unrecoverable damage, if exceeded. It is recommended to follow the typical value.

Note (2) All the contents of electro-optical specifications and display fineness are guaranteed under Normal Conditions. All the display fineness should be inspected under normal conditions. Normal conditions are defined as follow: Temperature: 25°C, Humidity: 55± 10%RH.

Note (3) Unpredictable results may occur when it was used in extreme conditions. T_a = Ambient Temperature, T_{gs} = Glass Surface Temperature. All the display fineness should be inspected under normal conditions.

Note (4) Temperature and relative humidity range are shown in the figure below. Wet bulb temperature should be lower than 38.3 °C and no condensation of water. Besides, protect the module from static electricity.

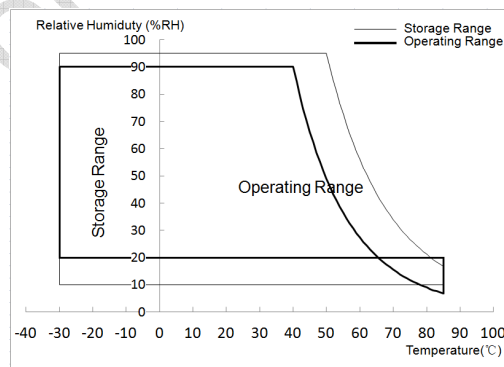

Figure 3 Absolute Ratings of Environment of the LCD Module

Document Title	M156GWFA R0 Tentative Product Specification			Page No.	7/24
Document No.		Issue date	2022/04/01	Revision	00

3.0 Optical Characteristics

The optical characteristics are measured under stable conditions as following notes.

Table 2 Optical Characteristics

Item	Conditions	Min.	Typ.	Max.	Unit	Note		
Viewing Angle (CR≥10)	Horizontal	θ_{x+}	(80)	(85)	-	degree (1),(2),(3),(4),(8)		
		θ_{x-}	(80)	(85)	-			
	Vertical	θ_{y+}	(80)	(85)	-			
		θ_{y-}	(80)	(85)	-			
Contrast Ratio	Center	(700)	(1,000)	-	-	(1),(2),(4),(8) $\theta_x=\theta_y=0^\circ$		
Response Time	Rising + Falling	-	(25)	(35)	ms	(1),(2),(5),(8) $\theta_x=\theta_y=0^\circ$		
Color Chromaticity (CIE1931)	Red x	TBD	TBD	TBD	-	(1),(2),(3),(8) $\theta_x=\theta_y=0^\circ$		
	Red y		TBD		-			
	Green x		TBD		-			
	Green y		TBD		-			
	Blue x		TBD		-			
	Blue y		TBD		-			
	White x		Typ.		(0.313)		Typ.	-
	White y		-0.05		(0.329)		+0.05	-
NTSC	-	TBD	(72)	-	%	(1),(2),(3),(8) $\theta_x=\theta_y=0^\circ$		
White Luminance	Center	(800)	(1,000)	-	cd/m ²	(1),(2),(6),(8) $\theta_x=\theta_y=0^\circ$		
Luminance Uniformity	9 Points	(75)	(80)	-	%	(1),(2),(7),(8) $\theta_x=\theta_y=0^\circ$		

Note (1) Measurement Setup:

The LCD module should be stabilized at given temperature(25℃) for 30 minutes to avoid abrupt temperature changing during measuring. In order to stabilize the luminance, the measurement should be executed after lighting backlight for 30 minutes in a windless room.

Document Title	M156GWFA R0 Tentative Product Specification		Page No.	8/24	
Document No.		Issue date	2022/04/01	Revision	00

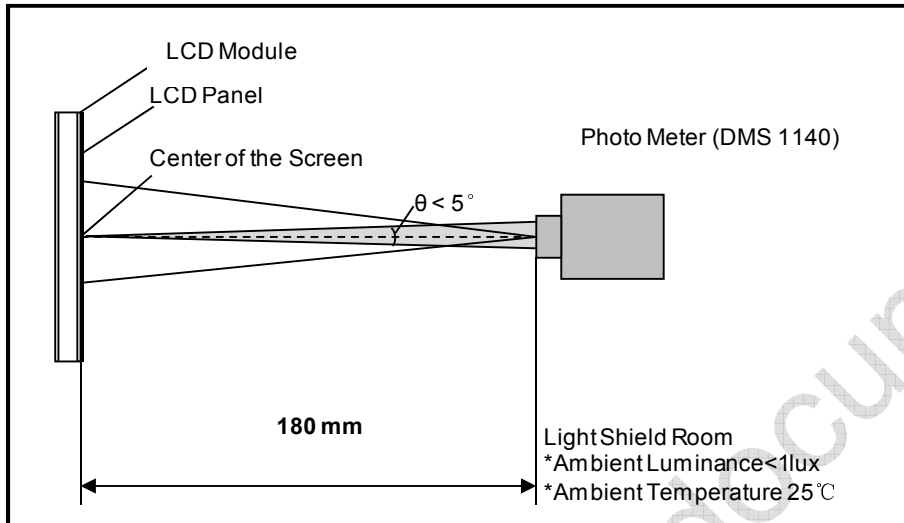

Figure 4 Measurement Setup

Note (2) The LED input parameter setting as:

PWM_LED: Duty 100 %

Note (3) Definition of Viewing Angle

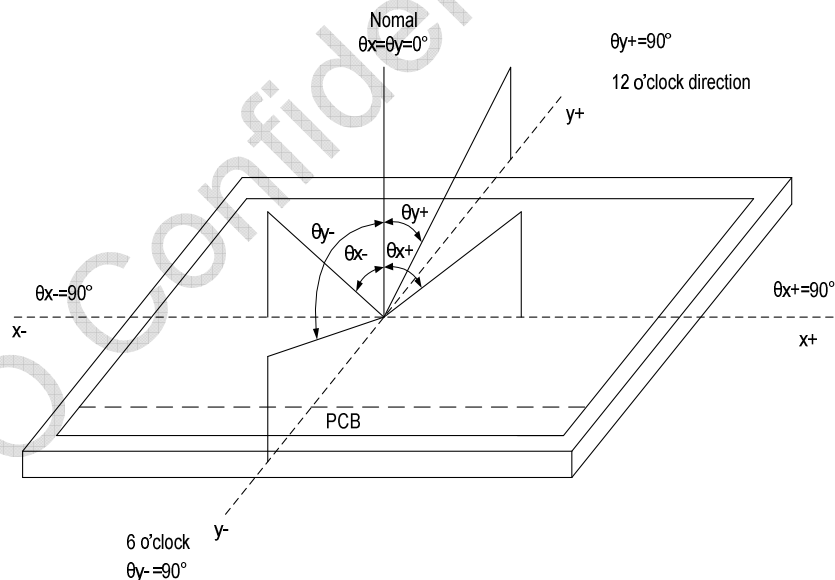

Figure 5 Definition of Viewing Angle

Note (4) Definition of Contrast Ratio (CR)

The contrast ratio can be calculated by the following expression:

Contrast Ratio (CR) = The luminance of White pattern/ The luminance of Black pattern

Note (5) Definition of Response Time (T_R , T_F)

Document Title	M156GWFA R0 Tentative Product Specification		Page No.	9/24	
Document No.		Issue date	2022/04/01	Revision	00

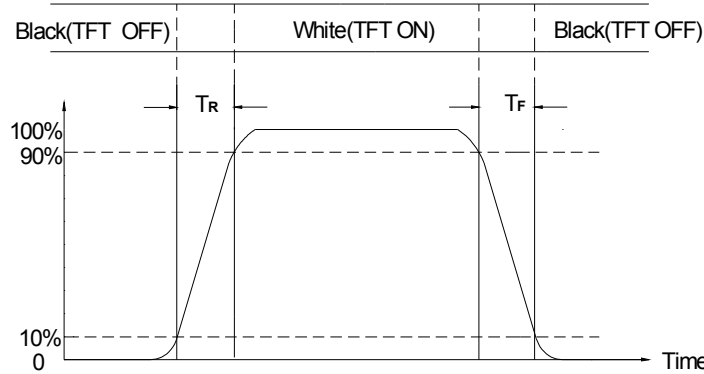

Figure 6 Definition of Response Time

Note (6) Definition of Luminance of White

Measure the luminance of White pattern (Ref.: Active Area)

Display Luminance=L1 (center point)

H—Active Area Width, V—Active Area Height, L—Luminance

Note (7) Definition of Luminance Uniformity (Ref.: Active Area)

Measure the luminance of White pattern at 9 points.

Luminance Uniformity= $\text{Min.}(L1, L2, \dots LX) / \text{Max.}(L1, L2, \dots LX)$

H—Active Area Width, V—Active Area Height, L—Luminance

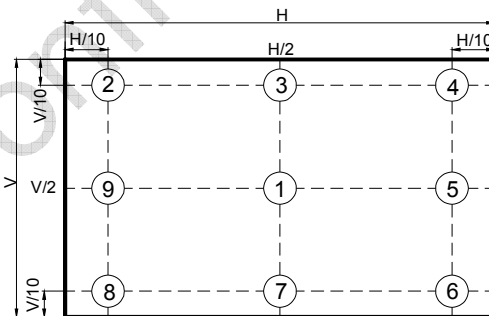

Figure 7 Measurement Locations of 9 Points

Note (8) All optical data are based on IVO given system & nominal parameter & testing machine in this document.

Document Title	M156GWFA R0 Tentative Product Specification		Page No.	10/24	
Document No.		Issue date	2022/04/01	Revision	00

4.0 Electrical Characteristics

4.1 Interface Connector

Table 3 Signal Connector Type

Item	Description
Manufacturer / Type	STM MSBKT2407P30HB
Mating Receptacle / Type (Reference)	JAE FI-X30HL(Locked Type)

Table 4 Signal Connector Pin Assignment

Pin No.	Symbol	Description	Remarks
1	RxO0-	Negative LVDS differential data input (Odd data)	-
2	RxO0+	Positive LVDS differential data input (Odd data)	-
3	RxO1-	Negative LVDS differential data input (Odd data)	-
4	RxO1+	Positive LVDS differential data input (Odd data)	-
5	RxO2-	Negative LVDS differential data input (Odd data)	-
6	RxO2+	Positive LVDS differential data input (Odd data)	-
7	GND	Ground	-
8	RxOCLK-	Negative LVDS differential clock input (Odd clock)	-
9	RxOCLK+	Positive LVDS differential clock input (Odd clock)	-
10	RxO3-	Negative LVDS differential data input (Odd data)	-
11	RxO3+	Positive LVDS differential data input (Odd data)	-
12	RxE0-	Negative LVDS differential data input (Even data)	-
13	RxE0+	Positive LVDS differential data input (Even data)	-
14	GND	Ground	-
15	RxE1-	Negative LVDS differential data input (Even data)	-
16	RxE1+	Positive LVDS differential data input (Even data)	-
17	GND	Ground	-

IVO InfoVision Optoelectronics (Kunshan) Co.,LTD.

Document Title	M156GWFA R0 Tentative Product Specification		Page No.	11/24	
Document No.		Issue date	2022/04/01	Revision	00

18	RxE2-	Negative LVDS differential data input (Even data)	-
19	RxE2+	Positive LVDS differential data input (Even data)	-
20	RxECLK-	Negative LVDS differential clock input (Even data)	-
21	RxECLK+	Positive LVDS differential clock input (Even data)	-
22	RxE3-	Negative LVDS differential data input (Even data)	-
23	RxE3+	Positive LVDS differential data input (Even data)	-
24	GND	Ground	-
25	Bist	LCD Panel Self Test Enable(3.3V Typ) For IVO use,When it is not used, Connecting to GND or Floating is recommended	-
26	SDA	I2C-Compatible Serial-Data Input For IVO Use, Floating is recommended in the Costumer	-
27	SCL	I2C-Compatible Serial-Clock Input For IVO Use, Floating is recommended in the Costumer	-
28	VDD	Power Supply Input Voltage(3.3V)	-
29	VDD	Power Supply Input Voltage(3.3V)	-
30	VDD	Power Supply Input Voltage(3.3V)	-

Table 5 LED Connector Name / Designation

Item	Description
Manufacturer / Type	STM/MSB24038P5A
Mating Receptacle / Type (Reference)	STM/P24038P5

Table 6 LED Connector Pin Assignment

Pin No.	Symbol	Description	Remarks
1	VLED	Power Supply(12V Typ)	-
2	GND	Ground	-
3	EN	LED Backlight control on/off control(3.3V Typ)	-
4	PWM	System PWM Signal Input for Dimming (3.3V Typ)	-
5	NC	NC Reserved	-

Note: The type of wire used for BL connector is AWG-28

Document Title	M156GWFA R0 Tentative Product Specification			Page No.	12/24
Document No.		Issue date	2022/04/01	Revision	00

4.2 Signal Electrical Characteristics

4.2.1 Signal Electrical Characteristics For LVDS Receiver

The built-in LVDS receiver is compatible with (ANSI/TIA/TIA-644) standard.

Table 7 LVDS Receiver Electrical Characteristics

Parameter	Symbol	Min.	Typ.	Max.	Unit	Conditions
Differential Input High Threshold	V _{th}	-	-	(+100)	mV	V _{CM} =1.2V
Differential Input Low Threshold	V _{tl}	(-100)	-	-	mV	V _{CM} =1.2V
Magnitude Differential Input Voltage	V _{ID}	(100)	-	(600)	mV	-
Common Mode Voltage	V _{CM}	(0.7)	-	(1.6)	V	-

Note (1) Input signals shall be low or Hi- resistance state when VDD is off.

Note (2) All electrical characteristics for LVDS signal are defined and shall be measured at the interface connector of LCD.

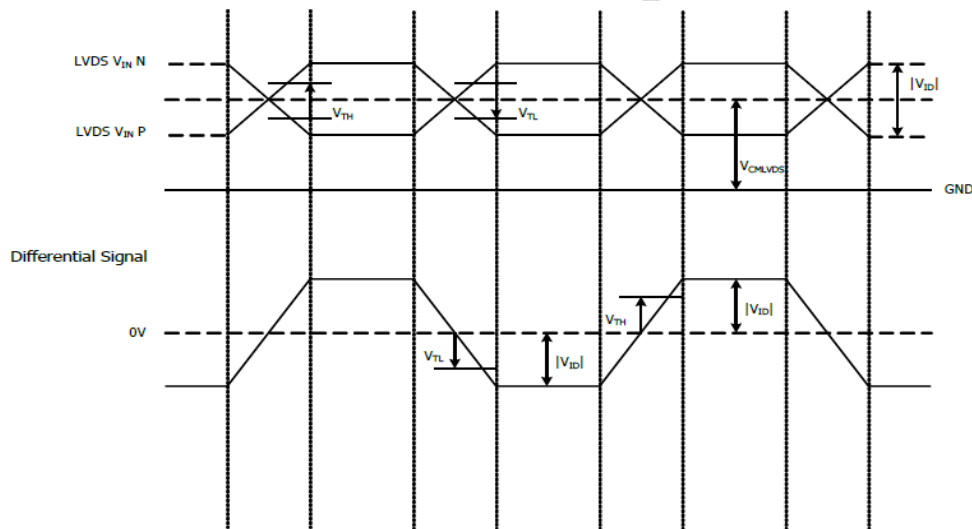

Figure 8 Voltage Definitions

Table 8 LVDS AC Electrical Characteristics

Parameter	Symbol	Min.	Typ.	Max.	Unit
Clock Period	TLVCP	-	(T)	-	ns
Clock High Time	TLVCH	-	(4T/7)	-	ns
Clock Low Time	TLVCL	-	(3T/7)	-	ns

Note: T=1/Fclk

Document Title	M156GWFA R0 Tentative Product Specification		Page No.	13/24	
Document No.		Issue date	2022/04/01	Revision	00

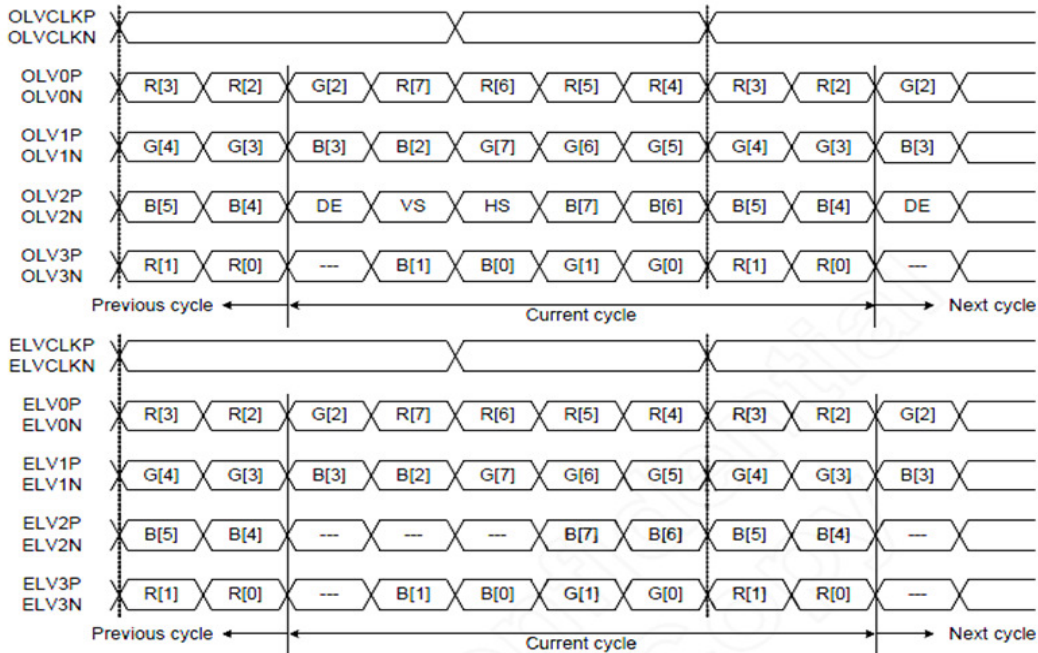

Figure 9 Data Mapping

4.2.2 LVDS Receiver Internal Circuit

Figure 11 shows the internal block diagram of the LVDS receiver. This LCD module equips termination resistors for LVDS link.

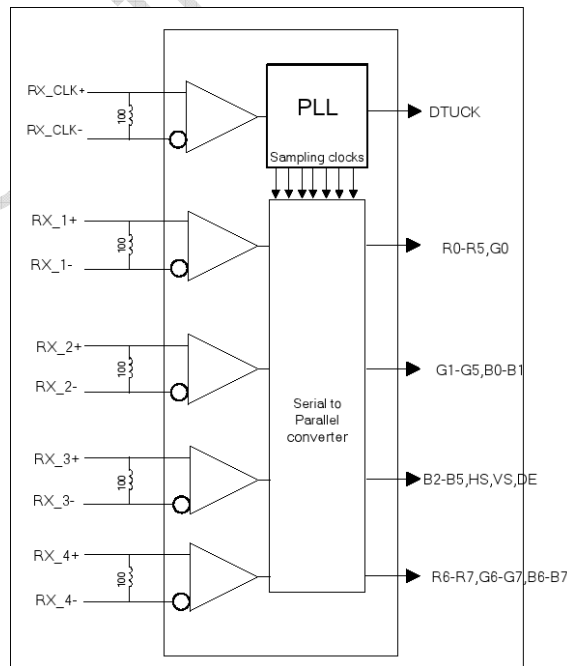

Figure 10 LVDS Receiver Internal Circuit

4.3 Interface Timings

Document Title	M156GWFA R0 Tentative Product Specification			Page No.	14/24
Document No.		Issue date	2022/04/01	Revision	00

Table 9 Interface Timings

Parameter	Symbol	Min.	Typ.	Max.	Unit
LVDS Clock Frequency	Fclk	(69.5)	(70.5)	(73)	MHz
H Total Time	HT	(1104)	(1116)	(1080+A)	Clocks
H Active Time	HA	1080			-
V Total Time	VT	(1050)	(1052)	(960+B)	Lines
V Active Time	VA	960			-
Frame Rate	FV	-	(60)	-	Hz

Note (1) SCC can only be driven to 2%

Document Title	M156GWFA R0 Tentative Product Specification			Page No.	15/24
Document No.		Issue date	2022/04/01	Revision	00

4.4 Input Power Specifications

Input power specifications are as follows.

Table 10 Input Power Specifications

Parameter	Symbol	Min.	Typ.	Max.	Unit	Note	
<i>System Power Supply</i>							
LCD Drive Voltage (Logic)	V_{DD}	(3.0)	(3.3)	(3.6)	V	(1),(2)	
VDD Current	White Pattern I_{DD}	-	-	(0.454)	A	(1),(3)	
VDD Power Consumption	White Pattern P_{DD}	-	-	(1.5)	W		
LCD Self Test (BIST)	High level voltage	V_{BIST}	(0.7*VDD)	-	(VDD)	V	(1)
	Low level voltage		(0)	-	(0.3*VDD)	V	
Rush Current	I_{Rush}	-	-	(1.5)	A	(1),(4)	
Allowable Logic/LCD Drive Ripple Voltage	V_{VDD-RP}	-	-	(200)	mV	(1),(3)	
<i>LED Power Supply</i>							
LED Input Voltage	V_{LED}	(10.8)	(12)	(13.2)	V	(1),(2),(8)	
LED Power Consumption	P_{LED}	-	-	(26.3)	W	(1),(5),(8)	
LED Forward Voltage	V_F	-	-	(3.2)	V	(1),(2)	
LED Forward Current	I_F	-	(70)	-	mA		
PWM Signal Voltage	High level voltage	V_{PWM}	(1.2)	-	(5.5)		V
	Low level voltage		(0)	-	(0.5)		
LED Enable Voltage	High level voltage	V_{LED_EN}	(1.5)	-	(5.5)	V	
	Low level voltage		(0)	-	(0.5)		
Input PWM Frequency	F_{PWM}	(100)	-	(1,000)	Hz	(1),(2),(5)	
Duty Ratio	PWM	(10)	-	(100)	%	(1),(6)	
LED Life Time	LT	(50,000)	-	-	Hours	(1),(7)	

Note (1) All of the specifications are guaranteed under normal conditions. Normal conditions are defined as follow: Temperature: 25°C, Humidity: 55± 10%RH.

Note (2) All of the absolute maximum ratings specified in the table, if exceeded, may cause faulty operation or unrecoverable damage. It is recommended to follow the typical value.

Note (3) The specified V_{DD} current and power consumption are measured under the $V_{DD} = 3.3\text{ V}$, $F_V = 60\text{ Hz}$ condition and White Pattern.

Note (4) The figures below is the measuring condition of V_{DD} . Rush current can be measured when

Document Title	M156GWFA R0 Tentative Product Specification		Page No.	16/24	
Document No.		Issue date	2022/04/01	Revision	00

T_{RUSH} is 0.5 ms.

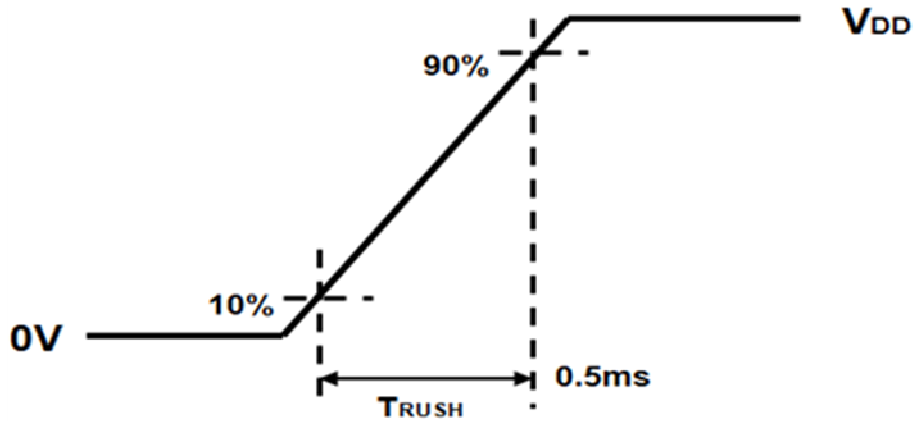

Figure 11 V_{DD} Rising Time

Note (5) The power consumption of LED Driver are under the $V_{LED} = 12.0V$, Dimming of Max luminance.

Note (6) Although acceptable range as defined, the dimming ratio is not effective at all conditions. The PWM frequency should be fixed and stable for more consistent luminance control at any specific level desired.

Note (7) The operation of LED Driver below minimum dimming ratio may cause flickering or reliability issue.

Note (8) The life time is determined as the sum of the lighting time till the luminance of LCD at the typical LED current reducing to 50% of the minimum value under normal operating condition.

Document Title	M156GWFA R0 Tentative Product Specification		Page No.	17/24	
Document No.		Issue date	2022/04/01	Revision	00

4.5 Power ON/OFF Sequence

Interface signals are also shown in the chart. Signals from any system shall be Hi- resistance state or low level when V_{DD} voltage is off.

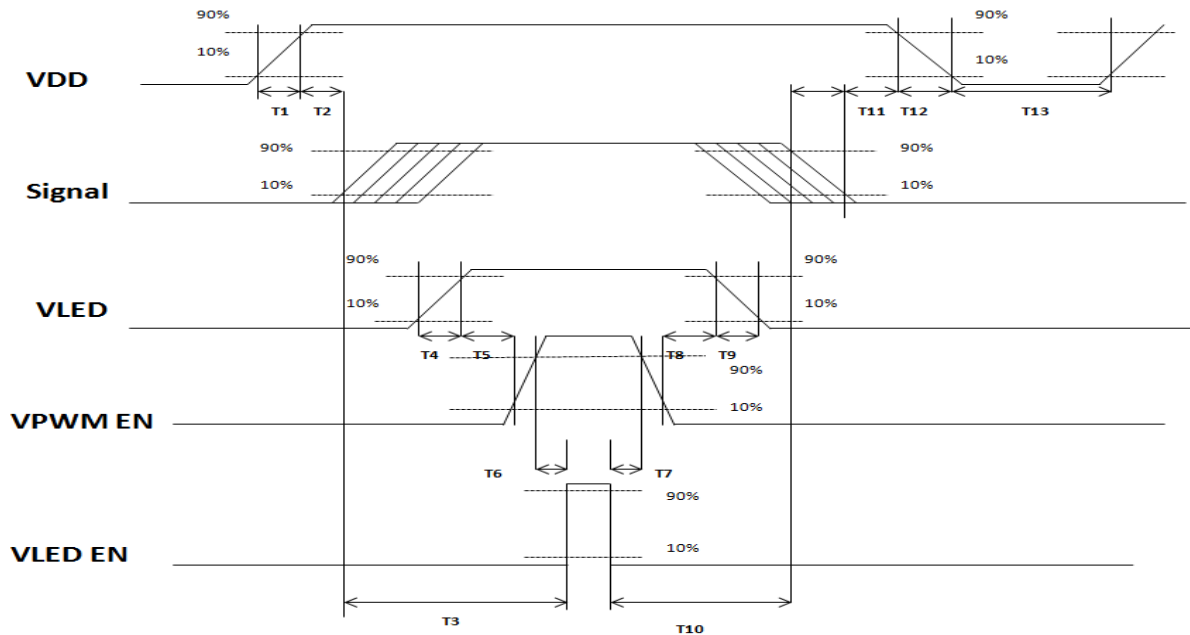

Figure 12 Power Sequence

Table 11 Power Sequencing Requirements

Parameter	Min.	Typ.	Max.	Unit
T1	(0.5)	-	(10)	ms
T2	(30)	(40)	(50)	ms
T3	(200)	-	-	ms
T4	(0.5)	-	(10)	ms
T5	(10)	-	-	ms
T6	(10)	-	-	ms
T7	(0)	-	-	ms
T8	(10)	-	-	ms
T9	-	-	(10)	ms
T10	(110)	-	-	ms
T11	(0)	(16)	(50)	ms
T12	-	-	(10)	ms
T13	(1,000)	-	-	ms

Document Title	M156GWFA R0 Tentative Product Specification		Page No.	18/24	
Document No.		Issue date	2022/04/01	Revision	00

5.0 Mechanical Characteristics

5.1 Outline Drawing

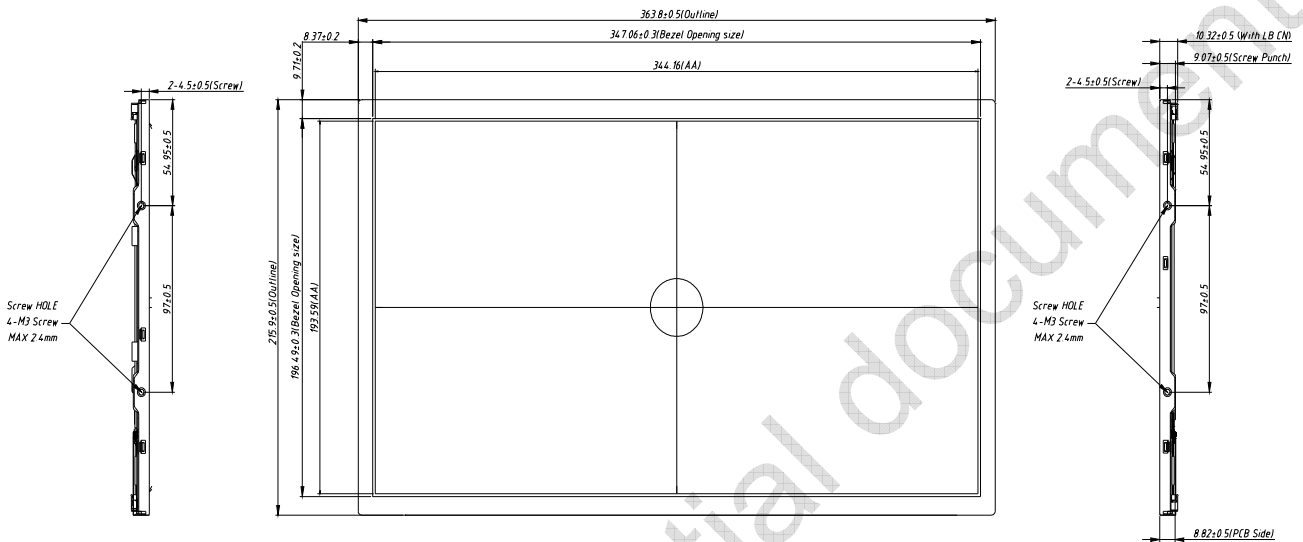
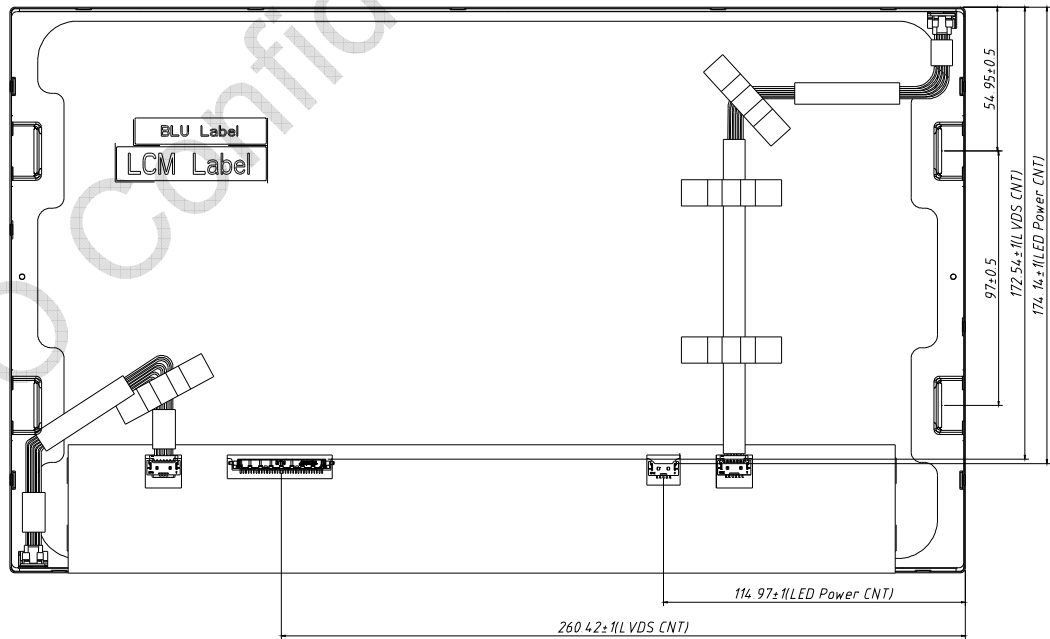

Figure 13 Reference Outline Drawing (Front Side)



Unmarked tolerance is $\pm 0.5\text{mm}$

Figure 14 Reference Outline Drawing (Back Side)

Document Title	M156GWFA R0 Tentative Product Specification			Page No.	19/24
Document No.		Issue date	2022/04/01	Revision	00

5.2 Dimension Specifications

Table 12 Module Dimension Specifications

Item	Min.	Typ.	Max.	Unit
Width	(363.3)	(363.80)	(364.3)	mm
Height	(215.4)	(215.90)	(216.4)	mm
Thickness	-	-	(9.32)	mm
Weight	-	-	(990)	g

Document Title	M156GWFA R0 Tentative Product Specification			Page No.	20/24
Document No.		Issue date	2022/04/01	Revision	00

6.0 Reliability Conditions

Table 13 Reliability Condition

Item	Package	Test Conditions	Note		
High Temperature Operating Test	Module	$T_{gs} = 85^{\circ}\text{C}$, 300hrs	(1),(2),(3),(4)		
High Temperature Storage Test	Module	$T_a = 85^{\circ}\text{C}$, 300hrs	(1),(2),(3),(4)		
Low Temperature Operating Test	Module	$T_a = -30^{\circ}\text{C}$, 300 hours	(1),(2),(3),(4)		
High Temperature/High Humidity Operating Test	Module	$T_a = 40^{\circ}\text{C}$, 90%RH, 300 hours	(1),(2),(3),(4)		
Thermal Shock Non-operation Test	Module	$-20^{\circ}\text{C} \sim 60^{\circ}\text{C}$, 1hr/each cycle , 100cycles	(1),(3),(4)		
Shock Non-operating Test	Module	100G,6ms,X Y Z×2faces×3times	(1),(3),(5)		
Vibration Non-operating Test	Module	half-sine Frequency: 8Hz ~ 33Hz Stroke: 1.3mm Sweep: 2.9G 33.3Hz ~ 400Hz X, Z Cycle: 15 minutes 2 hrs for each direction of X, Z; 4 hours for Y direction			
ESD Test	Operating	Module	Contact	$\pm 8 \text{ KV}$, 150pF(330Ohm)	(1),(2), (6)
		Air	$\pm 15 \text{ KV}$, 150pF(330Ohm)		

Note (1) A sample can only have one test. Outward appearance, image quality and optical data can only be checked at normal conditions according to the IVO document before reliable test. Only check the function of the module after reliability test.

Note (2) The setting of electrical parameters should follow the typical value before reliability test.

Note (3) During the test, it is unaccepted to have condensate water remains. Besides, protect the module from static electricity.

Note (4) The sample must be released for 24 hours under normal conditions before judging.

Furthermore, all the judgment must be made under normal conditions. Normal conditions are defined as follow: Temperature: 25°C , Humidity: $55 \pm 10\% \text{RH}$. $T_a =$ Ambient Temperature, $T_{gs} =$ Glass Surface Temperature.

Note (5) The module should be fixed firmly in order to avoid twisting and bending.

Note (6) It could be regarded as pass, when the module recovers from function fault caused by ESD after resetting.

Document Title	M156GWFA R0 Tentative Product Specification		Page No.	21/24	
Document No.		Issue date	2022/04/01	Revision	00

7.0 Package Specification

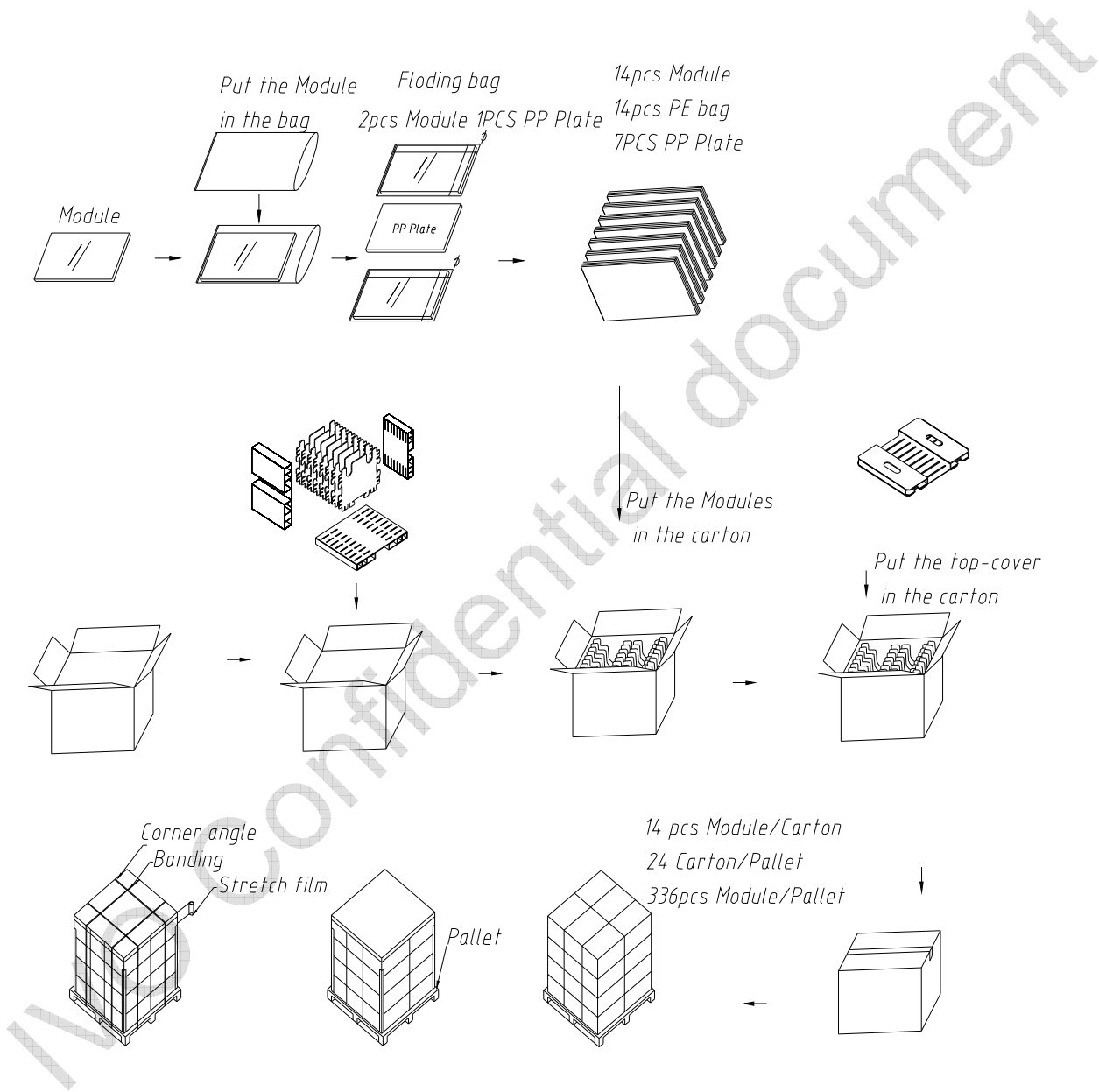

Figure 15 Packing Method

Document Title	M156GWFA R0 Tentative Product Specification		Page No.	22/24	
Document No.		Issue date	2022/04/01	Revision	00

8.0 Lot Mark

TBD

IVO Confidential document

Document Title	M156GWFA R0 Tentative Product Specification			Page No.	23/24
Document No.		Issue date	2022/04/01	Revision	00

9.0 General Precaution

9.1 Using Restriction

This product is not authorized for using in life supporting systems, aircraft navigation control systems, military systems and any other appliance where performance failure could be life-threatening or lead to be catastrophic.

9.2 Operation Precaution

(1)The LCD product should be operated under normal conditions.

Normal conditions are defined as below:

Temperature: 25°C

Humidity: 55±10%

Display pattern: continually changing pattern (Not stationary)

(2) Brightness and response time depend on the temperature. (It needs more time to reach normal brightness in low temperature.)

(3) It is necessary for you to pay attention to condensation when the ambient temperature drops suddenly. Condensate water would damage the polarizer and electrical contacted parts of the module. Besides, smear or spot will remain after condensate water evaporating.

(4) If the absolute maximum rating value was exceeded, it may damage the module.

(5) Do not adjust the variable resistor located on the module.

(6) Sufficient suppression to the electromagnetic interference shall be done by system manufacturers. Grounding and shielding may be important to minimize the interference.

(7) Image sticking may occur when the module displayed the same pattern for long time.

(8) Do not connect or disconnect the module in the “power on” condition. Power supply should always be turned on/off by the “power on/off sequence”

(9) Ultra-violet ray filter is necessary for outdoor operation.

9.3 Mounting Precaution

(1) All the operators should be electrically grounded and with Ion-blown equipment turning on when mounting or handling. Dressing finger-stalls out of the gloves is important for keeping the panel clean during the incoming inspection and the process of assembly.

(2) It is unacceptable that the material of cover case contains acetic or chloric. Besides, any other material that could generate corrosive gas or cause circuit break by electro-chemical reaction is not desirable.

(3) The case on which a module is mounted should have sufficient strength so that external force is not transmitted to the module directly.

(4) It is obvious that you should adopt radiation structure to satisfy the temperature specification.

(5) It should be attached to the system tightly by using all holes for mounting, when the module is assembled. Be careful not to apply uneven force to the module, especially to the PCB on the back.

(6) A transparent protective film needs to be attached to the surface of the module.

(7) Do not press or scratch the polarizer exposed with anything harder than HB pencil lead. In

Document Title	M156GWFA R0 Tentative Product Specification			Page No.	24/24
Document No.		Issue date	2022/04/01	Revision	00

addition, don't touch the pin exposed with bare hands directly.

(8) Clean the polarizer gently with absorbent cotton or soft cloth when it is dirty.

(9) Wipe off saliva or water droplet as soon as possible. Otherwise, it may cause deformation and fading of color.

(10) Clean the panel gently with absorbent cotton or soft cloth when it is dirty. Ethanol(C₂H₅OH) is allowed to be used. Ketone (ex. Acetone), Toluene, Ethyl acid, Methyl chloride, etc are not allowed to be used for cleaning the panel, which might react with the polarizer to cause permanent damage.

(11) Do not disassemble or modify the module. It may damage sensitive parts in the LCD module, and cause scratches or dust remains. IVO does not warrant the module, if you disassemble or modify the module.

9.4 Handling Precaution

(1) Static electricity will generate between the film and polarizer, when the protection film is peeled off. It should be peeled off slowly and carefully by operators who are electrically grounded and with Ion-blown equipment turning on. Besides, it is recommended to peel off the film from the bonding area.

(2) The protection film is attached to the polarizer with a small amount of glue. When the module with protection film attached is stored for a long time, a little glue may remain after peeling.

(3) If the liquid crystal material leaks from the panel, keep it away from the eyes and mouth. In case of contact with hands, legs or clothes, it must be clean with soap thoroughly.

9.5 Storage Precaution

When storing modules as spares for long time, the following precautions must be executed.

(1) Store them in a dark place. Do not expose to sunlight or fluorescent light. Keep the temperature between 5°C and 35°C at normal humidity.

(2) The polarizer surface should not come in contact with any other object. It is recommended that they be stored in the container in which they were shipped.

(3) It is recommended to use it in a short-time period, after it's unpacked. Otherwise, we would not guarantee the quality.

9.6 Others

When disposing LCD module, obey the local environmental regulations.